



Gas Conversion Kit Instructions

Applies to: Model UDAP, UDAS, UDBP,
and UDBS Unit Heaters

General and Warnings

All gas conversion must be done by a qualified service person in accordance with these instructions and in compliance with all codes and requirements. In Canada, gas conversion shall be carried out in accordance with the requirements of the Provincial Authorities having jurisdiction and in accordance with the requirements of the CAN/CGA-B149.1 and .2 installation code.

Hazard Intensity of Warnings in this Manual

HAZARD INTENSITY LEVELS

1. **DANGER:** Failure to comply will result in severe personal injury or death and/or property damage.
2. **WARNING:** Failure to comply could result in severe personal injury or death and/or property damage.
3. **CAUTION:** Failure to comply could result in minor personal injury and/or property damage.

WARNING

Improper installation, adjustment, alteration, service, or maintenance can cause property damage, injury, or death. Read the installation, operation and maintenance instructions thoroughly before installing or servicing this equipment.

FOR YOUR SAFETY

- **WHAT TO DO IF YOU SMELL GAS**
 - Do not try to light any appliance.
 - Do not touch any electrical switch; do not use any phone in your building.
 - Leave the building immediately.
 - Immediately call your gas supplier from a phone remote from the building. Follow the gas supplier's instructions.
 - If you cannot reach your gas supplier, call the fire department.
- Installation and service must be performed by a qualified installer, service agency, or the gas supplier.

Do not store or use gasoline or other flammable vapors and liquids in the vicinity of this or any other appliance.

WARNING

The conversion kit is to be selected and installed by a qualified service person in accordance with these instructions and in compliance with all codes and requirements of authorities having jurisdiction. Failure to follow instructions could result in death, serious injury and/or property damage. The qualified agency performing this work assumes responsibility for this conversion.

General and Warnings (cont'd)

DANGER

The gas burner in this gas-fired equipment is designed to provide safe complete combustion. However, if the installation does not permit the burner to receive the proper supply of combustion air, complete combustion may not occur. The result is incomplete combustion which produces carbon monoxide, a poisonous gas that can cause death.

Safe operation of indirect-fired gas burning equipment requires a properly operating vent system which vents all flue products to the outside atmosphere. FAILURE TO PROVIDE PROPER VENTING WILL RESULT IN A HEALTH HAZARD WHICH COULD CAUSE SERIOUS PERSONAL INJURY OR DEATH.

On separated combustion Model UDAS and UDBS heaters, install either the horizontal or vertical combustion air/vent system illustrated in the heater venting manual, using the concentric adapter supplied. For all heater installations, always comply with the combustion air requirements in the installation codes and instructions. Model UDAP and UDBP units installed in a confined space must be supplied with air for combustion as required by Code and in the heater installation manual. Combustion air at the burner should be regulated only by manufacturer-provided equipment. NEVER RESTRICT OR OTHERWISE ALTER THE SUPPLY OF COMBUSTION AIR TO ANY HEATER. MAINTAIN THE VENT OR VENT/COMBUSTION AIR SYSTEM IN STRUCTURALLY SOUND AND PROPER OPERATING CONDITION.

Application and Kit Selection

The gas conversion kits in these instructions are for Model UDAP, UDAS, UDBP, and UDBS heaters equipped with either a single-stage or two-stage gas valve. Each kit includes two or three spring kits and burner orifices for multiple sizes. See pages 7 through 10 for a list of conversion kit components. Some parts will not be used; select the parts to be used carefully.

Kit P/N's, Application, and Components

- Natural **TO** Propane Kits.....pages 7-8
- Propane **TO** Natural Kits.....page 9-10

Gas Conversion Instructions

1. Check kit contents for agreement with the parts list and the size of heater being serviced. (See the parts lists and application for each kit on pages 7-10.)

Conversion of a unit using these kits will not alter the input rate. Refer to the rating plate on the heater for input rate and other appropriate information.

(NOTE: If adjusted for high altitude operation, input rate will be affected. For high altitude input ratings and capacities, refer to **TABLE 3A** on page 11 for UDAS and UDAP or **TABLE 3B** on page 12 for Models UDBP and UDBS.)

2. Turn off the gas supply at a shutoff valve outside of the heater and turn off the electrical supply. Open the control access panel.
3. Select and Install the Regulator Spring Kit (valve conversion kit)

All kits include two or three regulator spring kits. Check the package carefully and choose the regulator spring kit that corresponds with the valve on the heater.

NOTE: The other regulator spring kit(s) will not be used.

WARNING

Regulator spring kits are not interchangeable. Each spring kit must be used only in the model and type of valve for which the kit is designated. Verify compatibility before installing the regulator spring kit.

To install the spring regulator conversion kit, follow the valve manufacturer's installation instructions that are included with the spring conversion kit. After a new regulator spring kit is installed, it is necessary to adjust the spring for the correct manifold pressure. This adjustment can only be made after the heater is in operation; instructions are included in Step No. 7.

FIGURE 1 - Gas Valve and Burner Orifice Locations (Fan model is illustrated; gas valve and orifice locations are the same on blower models.)

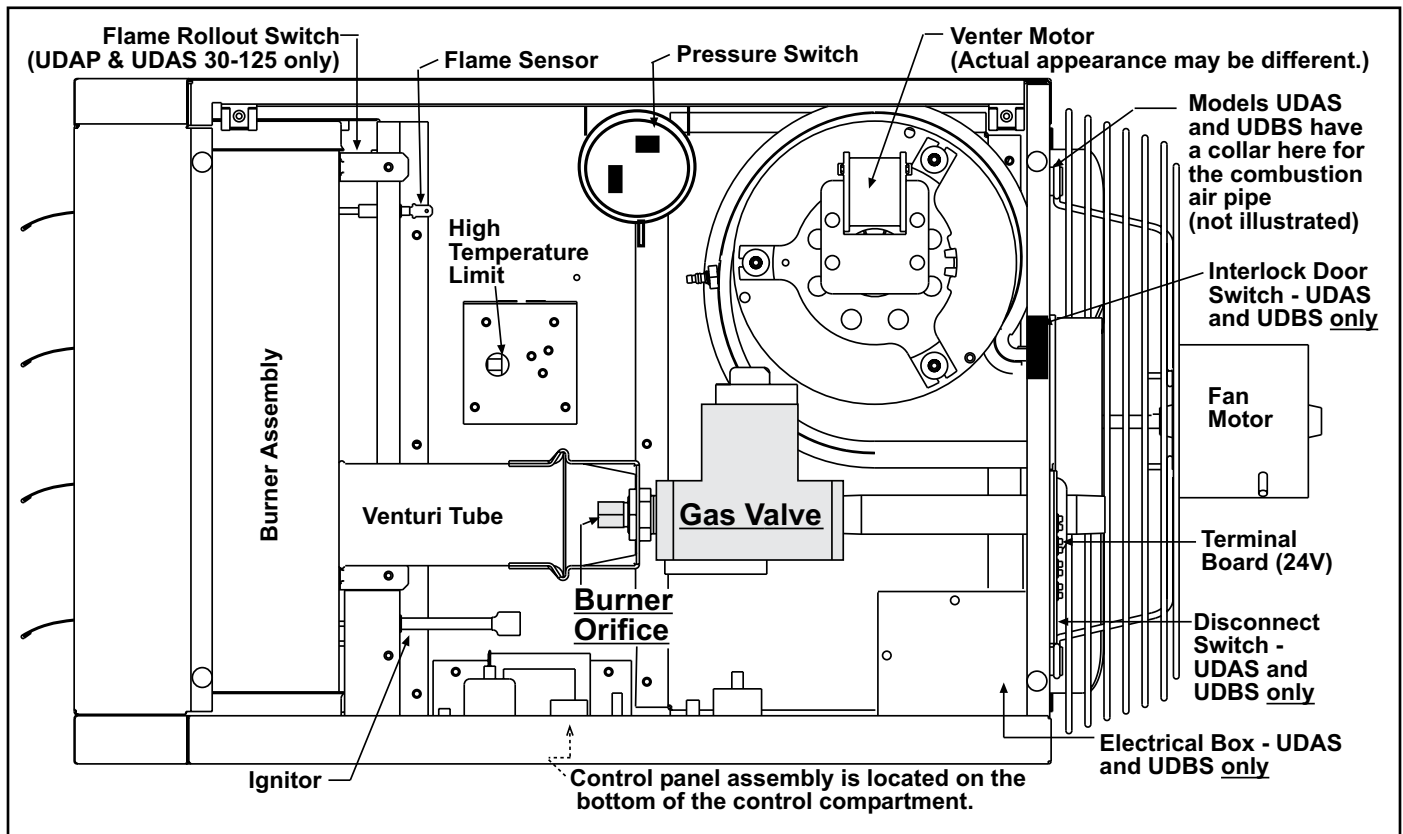

4. Select and Install the Burner Orifice - Applies to Models UDAP/UDAS/UDBP/ UDBS - All Sizes

Remove or Install the Air Restrictor Plate - Applies only to Models UDAP/ UDAS/UDBP/UDBS - Sizes 30, 45, 60, 75, 100, and 150 AND Models UDBP/ UDBS Size 125

WARNING
Do not attempt to drill orifice. Use factory-supplied orifice only.

4A) Select the orifice and Determine Air Restrictor Plate Requirement.

Because each kit is designed to convert more than one size of heater, there are two or three burner orifices per kit. From **TABLE 1** below, find the marking that is on the orifice for the size of heater being converted. From the kit, select the orifice with that marking. The other orifice(s) will not be used in this conversion.

TABLE 1 - Burner Orifice P/N's and Markings

Burner Orifice - Models UDAP, UDAS, UDBP, and UDBS									
Size		30	45	60	75	100	125		
Natural Gas	P/N	196853	196838	196839	196855	120158	196840		
	Marking	#37	#30	3.7MM	#19	#10	#4		
Propane	P/N	196844	196845	196846	196852	196854	196847		
	Marking	1.6MM	#48	2.3MM	#39	3.0MM	3.2MM		
Size		150	175	200	225	250	300	350	400
Natural Gas	P/N	131581	196891	196892	221121	208255	221122	221123	196897
	Marking	5.9MM	E	6.8MM	6.95MM	L	8.0MM	8.7MM	9.6MM
Propane	P/N	196898	196899	196900	196901	196902	196903	196904	196905
	Marking	9/64"	#24	4.1MM	11/64"	#14	#8	#3	5.8MM

Instructions (cont'd)

FIGURE 2 -

- 1) Location of the Burner Orifice on all Models and Sizes
- 2) Location of the Air Restrictor Plate on UDAP, UDAS, UDBP, and UDBS 30, 45, 60, 75, 100, and 150 and UDBP and UDBS 125 when used with Propane only

- Air restrictor plate must be added when converting models and sizes listed to propane
- Air restrictor plate must be removed when converting to natural gas.

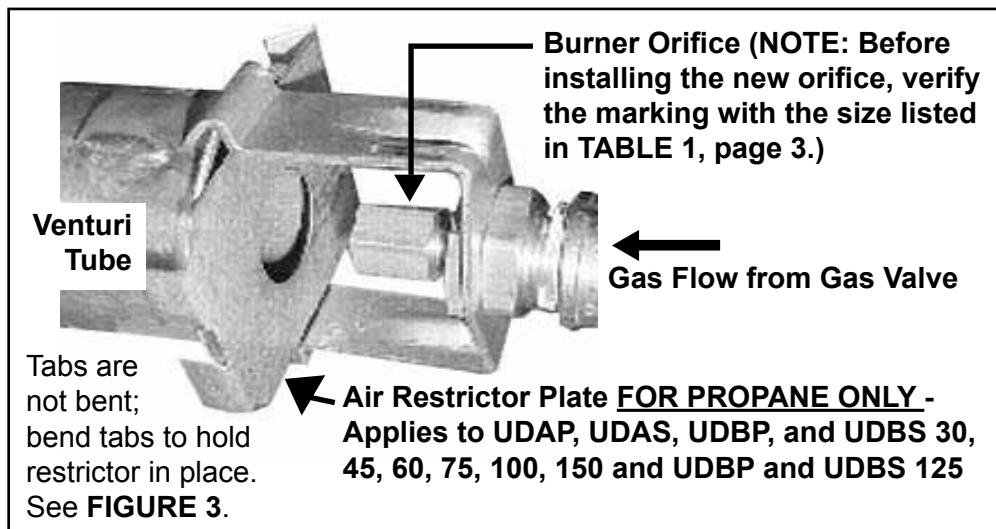

WARNING

Failure to properly install the air restrictor plate could cause property damage, personal injury, and/or death.

FIGURE 3 - Location of Holding Tabs on the Air Restrictor Plate used on UDAP, UDAS, UDBP, and UDBS 30, 45, 60, 75, 100, and 150 and UDBP and UDBS 125.

A restrictor plate is required ONLY with propane and only on the sizes listed.

To install, slide the restrictor in place so that the 45° angle is hooked over the rear of the venturi tube. On the front of the venturi tube, bend the two tabs as shown to hold the restrictor in place.
To remove, carefully unbend tabs.

Restrictor Plate Tabs

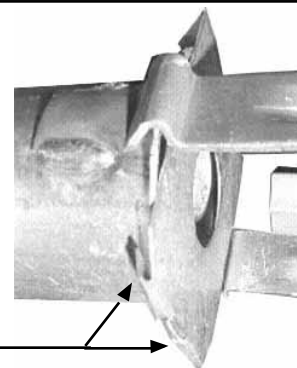

- 4B) Select and follow the instructions for type of conversion and size of heater.

Natural Gas TO Propane - Applies to Models UDAP/UDAS/UDBP/ UDBS 30, 45, 60, 75, 100, 150 and UDBP/UDBS 125.

- 1) Refer to **FIGURES 1 and 2**. Locate and carefully remove the gas orifice.
- 2) Slide the air restrictor plate over the venturi opening, positioning as illustrated in **FIGURES 2 and 3**. (**NOTE**: Verify diameter of opening with component list on page 7.)
- 3) Refer to **FIGURE 3**. Holding the air restrictor plate in position, use a pair of pliers to bend the tabs to "lock" the air restrictor plate to the venturi tube. Be sure air restrictor is aligned and secure.
- 4) Install the propane orifice selected for the heater in Step 4A, page 3.

Propane TO Natural Gas - Applies to Models UDAP/UDAS/UDBP/ UDBS 30, 45, 60, 75, 100, and 150 and UDBP/UDBS 125.

- 1) Refer to **FIGURES 1 and 2**. Locate and carefully remove the gas orifice.
- 2) Refer to **FIGURES 2 and 3** and locate the air restrictor plate on the venturi tube. Using a pair of pliers, very carefully unbend the tabs and remove the air restrictor plate.
- 3) Install the natural gas orifice selected for the heater in Step 4A, page 3.

Natural Gas TO Propane OR Propane TO Natural Gas - Applies to Models UDAP/UDAS Size 125 and UDAP/UDAS/UDBP/UDBS Sizes 175, 200, 225, 300, 350, 400

- 1) Refer to **FIGURES 1 and 2**. Locate and carefully remove the gas orifice.
- 2) Install the orifice selected for the heater in Step 4A, page 3.

NOTE: Natural gas to propane kit for UDAP/UDAS 125 and kit for UDAP/UDAS/ UDBP/UDBS Size 175 include a primary air restrictor that will not be used.

Instructions for Changing the Pressure Switch



1. In the control compartment, locate the pressure switch.
2. Mark and disconnect the two wires attached to the pressure switch.
3. Disconnect the sensing tube(s) from the pressure switch.
4. Locate the two screws holding the switch mounting bracket. Remove the screws (save screws) and the pressure switch.
5. Using the same screws, install the correct pressure switch. Attach the sensing tube(s) and wires.

TABLE 2 - Manifold Pressures by Altitude

WARNING

If the heater will be operated above 6000 ft (1830M), a high altitude pressure switch must be used.

5. Check for high altitude.

If the installation location is above 6000 ft (1830M), verify that the altitude on the rating plate or high altitude label is above 6000 ft (1830M). If the rating plate or label does not indicate an altitude above 6000 ft (1830M), order and install the appropriate high pressure switch kit.

Or, if the heater is equipped for above 6000 ft (1830M) elevation and is being installed at a lower elevation, order the appropriate switch and install it (see instructions on the left).

Contact your distributor to select the factory-authorized replacement part.

6. Turn on the electric and the gas. Relight, following the instructions on the heater. Check for gas leaks using a commercial leak detecting fluid or a rich soap and water solution. Leaks are indicated by the presence of bubbles. Check all connections. If a leak cannot be stopped by tightening, replace the part.

7. Adjust the manifold pressure. Follow requirements and instructions in 1) through 7) below to adjust manifold gas pressure.

- 1) The correct pressure adjustment depends on the area of the country in terms of elevation. If you don't know the elevation, check with your local gas company.
- 2) See **TABLE 2** and determine the required manifold pressure.

WARNING

Manifold gas pressure must never exceed 3.5" w.c. for natural gas or 10" w.c. for propane.

Manifold Pressure Settings by Altitude for the UNITED STATES					
Altitude		Natural Gas (inches w.c.)		Propane (inches w.c.)	
Feet	Meters	Single Stage and Two Stage High Fire	Two Stage Low Fire	Single Stage and Two Stage High Fire	Two Stage Low Fire
0-2000	0-610	3.5	1.8	10.0	5.0
2001-3000	611-915	3.1	1.6	8.8	4.4
3001-4000	916-1220	3.0	1.5	8.5	4.2
4001-5000	1221-1525	2.8	1.5	8.1	4.1
5001-6000	1526-1830	2.7	1.4	7.7	3.9
6001-7000	1831-2135	2.6	1.3	7.4	3.7
7001-8000	2136-2440	2.5	1.3	7.1	3.5
8001-9000	2441-2745	2.4	1.2	6.7	3.4
9001-10000	2746-3045	2.3	1.2	6.7	3.4

Manifold Pressure Settings by Altitude for CANADA					
Altitude		Natural Gas (inches w.c.)		Propane Gas (inches w.c.)	
Feet	Meters	Single Stage and Two Stage High Fire	Two Stage Low Fire	Single Stage and Two Stage High Fire	Two Stage Low Fire
0-2000	0-610	3.5	1.8	10.0	5.0
2001-4500	611-1373	2.8	1.5	8.1	4.1

- 3) See **FIGURE 4** and locate the 1/8" outlet pressure tap on the valve. Turn the knob or switch on the top of the valve to "OFF". Connect a manometer to the 1/8" pipe outlet pressure tap in the valve. Use a water column manometer that is readable to the nearest tenth of an inch. (**NOTE:** A manometer (fluid-filled gauge) is recommended rather than a spring type gauge due to the difficulty of maintaining calibration of a spring type gauge.)

FIGURE 4 - Top View of Valves identifying Pressure Taps and Adjustment Screw Location

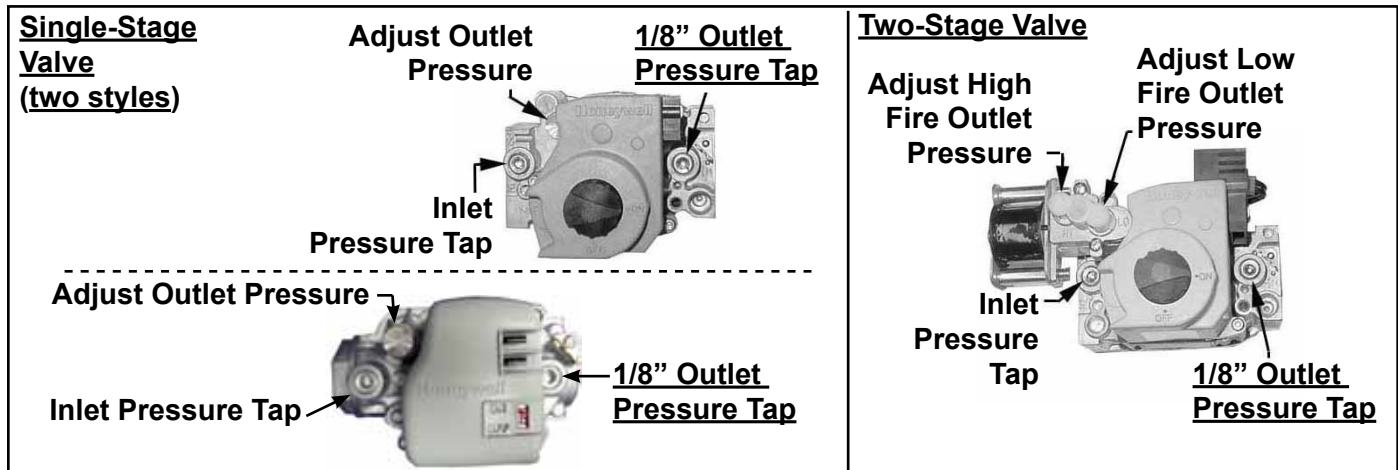

4) Measuring **Single Stage or Two Stage High Fire** - Turn the knob or switch on the top of the valve to “ON”. Remove the cap from the pressure adjusting screw and adjust the manifold pressure to the pressure selected from **TABLE 2**. Adjust pressure by turning the regulator screw IN (clockwise) to increase pressure or OUT (counterclockwise) to decrease pressure.

Measuring Two Stage Low Fire - Disconnect the wire from the “HI” terminal on the gas valve and check the low fire pressure. Turn the regulator screw to adjust the low fire outlet pressure to the “Low Fire” pressure selected from **TABLE 2**. Re-connect the wire to the gas valve.

CAUTION

DO NOT bottom out the gas valve regulator adjusting screw. This can result in unregulated manifold pressure causing excess overfire and heat exchanger failure.

- 5) Turn up the thermostat. On Models UDAS and UDBS, depress and hold the safety door switch. Cycle the burner once or twice to properly seat the adjustment spring in the valve.
Re-check the pressure(s). When the outlet pressure is right for the installation, remove the manometer and replace the cap.
Check for leakage at the pressure tap fitting.
- 6) With the heater operating, determine that the inlet pressure to the heater is between 5 and 13.5 inches w.c. for natural gas or between 10 and 13.5 inches w.c. for propane gas. Take this reading as close as possible to the heater. (The gas valves have an inlet pressure tap; see **FIGURE 4**.) If the inlet pressure is not within the specified range, the inlet pressure must be corrected and the manifold (outlet) pressure re-checked.
- 7) If the gas valve has been adjusted for operation above 2000 ft, find the High Altitude Adjustment label in the kit. Using a permanent marker, fill-in the appropriate information from **TABLE 3A**, page 11, for UDAP or UDAS or **TABLE 3B**, page 12, for UDBP or UDBS. Select a location for the label on the outside of the heater access panel so that it will be conspicuous to anyone operating or servicing the unit. Be sure the surface is clean and dry and adhere the label. (**NOTE:** At altitudes from 0-2000ft/0-610M, this label is not used.)
8. Check for safe and proper operation of the heater by observing operation for at least one complete cycle. (**NOTE:** Models UDAS and UDBS, depress and hold the safety door switch.)
9. Fill in the information required on the gas conversion tape. Select a location near the rating plate. Be sure the surface is clean and dry and affix the tape to the heater. Close the access door.

De-Coding the Heater Serial Number

The identifying model and serial number can be found on the heater rating plate. When converting fuels, it is necessary that you have the complete heater model and serial number. See the example below to determine the serial number valve code. **The rating plate identifies original equipment only so also compare the label on the gas valve with the description listed.**

Serial No. Example:	BLJ	79	6E	N	99999
	Code for Year and Month the Heater was Manufactured	Ignition Controller	Type of Valve	Type of Gas (N = Natural; L = Propane)	Consecutive Number

Natural TO Propane Conversion Kits for Models UDAP UDAS, UDBP, and UDBS

Natural TO Propane Kit, P/N 269835				
Applies to:		Models UDAP / UDAS Sizes 30 and 45		
Equipped with any of the following valves:				
Serial No. Code	Valve Manufacturer's No.			
X7 or Z3	VR8105K2942, Single-Stage, 1/2"			
Y2 or Z7	VR8205K2957, Single-Stage, 1/2"			
6E	VR8215T1239, Single-Stage, 1/2"			
Components:				
Qty	P/N	Description	Use in Valve w/ Serial No. Code	
1	98720	Spring Kit #393691 for VR8105, VR8205, VR8305 Single-Stage Valves	X7, Z3, Y2, Z7	
1	260605	Spring Kit #396221 for a VR8215 Single-Stage Valve	6E	
1	196844	SIZE 30, Burner Orifice, 1.6mm		
1	196845	SIZE 45, Burner Orifice, #48		
1	196687	Primary Air Restrictor, 1-3/8" (35mm) diameter opening		
1	64391	Conversion Tape		
1	37752	Propane Disk		
1	197062	High Altitude Adjustment Label (used above 2000ft/610M only)		

Natural TO Propane Kit, P/N 269840				
Applies to:		Models UDBP / UDBS Sizes 30 and 45		
Equipped with any of the following valves:				
Serial No. Code	Valve Manufacturer's No.			
X7 or Z3	VR8105K2942, Single-Stage, 1/2"			
Y2 or Z7	VR8205K2957, Single-Stage, 1/2"			
6E	VR8215T1239, Single-Stage, 1/2"			
Components:				
Qty	P/N	Description	Use in Valve w/ Serial No. Code	
1	98720	Spring Kit #393691 for VR8105, VR8205, VR8305 Single-Stage Valves	X7, Z3, Y2, Z7	
1	260605	Spring Kit #396221 for a VR8215 Single-Stage Valve	6E	
1	196844	SIZE 30, Burner Orifice, 1.6mm		
1	196845	SIZE 45, Burner Orifice, #48		
1	203078	Primary Air Restrictor, 1-3/16" (30mm) diameter opening		
1	64391	Conversion Tape		
1	37752	Propane Gas Disk		
1	197062	High Altitude Adjustment Label (used above 2000ft/610M only)		

Natural TO Propane Kit, P/N 269836				
Applies to:		Models UDAP / UDAS Sizes 60 and 75		
Equipped with any of the following valves:				
Serial No. Code	Valve Manufacturer's No.			
X7 or Z3	VR8105K2942, Single-Stage, 1/2"			
Y2 or Z7	VR8205K2957, Single-Stage, 1/2"			
6E	VR8215T1239, Single-Stage, 1/2"			
X8 or Z4	VR8105N2949, Two-Stage, 1/2"			
Y8 or 4A	VR8205N2921, Two-Stage, 1/2"			
Components:				
Qty	P/N	Description	Use in Valve w/ Serial No. Code	
1	98720	Spring Kit #393691 for VR8105, VR8205, VR8305 Single-Stage Valves	X7, Z3, Y2, Z7	
1	260605	Spring Kit #396221 for a VR8215 Single-Stage Valve	6E	
1	197207	Spring Kit #396021 for VR8105, VR8205, VR8305 Two-Stage Valves	X8, Z4, Y8, 4A	
1	196846	SIZE 60, Burner Orifice, 2.3mm		
1	196852	SIZE 75, Burner Orifice, #39		
1	196688	Primary Air Restrictor, 1-3/4" (44mm) diameter opening		
1	64391	Conversion Tape		
1	37752	Propane Disk		
1	197062	High Altitude Adjustment Label (used above 2000ft/610M only)		

Natural TO Propane Kit, P/N 269841				
Applies to:		Models UDBP / UDBS Sizes 60 and 75		
Equipped with any of the following valves:				
Serial No. Code	Valve Manufacturer's No.			
X7 or Z3	VR8105K2942, Single-Stage, 1/2"			
Y2 or Z7	VR8205K2957, Single-Stage, 1/2"			
6E	VR8215T1239, Single-Stage, 1/2"			
X8 or Z4	VR8105N2949, Two-Stage, 1/2"			
Y8 or 4A	VR8205N2921, Two-Stage, 1/2"			
Components:				
Qty	P/N	Description	Use in Valve w/ Serial No. Code	
1	98720	Spring Kit #393691 for VR8105, VR8205, VR8305 Single-Stage Valves	X7, Z3, Y2, Z7	
1	260605	Spring Kit #396221 for a VR8215 Single-Stage Valve	6E	
1	197207	Spring Kit #396021 for VR8105, VR8205, VR8305 Two-Stage Valves	X8, Z4, Y8, 4A	
1	196846	SIZE 60, Burner Orifice, 2.3mm		
1	196852	SIZE 75, Burner Orifice, #39		
1	202051	Primary Air Restrictor, 1-9/16" (40mm) diameter opening		
1	64391	Conversion Tape		
1	37752	Propane Disk		
1	197062	High Altitude Adjustment Label (used above 2000ft/610M only)		

Natural TO Propane Kits for Models UDAP UDAS, UDBP, and UDBS (cont'd)

For information on decoding the serial number, see page 7.

Natural TO Propane Kit, P/N 269837			
Applies to:		Models UDAP / UDAS / UDBP / UDBS Sizes 100 and 125	
Equipped with any of the following valves:			
Serial No. Code	Valve Manufacturer's No.		
Y2 or Z7	VR8205K2957, Single-Stage, 1/2"		
6E	VR8215T1239, Single-Stage, 1/2"		
Y8 or 4A	VR8205N2921, Two-Stage, 1/2"		
Components:			
Qty	P/N	Description	Use in Valve w/ Serial No. Code
1	98720	Spring Kit #393691 for VR8105, VR8205, VR8305 Single-Stage Valves	Y2, Z7
1	260605	Spring Kit #396221 for a VR8215 Single-Stage Valve	6E
1	197207	Spring Kit #396021 for VR8105, VR8205, VR8305 Two-Stage Valves	Y8, 4A
1	196854	SIZE 100, Burner Orifice, 3.0mm	
1	196847	SIZE 125, Burner Orifice, 3.2mm	
1	196688	Primary Air Restrictor, 1-3/4" (44mm) diameter opening (DO NOT use the restrictor on UDAP or UDAS Size 125.)	
1	64391	Conversion Tape	
1	37752	Propane Disk	
1	197062	High Altitude Adjustment Label (used above 2000ft/610M only)	

Natural TO Propane Kit, P/N 269838			
Applies to:		Models UDAP / UDAS / UDBP / UDBS Sizes 150 and 175	
Equipped with any of the following valves:			
Serial No. Code	Valve Manufacturer's No.		
Y2 or Z7	VR8205K2957, Single-Stage, 1/2"		
6E	VR8215T1239, Single-Stage, 1/2"		
Y8 or 4A	VR8205N2921, Two-Stage, 1/2"		
Components:			
Qty	P/N	Description	Use in Valve w/ Serial No. Code
1	98720	Spring Kit #393691 for VR8105, VR8205, VR8305 Single-Stage Valves	Y2, Z7
1	260605	Spring Kit #396221 for a VR8215 Single-Stage Valve	6E
1	197207	Spring Kit #396021 for VR8105, VR8205, VR8305 Two-Stage Valves	Y8, 4A
1	196898	SIZE 150, Burner Orifice, 9/64	
1	196899	SIZE 175, Burner Orifice, #24	
1	196688	Primary Air Restrictor, 1-3/4" (44mm) diameter opening (DO NOT use the restrictor on UDAP, UDAS, UDBP or UDBS Size 175.)	
1	64391	Conversion Tape	
1	37752	Propane Disk	
1	197062	High Altitude Adjustment Label (used above 2000ft/610M only)	

Natural TO Propane Kit, P/N 269839			
Applies to:		Models UDAP / UDAS / UDBP / UDBS Sizes 200, 225, and 250	
Equipped with any of the following valves:			
Serial No. Code	Valve Manufacturer's No.		
Y2 or Z7	VR8205K2957, Single-Stage, 1/2"		
6E	VR8215T1239, Single-Stage, 1/2"		
Y3 or Z8	VR8305K4241, Single-Stage, 3/4"		
Y8 or 4A	VR8205N2921, Two-Stage, 1/2"		
Y9 or 5A	VR8305N4297, Two-Stage, 3/4"		
Components:			
Qty	P/N	Description	Use in Valve w/ Serial No. Code
1	98720	Spring Kit #393691 for VR8105, VR8205, VR8305 Single-Stage Valves	Y2, Z7, Y3, Z8
1	260605	Spring Kit #396221 for a VR8215 Single-Stage Valve	6E
1	197207	Spring Kit #396021 for VR8105, VR8205, VR8305 Two-Stage Valves	Y8, 4A, Y9, 5A
1	196900	SIZE 200, Burner Orifice, 4.1mm	
1	196901	SIZE 225, Burner Orifice, 11/64	
1	196902	SIZE 250, Burner Orifice, #14	
1	64391	Conversion Tape	
1	37752	Propane Disk	
1	197062	High Altitude Adjustment Label (used above 2000ft/610M only)	

Natural TO Propane Kit, P/N 201732			
Applies to:		Models UDAP / UDAS / UDBP / UDBS Sizes 300, 350, and 400	
Equipped with any of the following valves:			
Serial No. Code	Valve Manufacturer's No.		
Y3 or Z8	VR8305K4241, Single-Stage, 3/4"		
Y9 or 5A	VR8305N4297, Two-Stage, 3/4"		
Components:			
Qty	P/N	Description	Use in Valve w/ Serial No. Code
1	98720	Spring Kit #393691 for VR8105, VR8205, VR8305 Single-Stage Valves	Y3, Z8
1	197207	Spring Kit #396021 for VR8105, VR8205, VR8305 Two-Stage Valves	Y9, 5A
1	196903	SIZE 300, Burner Orifice, #8	
1	196904	SIZE 350, Burner Orifice, #3	
1	196905	SIZE 400, Burner Orifice, 5.8MM	
1	64391	Conversion Tape	
1	37752	Propane Disk	
1	197062	High Altitude Adjustment Label (used above 2000ft/610M only)	

Propane TO Natural Conversion Kits for Models UDAP, UDAS, UDBP, and UDBS

For information on decoding the serial number, see page 7.

Propane TO Natural Kit, P/N 269851			
Applies to:		Models UDAP / UDAS / UDBP / UDBS	
		Sizes 30 and 45	
Equipped with any of the following valves:			
Serial No. Code	Valve Manufacturer's No.		
X9 or Z5	VR8105K2959, Single-Stage, 1/2"		
Y4 or Z9	VR8205K2965, Single-Stage, 1/2"		
9E	VR8215T5214, Single-Stage, 1/2"		
Components:			
Qty	P/N	Description	Use in Valve w/ Serial No. Code
1	98721	Spring Kit #394588 for VR8105, VR8205, VR8305 Single-Stage Valves	X9, Z5, Y4, Z9
1	261651	Spring Kit #396222 for a VR8215 Single-Stage Valve	9E
1	196853	SIZE 30, Burner Orifice, #37	
1	196838	SIZE 45, Burner Orifice, #30	
1	64391	Conversion Tape	
1	1401	Natural Gas Disk	
1	197062	High Altitude Adjustment Label (used above 2000ft/610M only)	

Propane TO Natural Kit, P/N 269852			
Applies to:		Models UDAP / UDAS / UDBP / UDBS	
		Sizes 60 and 75	
Equipped with any of the following valves:			
Serial No. Code	Valve Manufacturer's No.		
X9 or Z5	VR85K2959, Single-Stage, 1/2"		
Y4 or Z9	VR8205K2965, Single-Stage, 1/2"		
9E	VR8215T5214, Single-Stage, 1/2"		
Y1 or Z6	VR8105N2931, Two-Stage, 1/2"		
Y6 or 2A	VR8205N2913, Two-Stage, 1/2"		
Components:			
Qty	P/N	Description	Use in Valve w/ Serial No. Code
1	98721	Spring Kit #394588 for VR8105, VR8205, VR8305 Single-Stage Valves	X9, Z5, Y4, Z9
1	261651	Spring Kit #396222 for a VR8215 Single-Stage Valve	9E
1	197208	Spring Kit #396205 for VR8105, VR8205, VR8305 Two-Stage Valves	Y1, Z6, Y6, 2A
1	196839	SIZE 60, Burner Orifice, 3.7mm	
1	196855	SIZE 75, Burner Orifice, #19	
1	64391	Conversion Tape	
1	1401	Natural Gas Disk	
1	197062	High Altitude Adjustment Label (used above 2000ft/610M only)	

Propane TO Natural Kit, P/N 269853			
Applies to:		Models UDAP / UDAS / UDBP / UDBS	
		Sizes 100 and 125	
Equipped with any of the following valves:			
Serial No. Code	Valve Manufacturer's No.		
X9 or Z5	VR85K2959, Single-Stage, 1/2"		
Y4 or Z9	VR8205K2965, Single-Stage, 1/2"		
9E	VR8215T5214, Single-Stage, 1/2"		
Y1 or Z6	VR8105N2931, Two-Stage, 1/2"		
Y6 or 2A	VR8205N2913, Two-Stage, 1/2"		
Components:			
Qty	P/N	Description	Use in Valve w/ Serial No. Code
1	98721	Spring Kit #394588 for VR8105, VR8205, VR8305 Single-Stage Valves	X9, Z5, Y4, Z9
1	261651	Spring Kit #396222 for a VR8215 Single-Stage Valve	9E
1	197208	Spring Kit #396205 for VR8105, VR8205, VR8305 Two-Stage Valves	Y1, Z6, Y6, 2A
1	120158	SIZE 100, Burner Orifice, #10	
1	196840	SIZE 125, Burner Orifice, #4	
1	64391	Conversion Tape	
1	1401	Natural Gas Disk	
1	197062	High Altitude Adjustment Label (used above 2000ft/610M only)	

Propane TO Natural Kit, P/N 269854			
Applies to:		Models UDAP / UDAS / UDBP / UDBS	
		Sizes 150 and 175	
Equipped with any of the following valves:			
Serial No. Code	Valve Manufacturer's No.		
X9 or Z5	VR85K2959, Single-Stage, 1/2"		
Y4 or Z9	VR8205K2965, Single-Stage, 1/2"		
9E	VR8215T5214, Single-Stage, 1/2"		
Y1 or Z6	VR8105N2931, Two-Stage, 1/2"		
Y6 or 2A	VR8205N2913, Two-Stage, 1/2"		
Components:			
Qty	P/N	Description	Use in Valve w/ Serial No. Code
1	98721	Spring Kit #394588 for VR8105, VR8205, VR8305 Single-Stage Valves	X9, Z5, Y4, Z9
1	261651	Spring Kit #396222 for a VR8215 Single-Stage Valve	9E
1	197208	Spring Kit #396205 for VR8105, VR8205, VR8305 Two-Stage Valves	Y1, Z6, Y6, 2A
1	131581	SIZE 150, Burner Orifice, 5.9mm	
1	196891	SIZE 175, Burner Orifice, E	
1	64391	Conversion Tape	
1	1401	Natural Gas Disk	
1	197062	High Altitude Adjustment Label (used above 2000ft/610M only)	

Propane TO Natural Kits for Models UDAP, UDAS, UDBP, and UDBS (cont'd)

For information on decoding the serial number, see page 7.

Propane TO Natural Kit, P/N 269855			
Applies to:		Models UDAP / UDAS / UDBP / UDBS	
		Sizes 200, 225, and 250	
Equipped with any of the following valves:			
Serial No. Code	Valve Manufacturer's No.		
X9 or Z5	VR85K2959, Single-Stage, 1/2"		
Y4 or Z9	VR8205K2965, Single-Stage, 1/2"		
9E	VR8215T5214, Single-Stage, 1/2"		
Y5 or 1A	VR8305N4258, Single-Stage, 3/4"		
Y1 or Z6	VR8105N2931, Two-Stage, 1/2"		
Y6 or 2A	VR8205N2913, Two-Stage, 1/2"		
Y7 or 3A	VR8305N4289, Two-Stage, 3/4"		
Components:			
Qty	P/N	Description	Use in Valve w/ Serial No. Code
1	98721	Spring Kit #394588 for VR8105, VR8205, VR8305 Single-Stage Valves	X9, Z5, Y4, Z9, Y5, 1A
1	261651	Spring Kit #396222 for a VR8215 Single-Stage Valve	9E
1	197208	Spring Kit #396205 for VR8105, VR8205, VR8305 Two-Stage Valves	Y1, Z6, Y6, 2A, Y7, 3A
1	196892	SIZE 200, Burner Orifice, 6.8mm	
1	221121	SIZE 225, Burner Orifice, 6.95mm	
1	208255	SIZE 250, Burner Orifice, L	
1	64391	Conversion Tape	
1	1401	Natural Gas Disk	
1	197062	High Altitude Adjustment Label (used above 2000ft/610M only)	

Propane TO Natural Kit, P/N 201738			
Applies to:		Models UDAP / UDAS / UDBP / UDBS	
		Sizes 300, 350, and 400	
Equipped with any of the following valves:			
Serial No. Code	Valve Manufacturer's No.		
Y5 or 1A	VR8305N4258, Single-Stage, 3/4"		
Y7 or 3A	VR8305N4289, Two-Stage, 3/4"		
Components:			
Qty	P/N	Description	Use in Valve w/ Serial No. Code
1	98721	Spring Kit #394588 for VR8105, VR8205, VR8305 Single-Stage Valves	Y5, 1A
1	197208	Spring Kit #396205 for VR8105, VR8205, VR8305 Two-Stage Valves	Y7, 3A
1	221122	SIZE 300, Burner Orifice, 8.0mm	
1	221123	SIZE 350, Burner Orifice, 8.7mm	
1	196897	SIZE 400, Burner Orifice, 9.6mm	
1	64391	Conversion Tape	
1	1401	Natural Gas Disk	
1	197062	High Altitude Adjustment Label (used above 2000ft/610M only)	

**TABLE 3A -
Inputs and
Capacities
by Altitude
for Models
UDAP and
UDAS**

BTUH Inputs and Capacities by Altitude in the UNITED STATES for Model UDAP and Model UDAS													
ALTITUDE		Normal Input	Thermal Output Capacity	Minimum Input	Normal Input	Thermal Output Capacity	Minimum Input	Normal Input	Thermal Output Capacity	Minimum Input	Normal Input	Thermal Output Capacity	Minimum Input
Feet	Meters	Size 30			Size 45			Size 60			Size 75		
0-2000	0-610	30000	24600	30000	45000	37350	45000	60000	49800	42000	75000	62250	52500
2001-3000	611-915	28200	23124	28200	42300	35109	42300	56400	46812	39480	70500	58515	49350
3001-4000	916-1220	27600	22632	27600	41400	34362	41400	55200	45816	38640	69000	57270	48300
4001-5000	1221-1525	27000	22140	27000	40500	33615	40500	54000	44820	37800	67500	56025	47250
5001-6000	1526-1830	26400	21648	26400	39600	32868	39600	52800	43824	36960	66000	54780	46200
6001-7000	1831-2135	25800	21156	25800	38700	32121	38700	51600	42828	36120	64500	53535	45150
7001-8000	2136-2440	25200	20664	25200	37800	31374	37800	50400	41832	35280	63000	52290	44100
8001-9000	2441-2745	24600	20172	24600	36900	30627	36900	49200	40836	34440	61500	51045	43050
9001-10000	2746-3045	24000	19680	24000	36000	29880	36000	48000	39840	33600	60000	49800	42000
Feet	Meters	Size 100			Size 125			Size 150			Size 175		
0-2000	0-610	105000	88200	73500	120000	100800	84000	150000	124500	105000	175000	145250	122500
2001-3000	611-915	98700	82908	69090	112800	94752	78960	141000	117030	98700	164500	136535	115150
3001-4000	916-1220	96600	81144	67620	110400	92736	77280	138000	114540	96600	161000	133630	112700
4001-5000	1221-1525	94500	79380	66150	108000	90720	75600	135000	112050	94500	157500	130725	110250
5001-6000	1526-1830	92400	77616	64680	105600	88704	73920	132000	109560	92400	154000	127820	107800
6001-7000	1831-2135	90300	75852	63210	103200	86688	72240	129000	107070	90300	150500	124915	105350
7001-8000	2136-2440	88200	74088	61740	100800	84672	70560	126000	104580	88200	147000	122010	102900
8001-9000	2441-2745	86100	72324	60270	98400	82656	68880	123000	102090	86100	143500	119105	100450
9001-10000	2746-3045	84000	70560	58800	96000	80640	67200	120000	99600	84000	140000	116200	98000
Feet	Meters	Size 200			Size 225			Size 250			Size 300		
0-2000	0-610	200000	166000	140000	225000	186750	157500	250000	207500	175000	300000	249000	210000
2001-3000	611-915	188000	156040	131600	211500	175545	148050	235000	195050	164500	282000	234060	197400
3001-4000	916-1220	184000	152720	128800	207000	171810	144900	230000	190900	161000	276000	229080	193200
4001-5000	1221-1525	180000	149400	126000	202500	168075	141750	225000	186750	157500	270000	224100	189000
5001-6000	1526-1830	176000	146080	123200	198000	164340	138600	220000	182600	154000	264000	219120	184800
6001-7000	1831-2135	172000	142760	120400	193500	160605	135450	215000	178450	150500	258000	214140	180600
7001-8000	2136-2440	168000	139440	117600	189000	156870	132300	210000	174300	147000	252000	209160	176400
8001-9000	2441-2745	164000	136120	114800	184500	153135	129150	205000	170150	143500	246000	204180	172200
9001-10000	2746-3045	160000	132800	112000	180000	149400	126000	200000	166000	140000	240000	199200	168000
Feet	Meters	Size 350			Size 400								
0-2000	0-610	350000	290500	245000	400000	332000	280000						
2001-3000	611-915	329000	273070	230300	376000	312080	263200						
3001-4000	916-1220	322000	267260	225400	368000	305440	257600						
4001-5000	1221-1525	315000	261450	220500	360000	298800	252000						
5001-6000	1526-1830	308000	255640	215600	352000	292160	246400						
6001-7000	1831-2135	301000	249830	210700	344000	285520	240800						
7001-8000	2136-2440	294000	244020	205800	336000	278880	235200						
8001-9000	2441-2745	287000	238210	200900	328000	272240	229600						
9001-10000	2746-3045	280000	232400	196000	320000	265600	224000						

BTUH Inputs and Capacities by Altitude in CANADA for Models UDAP and UDAS													
ALTITUDE		Normal Input	Thermal Output Capacity	Minimum Input	Normal Input	Thermal Output Capacity	Minimum Input	Normal Input	Thermal Output Capacity	Minimum Input	Normal Input	Thermal Output Capacity	Minimum Input
Feet	Meters	Size 30			Size 45			Size 60			Size 75		
0-2000	0-610	30000	24600	30000	45000	37350	45000	60000	49800	42000	75000	62250	52500
2001-4500	611-1373	27000	22140	27000	40500	33615	40500	54000	44820	37800	67500	56025	47250
Feet	Meters	Size 100			Size 125			Size 150			Size 175		
0-2000	0-610	105000	88200	73500	120000	100800	84000	150000	124500	105000	175000	145250	122500
2001-4500	611-1373	94500	79380	66150	108000	90720	75600	135000	113400	94500	157500	132300	110250
Feet	Meters	Size 200			Size 225			Size 250			Size 300		
0-2000	0-610	200000	166000	140000	225000	186750	157500	250000	207500	175000	300000	249000	210000
2001-4500	611-1373	180000	151200	126000	202500	170100	141750	225000	189000	157500	270000	226800	189000
Feet	Meters	Size 350			Size 400								
0-2000	0-610	350000	290500	245000	400000	332000	280000						
2001-4500	611-1373	315000	264600	220500	360000	302400	252000						

**TABLE 3B -
Inputs and Capacities
by Altitude
for Models
UDBP and
UDBS**

BTUH Inputs and Capacities by Altitude in the UNITED STATES for Models UDBP and UDBS													
ALTITUDE		Normal Input	Thermal Output Capacity	Minimum Input	Normal Input	Thermal Output Capacity	Minimum Input	Normal Input	Thermal Output Capacity	Minimum Input	Normal Input	Thermal Output Capacity	Minimum Input
Feet	Meters	Size 30			Size 45			Size 60			Size 75		
0-2000	0-610	30000	24600	30000	45000	36900	45000	60000	49200	42000	75000	61500	52500
2001-3000	611-915	28200	23124	28200	42300	34686	42300	56400	46248	39480	70500	57810	49350
3001-4000	916-1220	27600	22632	27600	41400	33948	41400	55200	45264	38640	69000	56580	48300
4001-5000	1221-1525	27000	22140	27000	40500	33210	40500	54000	44280	37800	67500	55350	47250
5001-6000	1526-1830	26400	21648	26400	39600	32472	39600	52800	43296	36960	66000	54120	46200
6001-7000	1831-2135	25800	21156	25800	38700	31734	38700	51600	42312	36120	64500	52890	45150
7001-8000	2136-2440	25200	20664	25200	37800	30996	37800	50400	41328	35280	63000	51660	44100
8001-9000	2441-2745	24600	20172	24600	36900	30258	36900	49200	40344	34440	61500	50430	43050
9001-10000	2746-3045	24000	19680	24000	36000	29520	36000	48000	39360	33600	60000	49200	42000
Feet	Meters	Size 100			Size 125			Size 150			Size 175		
0-2000	0-610	105000	87150	73500	120000	99600	84000	150000	124500	105000	175000	145250	122500
2001-3000	611-915	98700	81921	69090	112800	93624	78960	141000	117030	98700	164500	136535	115150
3001-4000	916-1220	96600	80178	67620	110400	91632	77280	138000	114540	96600	161000	133630	112700
4001-5000	1221-1525	94500	78435	66150	108000	89640	75600	135000	112050	94500	157500	130725	110250
5001-6000	1526-1830	92400	76692	64680	105600	87648	73920	132000	109560	92400	154000	127820	107800
6001-7000	1831-2135	90300	74949	63210	103200	85656	72240	129000	107070	90300	150500	124915	105350
7001-8000	2136-2440	88200	73206	61740	100800	83664	70560	126000	104580	88200	147000	122010	102900
8001-9000	2441-2745	86100	71463	60270	98400	81672	68880	123000	102090	86100	143500	119105	100450
9001-10000	2746-3045	84000	69720	58800	96000	79680	67200	120000	99600	84000	140000	116200	98000
Feet	Meters	Size 200			Size 225			Size 250			Size 300		
0-2000	0-610	200000	166000	140000	225000	186750	157500	250000	207500	175000	300000	249000	210000
2001-3000	611-915	188000	156040	131600	211500	175545	148050	235000	195050	164500	282000	234060	197400
3001-4000	916-1220	184000	152720	128800	207000	171810	144900	230000	190900	161000	276000	229080	193200
4001-5000	1221-1525	180000	149400	126000	202500	168075	141750	225000	186750	157500	270000	224100	189000
5001-6000	1526-1830	176000	146080	123200	198000	164340	138600	220000	182600	154000	264000	219120	184800
6001-7000	1831-2135	172000	142760	120400	193500	160605	135450	215000	178450	150500	258000	214140	180600
7001-8000	2136-2440	168000	139440	117600	189000	156870	132300	210000	174300	147000	252000	209160	176400
8001-9000	2441-2745	164000	136120	114800	184500	153135	129150	205000	170150	143500	246000	204180	172200
9001-10000	2746-3045	160000	132800	112000	180000	149400	126000	200000	166000	140000	240000	199200	168000
Feet	Meters	Size 350			Size 400								
0-2000	0-610	350000	290500	245000	400000	328000	280000						
2001-3000	611-915	329000	273070	230300	376000	308320	263200						
3001-4000	916-1220	322000	267260	225400	368000	301760	257600						
4001-5000	1221-1525	315000	261450	220500	360000	295200	252000						
5001-6000	1526-1830	308000	255640	215600	352000	288640	246400						
6001-7000	1831-2135	301000	249830	210700	344000	282080	240800						
7001-8000	2136-2440	294000	244020	205800	336000	275520	235200						
8001-9000	2441-2745	287000	238210	200900	328000	268960	229600						
9001-10000	2746-3045	280000	232400	196000	320000	262400	224000						

BTUH Inputs and Capacities by Altitude in CANADA for Models UDBP and UDBS													
ALTITUDE		Normal Input	Thermal Output Capacity	Minimum Input	Normal Input	Thermal Output Capacity	Minimum Input	Normal Input	Thermal Output Capacity	Minimum Input	Normal Input	Thermal Output Capacity	Minimum Input
Feet	Meters	Size 30			Size 45			Size 60			Size 75		
0-2000	0-610	30000	24600	30000	45000	36900	45000	60000	49200	42000	75000	61500	52500
2001-4500	611-1373	27000	22140	27000	40500	33210	40500	54000	44280	37800	67500	55350	47250
Feet	Meters	Size 100			Size 125			Size 150			Size 175		
0-2000	0-610	105000	87150	73500	120000	99600	84000	150000	124500	105000	175000	145250	122500
2001-4500	611-1373	105001	87150.8	73501	108000	89640	75600	135000	113400	94500	157500	132300	110250
Feet	Meters	Size 200			Size 225			Size 250			Size 300		
0-2000	0-610	200000	166000	140000	225000	186750	157500	250000	207500	175000	300000	249000	210000
2001-4500	611-1373	180000	151200	126000	202500	170100	141750	225000	189000	157500	270000	226800	189000
Feet	Meters	Size 350			Size 400								
0-2000	0-610	350000	290500	245000	400000	328000	280000						
2001-4500	611-1373	315000	264600	220500	360000	295200	252000						

www.RezSpec.com; (800) 695-1901

©2012 Thomas & Betts, All rights reserved.
Trademark Notes: Reznor® is registered in at least the United States.
 All other trademarks are the property of their respective owners.
 10/12 (Serial No. Date Code BLJ) Form CP-UD-GC (Version A)

