

208414, 208415 Replacement Power Supply Kit for Electronic Air Cleaner

INSTALLATION INSTRUCTIONS

APPLICATION

These kits replace the power supplies with W8600E solid-state performance indicators (SSPI) used in the F50F and F58F Electronic Air Cleaners. See Table 1.

NOTE: The W8600E Remote Performance Indicator driver circuit board has been calibrated with the power supply in this kit. False wash indications will occur if used with a different power supply.

NOTE: Use the 120 Vac replacement power supply in Table 1 when servicing the F50F or F58F Electronic Air Cleaners that were modified with the 203365A Transformer Kit to operate at 220/240 Vac.

The power supply board in the 208414H Kit has been calibrated to provide a selectable ionizer current output. Select the correct ionizer current by moving the J6 shorting bar to the correct position. See Tables 1 and 2. See Fig. 8 for location of J6. All other kits have single-current output.

Table 1. Power Supply Replacement Guide.

EAC Model	Electrical Rating	Nominal Size		Ionizer Current		Replacement Power Supply (OS No.)
		(in.)	(mm)	(mA)	J6 Position	
F50F	120 Vac, 60 Hz	16 x 20	406 x 508	1.33	N/A	208414G
		16 x 25	406 x 635	1.65	2	208414H
		20 x 20	508 x 508	1.65	2	208414H
		20 x 25	508 x 635	2.10	3	208414H
		20 x 12-1/2	508 x 318	1.05	N/A	208414C
	220/240 Vac, 50/60 Hz	20 x 12-1/2	508 x 318	1.05	N/A	208415C
F58F	120 Vac, 60 Hz	20 x 25	508 x 635	2.10	3	208414H

INSTALLATION

When Installing this Product...

1. Read these instructions carefully. Failure to follow them could damage the product or cause a hazardous condition such as electrical shock.
2. Check the ratings given in the instructions and on the product to make sure the product is suitable for your application.
3. Installer must be a trained, experienced service technician.
4. After installation is complete, check out product operation as provided in these instructions.

WARNING

ELECTRICAL HAZARD.

Can Cause Electrical Shock or Equipment Damage.

Disconnect power before removing old power supply board and installing replacement power supply board.

To Remove Old Power Supply Board

NOTE: Observe the location of leadwires to be replaced on the power supply. Label the leadwires to identify them for reconnecting later.

- Open access door. See Fig. 1.
- Open power box.



Table 2. Ionizer Current Output Guide

J6 Shorting Bar Position	Ionizer Current Output (mA)
3	2.10
2	1.65
1	1.05

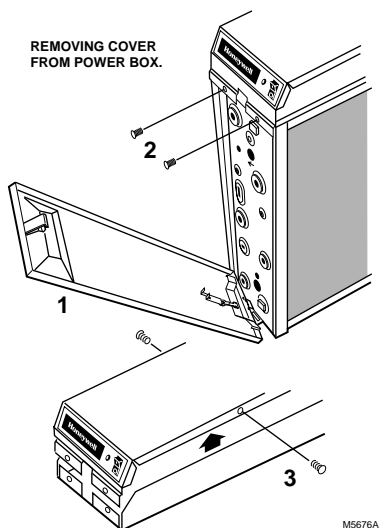

Fig. 1. Remove cover from power box.

- Disconnect the leads from 1, 2, 3, 4, P1, P2, P3, P4, P5, P12, P14, P17, P18 and P21 on the old power supply. See Fig. 2 through 5.

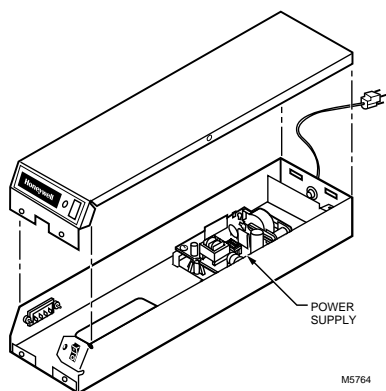

Fig. 2. Power supply location on F50F and F58F.

- Remove and discard W8600E terminal block and wiring. Set aside screws for later use.
- Remove and set aside the sheetmetal screws holding the board in place.
- Discard the old power supply.

Install New Power Supply

- When replacing the power supply, reuse the remaining leadwires in the air cleaner when removing the old power supply.
- Install W8600E terminal block and wiring supplied with this kit using screws previously removed.
- Align the mounting holes and mount the new power supply in the air cleaner, using the sheetmetal screws removed earlier. Orient the power supply so P1 and P2 are toward the front (closest to the switch and neon light).
- Route the remaining leads so the P3 and P4 leads are separate from the low voltage leads. Route all high voltage leads around, rather than over, the power supply board. Low voltage leads can go over the power supply board.
- Connect leads to the terminals on the new power supply.

IMPORTANT

Do not splice ionizer and collector leads. These leads must be unbroken to avoid electrical shock through the connector or tape covering the splice.

- Plug the electronic air cleaner directly into the correct voltage and frequency outlet or reconnect power for directly wired devices. See Fig. 3 or 4 for internal schematic. The air cleaner operates correctly at any fan speed on a multispeed or modulated speed system wired with conduit or plugged in.

NOTE: To reduce the risk of electric shock, this product has a grounding type plug with a third (grounding) pin. This plug fits only into a grounding type power outlet. If the plug does not fit into the outlet, contact a qualified electrician to install the proper outlet. Do *not* change the plug in any way.

CHECKOUT

IMPORTANT

The following instructions are for use only by qualified personnel.

With all components in place, turn on the air cleaner switch and energize the system blower. Check the following points of operation:

1. The neon light next to the on-off switch is on. If a W8600E is part of the installation, check the wall panel and make sure the ON LED is lighted. The W8600E CHECK LED comes on if there is a problem with the high voltage power supply.
2. Turn off the system blower. The neon light should go off after a few seconds. The neon light shows that the air cleaner is energized and the high voltage power supply is working properly.
3. Turn on the system blower. With the air cleaner energized, push the test button. A snapping sound indicates that the collector voltage is present on the cell. The W8600E CHECK LED comes on when the test button is held down.
4. With a multispeed blower, repeat steps 1 through 3 for each fan speed.
5. If operation is not as described, refer to the Troubleshooting and Service section.

Check Led (Air Cleaners With W8600E)

The CHECK LED on the W8600E lights to indicate the following problems: excessive dirt loading (beyond that required to activate the WASH LED), partial shorting of the collector, continuous ionizer or collector arcing, power supply failure, excessive ionizer current, or any condition causing a major reduction in high voltage.

Power Supply



WARNING ELECTRIC SHOCK HAZARD. Can Cause Personal Injury.

Always turn off power and remove access door before removing the power box or its cover.

The solid state power supply assembly has no field serviceable components. If troubleshooting indicates a power supply or solid state performance indicator problem, replace the entire power supply assembly.

Troubleshooting Procedure

The electronic air cleaner Troubleshooting chart shows how to quickly isolate an air cleaner problem. The primary diagnostic tools are the *neon light* and the *test button*. Some steps require a meter. See Fig. 7.

TROUBLESHOOTING AIR CLEANERS WITH SOLID STATE PERFORMANCE INDICATOR.

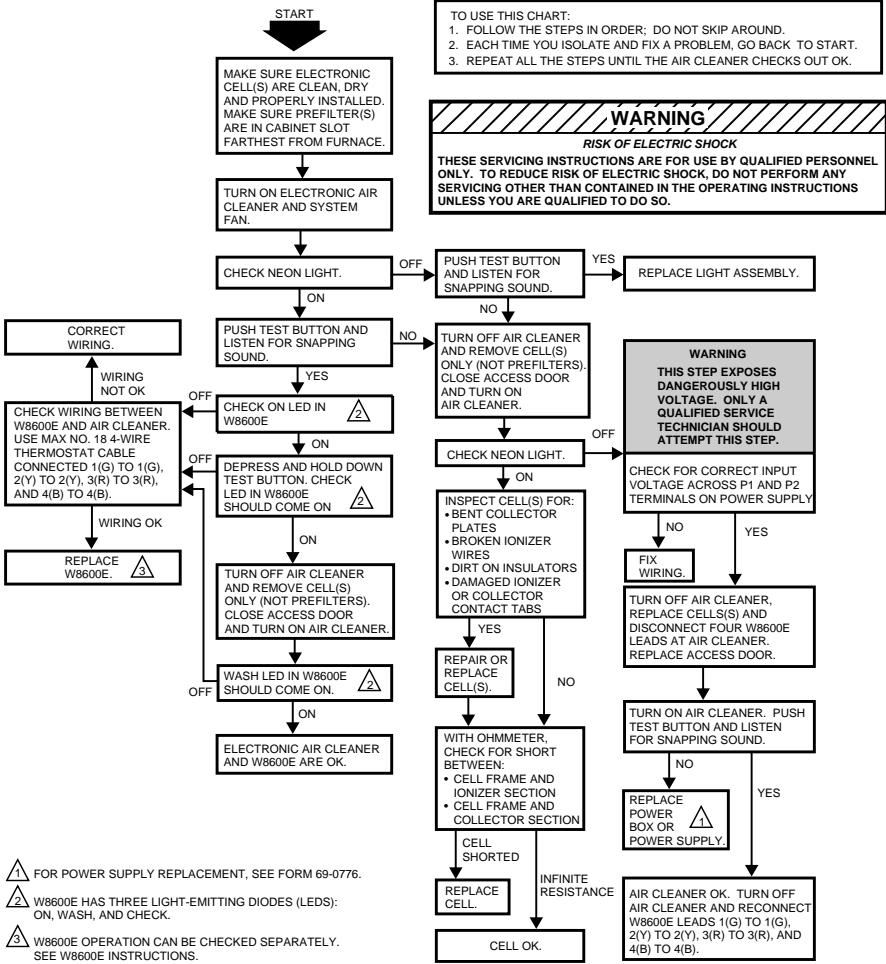

Fig. 7. Troubleshooting air cleaners with solid-state performance indicator.

Modification To Reduce Ozone Odor

⚠️ WARNING

**ELECTRIC SHOCK HAZARD.
Can Cause Personal Injury**

Always disconnect power before opening power supply cover.

The electronic air cleaner generates a small amount of ozone in normal operation. During the first or second week of operation, the amount may be higher because of sharp edges on some of the new high voltage metal parts. Normal use quickly dulls these edges.

The average person can detect the odor of ozone in concentrations as low as 0.003 to 0.010 parts per million (ppm). The electronic air cleaner contributes 0.005 to 0.010 ppm of ozone to the indoor air. The U.S. Food and Drug Administration and Health and Welfare Canada recommend that indoor ozone concentration does not exceed 0.050 ppm. As a comparison, the *outdoor* ozone level in major cities is sometimes as high as 0.100 ppm.

However, if desired, the ozone generated by the air cleaner can be reduced in one of two ways:

1. Install an activated carbon filter downstream from the air cleaner. Make sure particles from the air filter cannot fall into the air cleaner.

⚠️ WARNING

**ELECTRIC SHOCK HAZARD.
Can Cause Personal Injury.**

Only a trained service technician should perform the following procedure.

2. To reduce ozone production about 20 to 25 percent and reduce efficiency about seven to ten percent, depending on actual airflow delivered by the furnace blower:
 - a. Unplug or disconnect power supply to the air cleaner.
 - b. Open the access door.
 - c. Remove the power box cover. See Fig. 1.
 - d. Locate J5 shunting bar on the power supply. See Fig. 8. Remove the shunting bar and reinstall on only one pin.
- NOTE: The ozone will be reduced, and the shunting bar is available for reinstallation, if needed.
- e. Replace the power supply cover and access door. Turn on the power.
 - f. Repeat the checkout procedure before leaving the job.

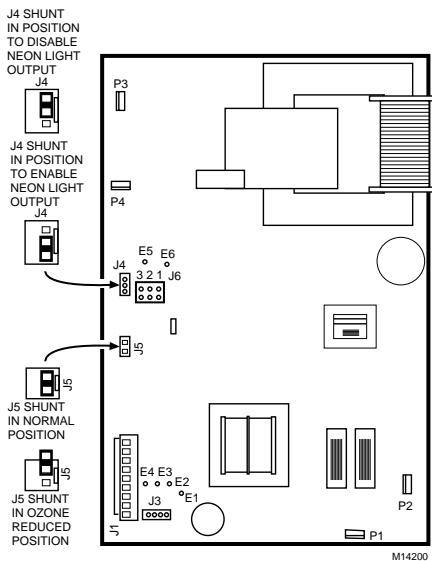

Fig. 8. Move J5 shunting bar to reduce ozone production about 20 to 25 percent.

LIMITED TWO-YEAR WARRANTY

Honeywell warrants this product to be free from defects in the workmanship or materials, under normal use and service, for a period of two (2) years from the date of purchase by the consumer. If, at any time during the warranty period, the product is defective or malfunctions, Honeywell shall repair or replace it (at Honeywell's option) within a reasonable period of time.

If the product(s) is defective, please contact:

- a) the dealer from whom you purchased it, or
- b) the local Honeywell Authorized Repair Station, or
- c) the local Honeywell Home and Building Control Office, or
- d) the Honeywell Customer Assistance Center toll free at 1-800-468-1502, or
- e) package the defective cell, power supply or other component with care, along with a bill of sale, receipt, or other dated proof of purchase, and a short description of the malfunction, and ship it, prepaid, to the following address:
Honeywell, Inc.
Return Goods Department
1050 Berkshire Lane
Plymouth, MN 55441-4437

This warranty does not cover removal or reinstallation costs. This warranty shall not apply if it is shown by Honeywell that the defect or malfunction was caused by damage that occurred while the product was in the possession of a consumer.

Honeywell sole responsibility shall be to repair or replace the product within the terms stated above. HONEYWELL SHALL NOT BE LIABLE FOR ANY LOSS OR DAMAGE OF ANY KIND, INCLUDING ANY INCIDENTAL OR CONSEQUENTIAL DAMAGES RESULTING, DIRECTLY OR INDIRECTLY, FROM ANY BREACH OF ANY WARRANTY, EXPRESS OR IMPLIED, OR ANY OTHER FAILURE OF THIS PRODUCT. Some states do not allow the exclusion or limitation of incidental or consequential damages, so this limitation may not apply to you.

THE WARRANTIES SET FORTH HEREIN ARE EXCLUSIVE, AND HONEYWELL EXPRESSLY DISCLAIMS ALL OTHER WARRANTIES, WHETHER WRITTEN, ORAL, IMPLIED OR STATUTORY, INCLUDING BUT NOT LIMITED TO ANY WARRANTIES OF MERCHANTABILITY, WORKMANSHIP, OR FITNESS FOR A PARTICULAR PURPOSE.

This warranty gives you specific legal rights, and you may have other rights which vary from state to state.

If you have any questions concerning this warranty, please write our Customer Assistance Center, Honeywell Inc., P.O. Box 524, MN27-2164, Minneapolis, Minnesota 55440-0524 or call toll-free at 1-800-468-1502, Monday-Friday, 7:00 a.m.-5:30 p.m. Central time. In Canada, Honeywell Limited/Honeywell Limitee, 155 Gordon Baker Road, North York, Ontario M2H 3N7.

Honeywell

Home and Building Control

Honeywell Inc.
Honeywell Plaza
P.O. Box 524
Minneapolis, MN 55408-0524

Home and Building Control

Honeywell Limited-Honeywell Limitée
155 Gordon Baker Road
North York, Ontario
M2H 3N7