

Installation Guide

Model 230

Wet/Wet Differential Pressure Transducer



setra



1-800-257-3872 **Toll Free**

1-978-264-0292 **Fax**

www.setra.com **Web Site**

Setra offers a complete line of products for these industries:

Industrial

HVAC

Test & Measurement

Barometric

Ultra High Purity/Sanitary

Table of Contents

1.0 GENERAL INFORMATION	1
2.0 MECHANICAL INSTALLATION	1
2.1 Media Compatibility	1
2.2 Environment	1
2.3 Pressure Fittings	1
2.4 Moisture Precautions	1
2.5 Mounting	1
2.6 Installation Procedures	2
2.7 Bleeding the Pressure Ports	2
2.8 Optional 3-Valve Manifold Assembly Procedure	3
3.0 ELECTRICAL INSTALLATION	3
3.1 Voltage Output Units	4
3.2 Current Output Units	4
4.0. CALIBRATION	4
4.1 Voltage Output Zero Adjustment	5
4.2 Voltage Output Span Adjustment	5
4.3 Current Output Zero Adjustment	5
4.4 Current Output Span Adjustment	5
5.0 RETURNING PRODUCTS FOR REPAIR.....	6
6.0 WARRANTY AND LIMITATION OF LIABILITY	6

Setra Model 230

Wet/Wet Differential Pressure Transducer

1.0 GENERAL INFORMATION

Every Model 230 has been tested and calibrated before shipment. Setra Systems 230 pressure transducers sense differential pressure and convert this difference in pressure to a proportional high level analog output. The 230 is supplied with either a 0 to 5 VDC or 0 to 10 VDC voltage output or a current output of 4 to 20 mA.

2.0 MECHANICAL INSTALLATION

2.1 Media Compatibility

Model 230 transducers are designed to be used with any gas or liquid compatible with 17-4 PH stainless steel, 300 series stainless steel and, viton/silicone or Buna-N "O"-Rings. The optional 3-valve manifold assembly is designed to be used with gases or liquids compatible with 360 Brass, Acetal plug valves and Nitrile O-rings. Never totally submerge the unit in any liquid.

2.2 Environment

The operating temperature limits of the 230 are as follows:

Operating Temperature Range °F (C°)	0 to +175 (-18 to +80)
Compensated Temperature Range °F (C°)	+30 to +150 (-1 to +65)

2.3 Pressure Fittings

Typically, standard pipe fittings and installation procedures should be used. The Model 230 has 1/4" – 18 NPT internal fittings. The high pressure port is labeled "HIGH". The optional 3-valve manifold assembly is supplied with 1/4" – 18 NPT internal fittings.

2.4 Moisture Precautions

The Model 230 is provided with a 0.875 DIA conduit opening for electrical termination, intended for a 1/2" I.D. conduit connection. This opening must be sealed according to standard industry practice, in order to prevent moisture ingress into the Model 230.

2.5 Mounting

The Model 230 is supplied with a mounting bracket and two 6-32 x 3/8 hex head screws. Attach bracket to mounting location first, using holes or band clamp notches available on large section of the bracket. Attach transducer to bracket by using the two 6-32 x 3/8 hex head screws and the two tapped holes located on the underside of the transducer.

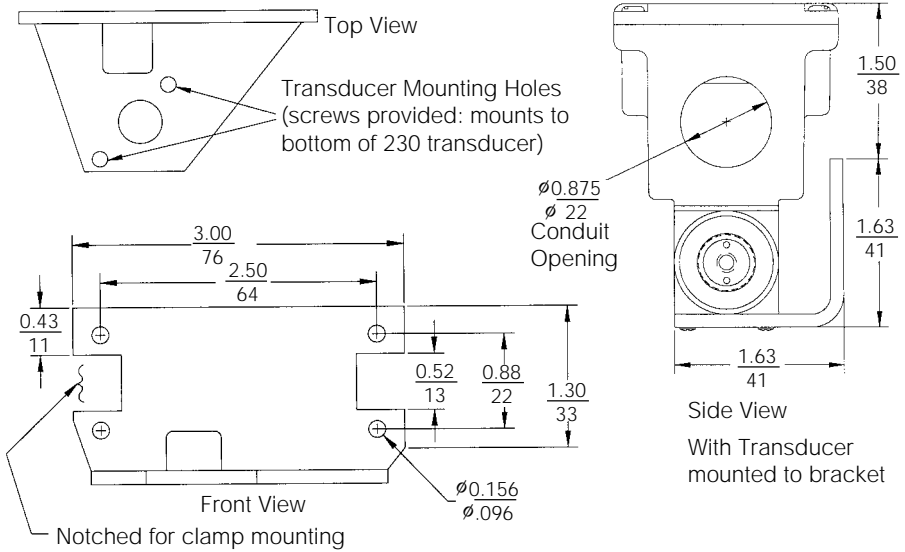

2.6 Installation Procedures

If the Model 230 is supplied with an optional 3-Valve Manifold assembly, refer to section 2.8, Optional 3-Valve Manifold Assembly Procedure, for further installation procedures. If the Model 230 is not supplied with a Setra 3-Valve manifold, the following installation procedure is recommended.

For differential pressure measurements at high line pressure (250 psig max.), it is recommended that the pressure sensor be installed with a valve in each line, plus a shunt valve across the high and low (reference) pressure ports, as shown.

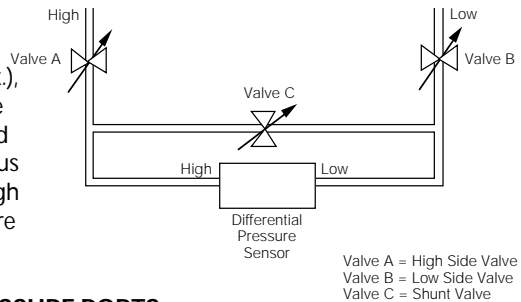

2.7 BLEEDING THE PRESSURE PORTS

3 bleed screws are on the side of the unit (2 for low pressure port, 1 for high pressure port). Install the transducer in its intended location and pressurize the ports. Back off the first bleed screw mounted on the flat side of the sensor body (2 turns max.) until liquid begins to flow out. After only bubble-free liquid flows out, retighten the bleed screw. Repeat same procedure for the second set of bleed screws located on the round section of the low pressure fitting.

Valve C should be open and Valves A and B closed whenever the system is first being wetted or pressurized. Valves A and B should then be opened slowly to avoid hammering. Valve C can then be closed and the system is operating.

When the differential pressure sensor is to be removed, Valve C must be opened first, then Valves A and B can be closed.

2.8 Optional 3-Valve Manifold Procedure

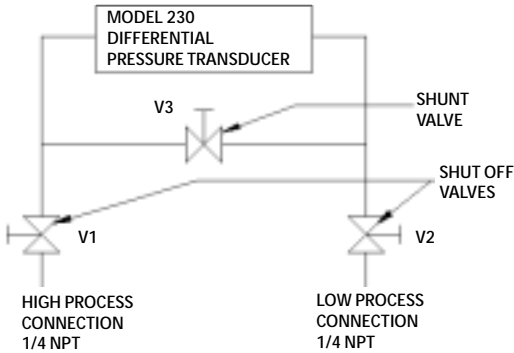

3-Valve Manifold Description

Manifold Block	Brass
Valves (3)	V1 for connection to +port V2 for connection to -port V3 for equalizing pressure
Valve type	90 Degree On/Off
Process Connections	1/4" - 18 NPT Internal Thread

The 3-Valve Manifold Assembly is normally shipped with valves V1 and V2 closed and V3 open.

To place the DPT230 into service:

1. Confirm valves V1 and V2 are closed and valve V3 is open.
2. Mount the manifold and install process connections.
3. Slowly open V2, then V1.
4. Slowly open bleed screws on the Model DPT230 (see "Bleeding the Pressure Ports" section above) to bleed the lines of air.
5. Close the bleed screws on the Model DPT230.
6. Close V3.

To take the DPT230 out of service:

1. Open V3 to equalize the pressure at the Model DPT230.
2. Close the V1 and V2.
3. Open the bleed screws on the Model DPT230.

3.0 ELECTRICAL INSTALLATION

To access electrical connections remove cover on top of Model 230.

Diagram 1

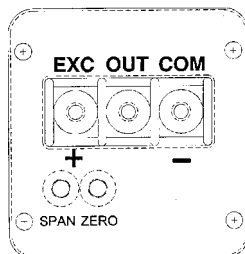

For voltage output, use COM, OUT and EXC terminals.

For current (4-20 mA) output, use + and - terminals.

3.1 Voltage Output Units

The Model 230 is a 3-wire circuit with three terminals available for wiring. The - Excitation and - Output are commoned on the circuit.

Input Power

The 230 can operate from either 9-30 VDC for 0-5 VDC output version or 13-30 VDC for 0-10 VDC output version.

Excitation	Connected to positive terminal of DC Power Supply
COM	Connect as the reference for power supply and output signal
OUT	Connect to positive terminal of Control or Pressure Monitor

3.2 Current Output Units

Model 230 (current output) transducers are true 2-wire, 4-20 mA current output devices and deliver rated current into any external load of 0-1000 ohms. The 4-20 mA current output units are designed to have current flow in one direction only. **PLEASE OBSERVE POLARITY.**

We suggest that an electrical cable shield be connected to the system's loop circuit ground to improve electrical noise rejection.

MIN Supply Voltage: $9 + .02 \times (\text{Resistance of receiver plus line})$

MAX Supply Voltage: $30 + .004 \times (\text{Resistance of receiver plus line})$

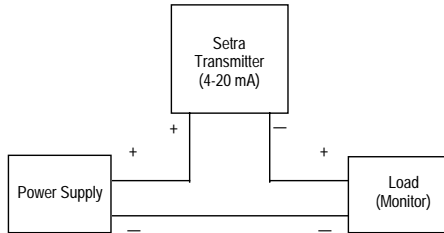

4.0 CALIBRATION

The 230 transducer is factory calibrated and should require no field adjustment. Whenever possible, any zero and/or span offsets should be corrected by software adjustment in the user's control system. However, zero and span adjustments are made by removing the cover on the top of the 230 and the 6-32 seal screws in the plastic terminal block. Be sure to reinstall seal screws after zero and/or span adjustments. Current output transducers (4-20 mA) are factory calibrated using a 250 ohm load at 24 VDC. Zero and span adjustments are approximately 300 mV (for voltage units) and ± 1.0 mA (for current units), individually.

The 230 Series is calibrated with the diaphragm in the vertical position (pressure ports horizontal). For use in other orientations, position the unit and adjust the zero by following the calibration procedure in the previous section.

Optimal results will be achieved by using the factory calibrated position. The 230 position effect is as follows (pressure ports in vertical plane): $\pm 2\%$ per g for $\pm 5D$, $\pm 1D$, $1D$, $2D$ ranges. $\pm 1\%$ per g for all other standard ranges. There is a negative output shift with the high pressure port facing up and a positive shift in the output with the high pressure port facing down.

4.1 Voltage Output Zero Adjustment

While monitoring the voltage between the positive output (OUT) and common, and with both pressure ports open to atmosphere, the zero may be adjusted. For unidirectional pressure ranges, turn the zero adjustment screw until a reading of 0.05 VDC (± 25 mV for 0-5 VDC output or ± 50 mV for 0-10 VDC output) is achieved. For bidirectional pressure ranges, set zero to 2.550 VDC (± 25 mV) for 0-5 VDC output or 5.050 VDC (± 50 mV) for 0-10 VDC output.

4.2 Voltage Output Span Adjustment

(Complete the zero adjustment before setting span.)

Span or full scale output adjustments should only be performed by using an accurate pressure standard (electronic manometer, digital pressure gage, etc.), with at least comparable accuracy to the 230 series ($\pm 0.25\%$ full scale). With full range pressure applied to the high pressure port (reference port open to atmosphere), adjust output to 5.050 VDC (± 25 mV) or 10.050 VDC (± 50 mV).

Example 1: Unidirectional pressure range of 0 to 1 PSI
Apply 1 PSI, adjust output to 5.050 VDC (or 10.050 VDC)

Example 2: Bidirectional pressure range of $\pm .5$ PSI
Apply .5 PSI, adjust output to 5.050 VDC (or 10.050 VDC)

4.3 Current Output Zero Adjustment

While monitoring the current output, and with both pressure ports open to atmosphere, the zero may be adjusted. For unidirectional pressure ranges, turn the zero adjustment screw until a reading of 4 mA (± 0.08 mA) is achieved. For bidirectional ranges, set zero to 12 mA (± 0.08 mA).

4.4 Current Output Span Adjustment

Span or full scale output adjustments should only be performed by using an accurate pressure standard (electronic manometer, digital pressure gage, etc.), with at least comparable accuracy to the 230 series ($\pm 0.25\%$ full scale). With full range pressure applied to the high pressure port (reference port open to atmosphere), adjust span to achieve 20 mA (± 0.08 mA) output.

Example 1: Unidirectional pressure range of 0 to 1 PSI
Apply 1 PSI, adjust output to 20 mA

Example 2: Bidirectional pressure range of $\pm .5$ PSI
Apply .5 PSI, adjust output to 20 mA

5.0 RETURNING PRODUCTS FOR REPAIR

Please contact a Setra Systems application engineer (1-800-257-3872, 1-978-263-1400) before returning unit for repair to review information relative to your application. Many times only minor field adjustments may be necessary. When returning a product to Setra Systems, the material should be carefully packaged and shipped prepaid to:

Setra Systems, Inc.
159 Swanson Road
Boxborough, MA 01719-1304
Attn: Repair Department

To assure prompt handling, please supply the following information and include it inside the package or returned material:

1. Name and phone number of person to contact.
2. Shipping and billing instructions.
3. Full description of the malfunction.
4. Identify any hazardous material used with product.

Notes: Please remove any pressure fittings and plumbing that you have installed and enclose any required mating electrical connectors and wiring diagrams.

Allow approximately 3 weeks after receipt at Setra Systems for the repair and return of the unit. Non-warranty repairs will not be made without customer approval and a purchase order to cover repair charges.

Calibration Services

Setra maintains a complete calibration facility that is traceable to the National Institute of Standards & Technology (NIST). If you would like to recalibrate or recertify your Setra pressure transducers or transmitters, please call our Repair Department at 800-257-3872 (978-263-1400) for scheduling.

6.0 WARRANTY AND LIMITATION OF LIABILITY

SETRA warrants its products to be free from defects in materials and workmanship, subject to the following terms and conditions: Without charge, SETRA will repair or replace products found to be defective in materials or workmanship within the warranty period; provided that:

- a) the product has not been subjected to abuse, neglect, accident, incorrect wiring not our own, improper installation or servicing, or use in violation of instructions furnished by SETRA;
- b) the product has not been repaired or altered by anyone except SETRA or its authorized service agencies;
- c) the serial number or date code has not been removed, defaced, or otherwise changed; and
- d) examination discloses, in the judgment of SETRA, the defect in materials or workmanship developed under normal installation, use and service;
- e) SETRA is notified in advance of and the product is returned to SETRA transportation prepaid.

Unless otherwise specified in a manual or warranty card, or agreed to in writing and signed by a SETRA officer, SETRA pressure and acceleration products shall be warranted for one year from date of sale.

The foregoing warranty is in lieu of all warranties, express, implied or statutory, including but not limited to, any implied warranty of merchantability for a particular purpose.

SETRA's liability for breach of warranty is limited to repair or replacement, or if the goods cannot be repaired or replaced, to a refund of the purchase price. SETRA's liability for all other breaches is limited to a refund of the purchase price. In no instance shall SETRA be liable for incidental or consequential damages arising from a breach of warranty, or from the use or installation of its products.

No representative or person is authorized to give any warranty other than as set out above or to assume for SETRA any other liability in connection with the sale of its products.

SS2010 Rev F 01/17/01

159 Swanson Road, Boxborough, MA 01719-1304
Tel: 800-257-3872/978-263-1400

setra