

Econo-Therm

INDUSTRIAL THERMOMETERS



4352 shown

- ▶ 5 1/2" Scale Size
- ▶ ± 1 Scale Division Accuracy
- ▶ Cast Aluminum Case
- ▶ Rigid Straight or Rigid 90° Angle Case

The Trerice **Econo Thermometer** provides accuracy and durability at an economical price. This liquid-in-glass thermometer has a durable cast aluminum case and a polycarbonate frame front and window. Rigid straight and rigid 90° angle cases are available.

- Optional features available: Please consult the Options & Accessories Section for details.
- Trerice Econo Thermometers (air-duct stem excluded) have no external mounting hardware, and as such, require the use of a thermowell, which is attached to the stem via a set screw. The thermowell must be ordered separately – please refer to page 153 of the Thermowell Section.

Specifications

Models	Scale Size
4350	5 1/2" Rigid Straight
4352	5 1/2" Rigid 90° Angle
Fill Type	Spirit: Blue colored, organic
Case	Cast aluminum, blue epoxy finish
Stem	Aluminum, brass or air-duct style
Connection	Use of thermowell required (must be ordered separately) Air-duct stem has mounting flange with 3 bolt holes
Window	Polycarbonate frame front
Tube	Lens front, magnifying type
Scale	Aluminum, white background with black graduations and markings
Accuracy	±1 scale division
Approximate Shipping Weight	0.5 lbs [0.23 kg]

HOW TO ORDER

Sample Order Number: **4350 1 02 07**

Model	Stem (Material)	Stem (Length)	Specific Range
4350 Straight	1 Aluminum*	02 2" (Aluminum Stem only)	See Standard Ranges
4352 90° Angle	2 Brass	04 4" (Brass Stem only)	
	9 Air-Duct **	06 6" (Air-Duct Stem)	
		12 12" (Air-Duct Stem)	

*Use of thermowell required (must be ordered separately-refer to page 153).

**Model 4352 only

Econo-Therm

All dimensions are nominal.
Dimensions in [] are in millimeters.

INDUSTRIAL THERMOMETERS

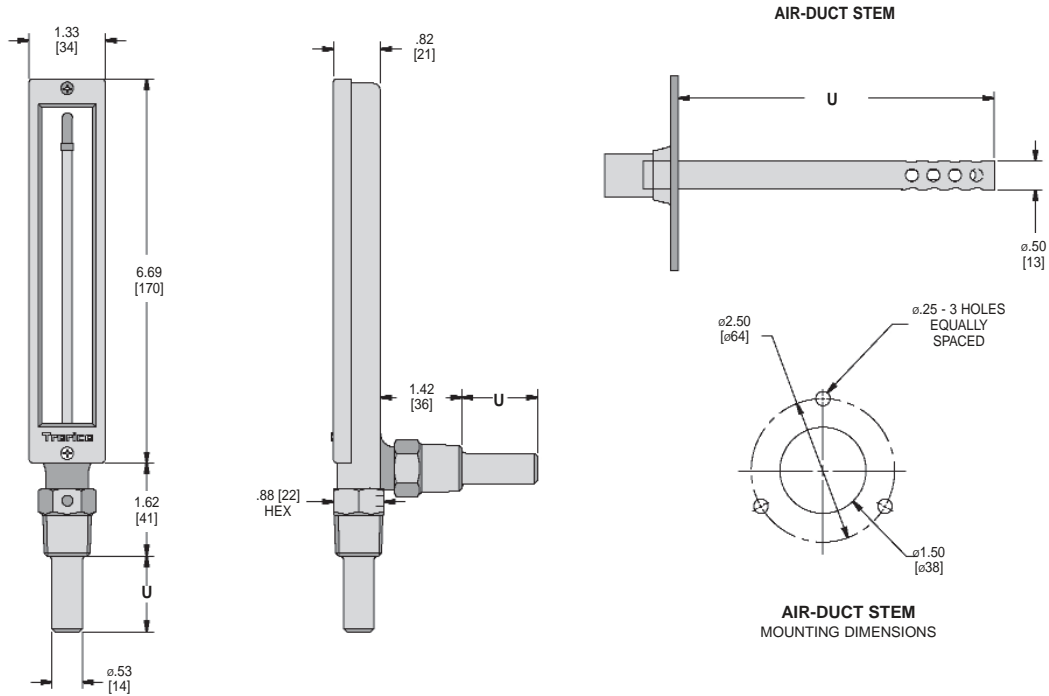

Note: Shown with required thermowell (must be ordered separately. Refer to page 153.)

U Length	Dimension
2" (Aluminum)	1.31 [33.3]
4" (Brass)	3.25 [82.6]
6" (Air-Duct)	6.00 [152.4]
12" (Air-Duct)	12.00 [304.8]

Standard Ranges

Fahrenheit Scale		Celsius Scale		Dual Scale		Fahrenheit		Celsius	
Range Code	Range	Range Code	Range	Range Code	Range	Figure Intervals	Minor Divisions	Figure Intervals	Minor Divisions
01	-40° to 110°F	17	-40° to 40°C	41	-40° to 110°F & -40° to 40°C	20°	2°	10°	1°
03	30° to 130°F	25	0° to 55°C	43	30° to 130°F & 0° to 55°C	10°	1°	5°	1°
06	30° to 180°F	27	0° to 83°C	46	30° to 180°F & 0° to 83°C	20°	2°	10°	1°
07	30° to 240°F	19	0° to 115°C	47	30° to 240°F & 0° to 115°C	20°	2°	10°	1°
08	30° to 300°F	20	0° to 150°C	48	30° to 300°F & 0° to 150°C	30°	5°	10°	2°
09	50° to 400°F	28	10° to 205°C	49	50° to 400°F & 10° to 205°C	50°	5°	20°	2°
13	200° to 500°F	32	93° to 260°C	53	200° to 500°F & 93° to 260°C	25°	5°	10°	2°

Dual scale figure intervals may differ.