

RL 147 POSITIONING RELAY

DESCRIPTION

The RL 147 Positioning Relay is a compact pneumatic device designed to provide positive positioning of a pneumatic valve or damper actuator. The positioner provides supply air pressure against the actuator diaphragm to initiate stem or shaft movement. The actuator spring reverses the stem or shaft movement.

FEATURES

- Rapid response
- Good repeatability
- Adjustable start point pressure
- Adjustable span
- Low air consumption

SPECIFICATIONS

Operating:

Ambient Temperature Range
 Storage..... -20 to 160°F (-29 to 71°C)
 Operation35 to 160°F (2 to 71°C)
 Maximum Pilot Signal Pressure30 psig (207 kPa)
 Maximum Supply Air Pressure60 psig (413 kPa)
 Start Point Adjustment Range..... 3-10 psig (21-69 kPa)
 Operating Span Adjustment Range..... 3-12 psig (21-83 kPa)
 Response 1/10 psi Input change (0.7 kPa)
 Air Capacity @ ΔP = 2 psi (14 kPa) 410 scim (112ml/s)
 Air Consumption..... 40 scim (11 ml/s)

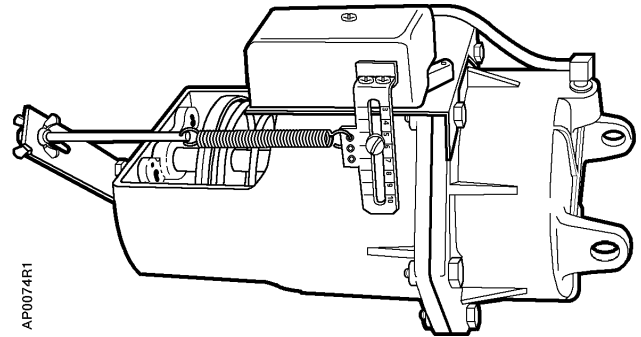

Figure 1. The RL 147 Positioning Relay mounted on a No. 6 Damper Actuator.

PRODUCT NUMBERS

Refer to Table 1.

SPECIFICATIONS, Continued

Physical:

Air Connections 1/8" (3.2 mm) NPT
 Body Materials Zinc
 Cover..... Electro Plated Steel
 DimensionsFigure 14
 Shipping Weight w/Kit..... 2 lb. (0.9 Kg)

Table 1. Product Numbers for Positioning Relay and Mounting Kits.

| Description of Actuator Type | Order Numbers | | Reference |
|--|---|--------------|-----------|
| | Positioning Relay | Mounting Kit | Page |
| No. 3 Damper Actuator For actuators manufactured after 1/1/93 | 147-2000 | 147-104 | 7 |
| No. 4 Damper Actuator | 147-2000 | 147-314 | 7 |
| No. 6 Damper Actuator | 147-2000 | 147-276 | 8 |
| 8" Valve Actuator For Flowrite actuators manufactured after 3/1/96 | 599-00426 Contains both relay and mounting kit | | 9 |
| For Model 3 Flowrite actuators manufactured between 3/1/93 and 1/1/96 | 147-2000 | 147-333 | 8 |
| For Models 1 and 2 Flowrite actuators. Also order spring arm # 147-307 for use with VF 591 5" and 6" balanced valves | 147-2000 | 147-277 | 10 |
| 12" Valve Actuator For Flowrite actuators manufactured after 1/1/96 | 599-00423 Contains both relay and mounting kit | | 9 |
| For Flowrite actuators manufactured between 3/78 and 1/1/96 | 147-2000 | 147-311 | 11 |
| For Super Flowrite and 12" Flowrite actuators manufactured before 3/78 | 147-2000 | 147-279 | 10 |

APPLICATION

The Positioning Relay is recommended for damper actuator and valve applications where rapid speed of response and/or repeatability of stem position is needed to obtain good system operation. It can be used to reduce the span of controlled devices to permit sequencing. It can also be used to increase the close-off force of a normally open actuator without affecting its spring span. This happens because the positioner uses full supply air pressure to position the actuator.

The spring range of the actuator does not effect the operation of the positioner. Therefore, it is recommended that an actuator with a high spring range, such as 8 to 13 psig (55 to 90 kPa), be selected. This combination has the high return force of the actuator spring plus the high forward force available from the positioner.

A positioning relay can be connected to handle up to four identical No. 6 damper actuators or up to six identical No. 4 damper actuators provided the following conditions are met. All actuators must operate the same damper, and no more than 100 feet of 1/4" (6.4 mm) O.D. tube is used to connect them. Remember all actuators connected this way must be identical (i.e., same size, spring range, stroke, etc.).

The positioning relay is single acting and is primarily intended for use on actuators with an integral spring to return the actuator shaft to the normal position. Applications with a double acting (spring-less) actuator require a reversing relay to provide the additional control signal.

OPERATION

A rise in thermostat pressure will unbalance the lever assembly. Refer to Figure 2. The shaft movement, through the spring arm, increases tension on the feedback spring to bring the lever assembly again into balance. A drop in thermostat pressure will unbalance the lever assembly in the opposite direction to exhaust air from the actuator until a new balance position is reached.

The positioning relay start point is adjustable. The start point adjustment nut shown in Figure 2 is used to set the start point pressure. The span adjustment screw tab location on the feedback arm and the feedback spring location on the spring guide determine the span setting of the relay.

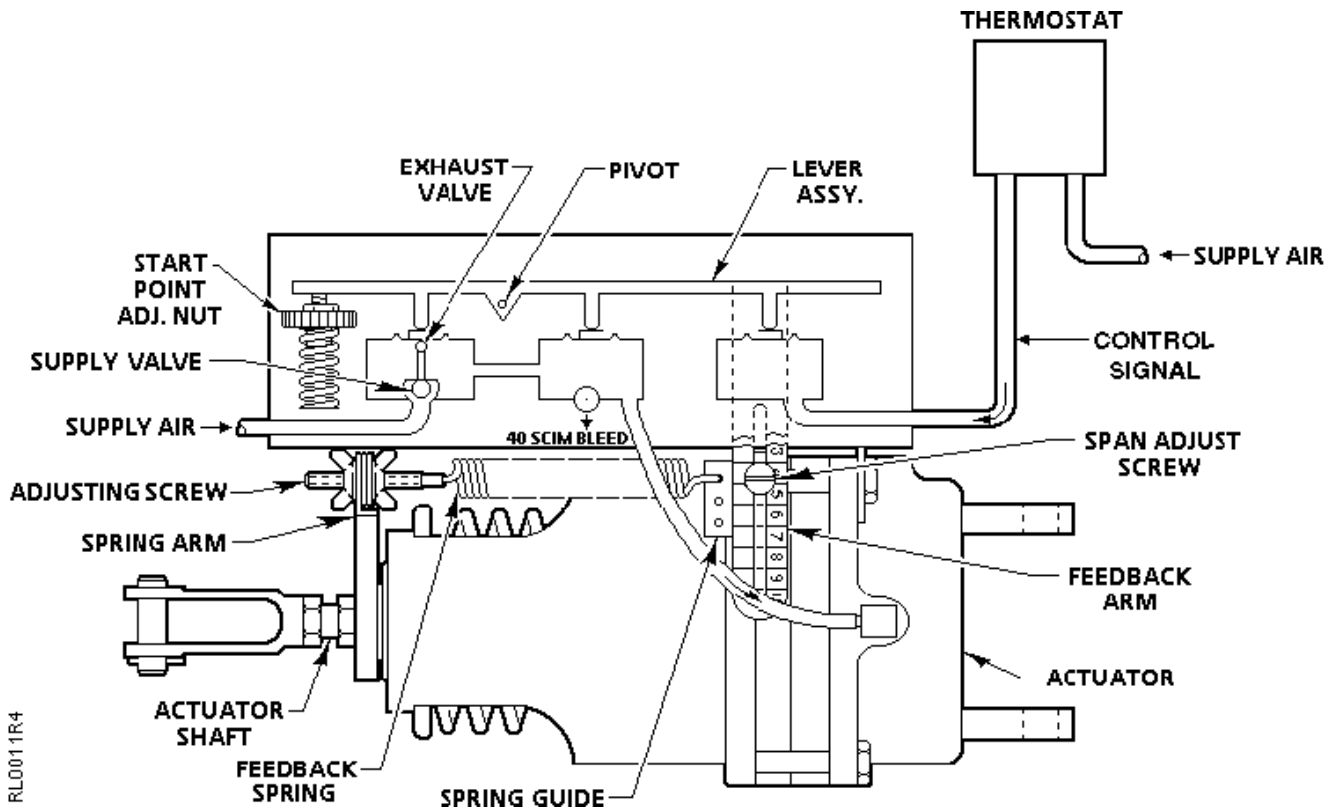

Figure 2. Operation Schematic.

RL0011R4

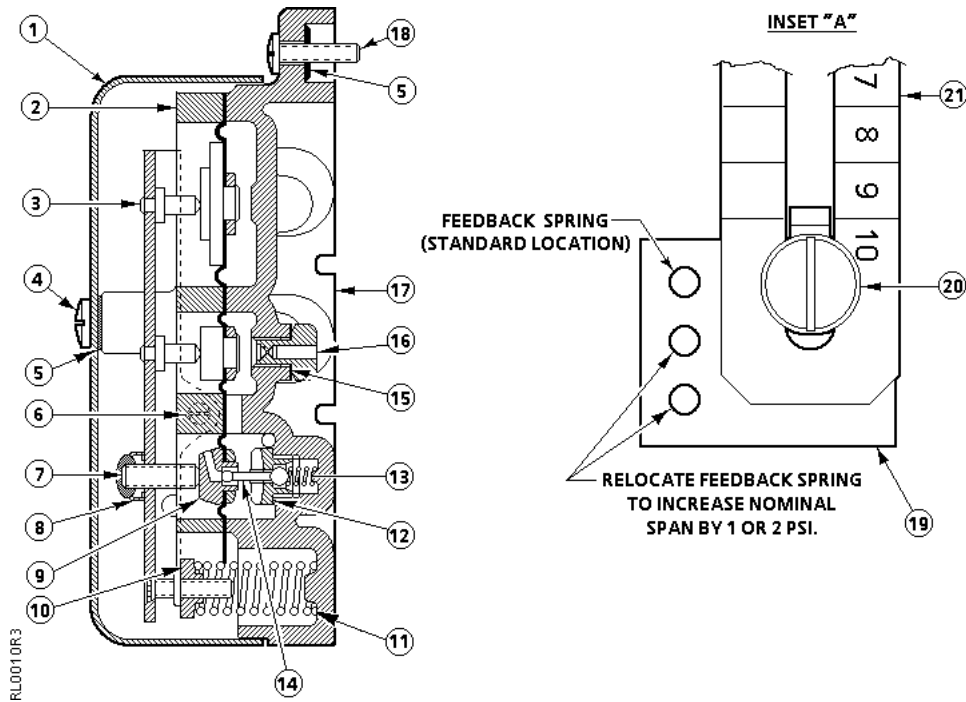

Figure 3. Construction of the RL 147 Positioning Relay.

| Item | Replacement Part No. | Description | No. Req'd | Material |
|------|----------------------|--------------------------------------|-----------|-------------------|
| 1 | 147-255 | Cover | 1 | Steel |
| 2 | — | Plate | 1 | Zamac Die Casting |
| 3 | — | Lever Assembly | 1 | |
| 4 | — | #8-32 Cover Screw | 1 | Steel |
| 5 | — | Washer | 1 | Rubber |
| 6 | 147-273 | Pivot Screw | 2 | Stainless Steel |
| 7 | — | #8-32 x 1/2 " Lg. Dual Pt. Set Screw | 1 | Steel |
| 8 | — | #8-32 Palnut | 1 | Steel |
| 9 | — | Diaphragm Assembly | 1 | |
| 10 | — | Start Point Adjustment Nut | 1 | Brass |
| 11 | — | Start Spring | 1 | Music Wire |
| 12 | — | Supply Valve Seat | 1 | Brass |
| 13 | — | Supply Valve Spring | 1 | Phosphor Bronze |
| 14 | — | Ball Assembly | 1 | Stainless Steel |
| 15 | — | Gasket | 1 | Fairprene |
| 16 | — | Bleed Port | 1 | Brass |
| 17 | — | Base | 1 | Zamac Die Casting |
| 18 | 034-048 | #6-32 x 5/8" Lg. Bind Hd Screw | 2 | Brass |
| 19 | 147-297 | Spring Guide | 1 | Steel |
| 20 | 034-067K | Span Adjustment Screw | 1 | Steel |
| 21 | — | Feedback Arm | 1 | Steel |

CALIBRATION

Complete calibration instructions are included with each positioning relay.

1. Check that you have the correct feedback spring(s) attached.
2. Identify the desired operating span and the start point pressure.

NOTE: In some cases, the actuator stem travel or stroke is not identical to the nominal value of the relay feedback spring. Refer to **Calculating the Span Setting** on page 5 to determine the span setting on the feedback arm.

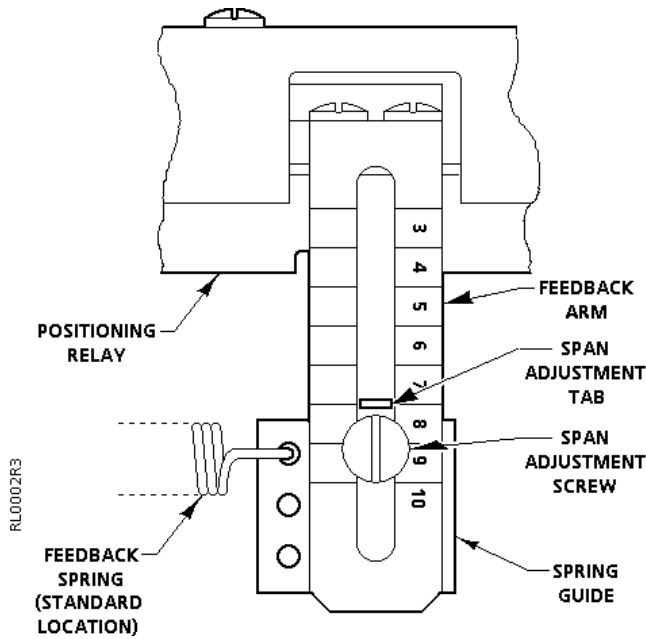

Figure 4. Span Adjustment.
 Shown at Span Setting 8.

Setting the Span. Refer to Figure 4.

The positioning relay operating span can be set for spans of 3 psig through 12 psig (21 kPa to 83 kPa).

For spans of 3 psig through 10 psig (21 to 69 kPa)

1. Check that the feedback spring is attached to the spring guide in the hole across from the span adjustment screw. This is identified as the standard location in Figure 4.
2. With a screwdriver, loosen the span adjustment screw. Move the spring guide on the feedback arm until the span adjustment tab is at the desired span setting reference number.

NOTE: The line to the left of the number is the setting.

3. Tighten the span adjustment screw.
4. The feedback spring must be parallel to the actuator shaft or valve stem. Use open end wrenches to loosen the hex nuts holding the spring arm in position on the shaft or stem. Align the feedback spring and tighten the hex nuts.
5. The feedback spring should have no slack or no stretch in it. Adjust the wing nuts and adjustment nut, if necessary

For spans of 11 psig or 12 psig (76 or 83 kPa)

1. Move the span adjustment tab to the 10 setting on the feedback arm. Follow steps 2 and 3 above.
2. Move the feedback spring one hole away from the standard location for a span of 11 psig (76 kPa) and two holes away from the standard spring location for a 12 psig (83 kPa) span. Refer to Figure 4.
3. Follow steps 4 and 5 above.

Adjusting the Start Point. Refer to Figure 6.

The positioning relay can be adjusted to start actuator movement at pressures between 3 and 10 psig (21 and 69 kPa).

1. Remove the relay cover.
2. Attach tubing with a pressure gauge and squeeze bulb to the "T" port. Supply air should be attached to the "S" port. The "M" port should be attached to the connector on the actuator.
3. Using the squeeze bulb, apply pressure to the relay. Watch the valve stem or actuator shaft to see when it begins to move. Check your pressure gauge; this is your start point pressure.
4. If this is not the desired start point pressure, turn the start point adjustment nut (Figure 5) clockwise to increase the start point pressure and counterclockwise to decrease the pressure.
5. Repeat steps 3 and 4 until the stem or shaft begins to move at the desired pressure.

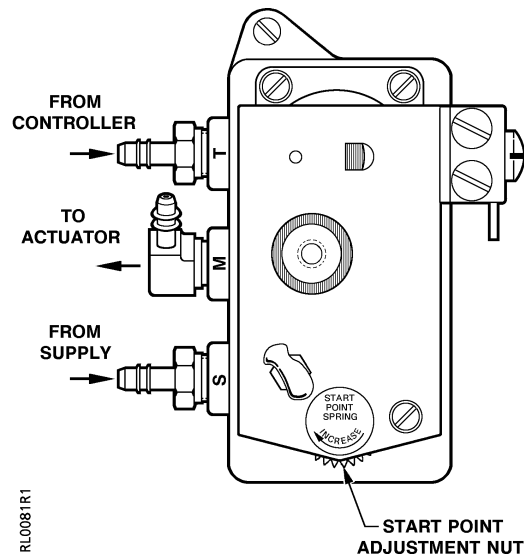

Figure 5. Start Point Adjustment.

Adjusting the Span

1. Using the squeeze bulb, apply pressure to the relay. Note the pressure at which the stem or shaft begins to move.
2. Continue to apply pressure until the stem or shaft completes its full stroke. Note the pressure.
3. The difference between the two pressures is the span.
4. If the span is not the desired span, move the spring guide to a higher reference number to increase the span or lower number to decrease the span. Refer to Figure 4.
5. Repeat steps 1 through 4 until you get the desired span.

6. If you have moved the spring guide, you will need to adjust the spring arm so that the spring is parallel to the stem or shaft.
7. Check the feedback spring. There should be no slack or no stretch in it. Adjust the wing nuts and adjustment nut, if necessary.
8. Fasten the relay cover. Fill in the information on the calibration label.

Calculating the Span Setting

1. Identify the valve stem from Table 2 or 4. If the stroke of the No. 6 damper actuator has been changed from the factory setting refer to Table 7.
2. If your stem travel matches the nominal spring travel listed in Table 2 there is no need to calculate a new span setting.
3. If your stem travel does not match the nominal spring travel listed in Table 2, choose the spring(s) whose maximum allowable travel is equal or greater than your actual stem travel.
4. Calculate the span setting with the formula below.

Formula for Span Setting

$$\text{Span Setting} = \text{Desired span} \times \frac{\text{Nominal spring travel}}{\text{Actuator stroke}}$$

Example:

Determine the span setting for a valve having desired span of 5 psig and 5/16" stroke.

Select a spring with a maximum allowable range equal to or larger than the stroke. Use the 1/4" spring with a 3/8" maximum allowable travel range. Refer to Table 2.

$$\text{Span Setting} = 5 \times \frac{0.25}{0.312} = 4$$

Set the span adjustment tab to line 4 on the feed back arm to provide a 5 psig span for this valve.

Table 2. Spring Selection.

| Spring Travel Range | | Recommended Springs | |
|---------------------|------------------------|----------------------|-------------------------------------|
| Nominal in. (mm) | Max. Allowable in (mm) | Part No. | Size & Color |
| 5/32 (5.0) | 1/4 (6.4) | 147-298 | Small Green |
| 1/4 (6.4) | 3/8 (9.5) | 147-289 | Small Cadmium Plate |
| 3/8 (9.5) | 1/2 (13) | (2)147-298 | Small Green |
| 3/4 (19) | 1 (25) | 147-290 | Small Red |
| 1 (25) | 1-1/4 (32) | 147-291 | Long Green |
| 1-1/4 (32) | 1-5/8 (41) | 147-289 plus 147-291 | Small Cadmium Plate plus Long Green |
| 1-1/2 (38) | 2 (51) | (2) 147-290 | Small Red |
| 1-3/4 (44) | 2-1/4 (57) | 147-290 plus 147-291 | Small Red plus Long Green |
| 2 (51) | 2-1/2 (64) | (2) 147-291 | Long Green |
| 2-3/8 (60) | N/A | 147-105 | 2" Red |
| 3 (76) | 3-1/4(83) | 147-292 | Long Cadmium Plate |
| 3-3/4 (95) | 4 (102) | 147-301 | 3" Red |
| 4 (102) | 4-1/4 (108) | 147-293 | Blue |
| 4 (102) | 6 (152) | 147-313 | Zinc Pl. or Yell. Chr. |
| 7 (178) | 12-1/4 (311) | 147-330 | Zinc Plate |

Table 3. Stem Travel for VP 591 Bronze Body Valves.

| Line Size in. (mm) | Stem Travel inches (mm) | | |
|-----------------------|-------------------------|----------------------------------|------------|
| | Single Seat | Double Seat | WM |
| 1/2 (13) | 3/8 (9.5) | — | 1/8 (3.2) |
| 3/4 (19) | 3/4 (19) | — | 3/16 (4.8) |
| 1 (25) | 3/4 (19) | 3/16 (4.8) | 1/4 (6.4) |
| 1-1/4 (32) | 1 (25) | 1/4 (6.4) | 5/16 (7.9) |
| 1-1/2 (38) | 1 (25) | 1/4 (6.4) | 5/16 (7.9) |
| 2 (51) | 5/8 (16) | 3/8 (9.5) NO. 5/16 (7.9) N.C. | 5/16 (7.9) |

Table 4. Stem Travel listed by 591 or 593 Flowrite Valve Product Number.

| Flowrite Product Number | Stem Travel in. (mm) |
|-------------------------|----------------------|
| 591-6480 | 5/8 (16) |
| 591-6490 | 3/4 (19) |
| 591-6540 | 5/8 (16) |
| 591-6600 | 1/8 (3.2) |
| 591-6610 | 3/16 (4.8) |
| 591-6620 | 1/4 (6.4) |
| 591-6630 | 5/16 ((7.9) |
| 591-6640 | 5/16 ((7.9) |
| 591-6650 | 5/16 ((7.9) |
| 591-6720 | 5/8 (16) |
| 591-6730 | 3/4 (19) |
| 591-6740 | 1 (25) |
| 591-6840 | 3/8 (9.5) |
| 591-6850 | 9/16 (14) |
| 591-6860 | 9/16 (14) |
| 591-6870 | 5/16 ((7.9) |
| 591-6880 | 9/16 (14) |
| 591-6890 | 9/16 (14) |
| 591-6900 | 1/4 (6.4) |
| 591-6910 | 1/4 (6.4) |
| 591-6920 | 5/16 (7.9) |
| 591-6930 | 9/16 (14) |
| 591-6940 | 3/16 (4.8) |
| 591-6950 | 1/4 (6.4) |
| 591-6960 | 1/4 (6.4) |
| 591-6970 | 3/8 (9.5) |
| 591-6980 | 3/16 (4.8) |
| 591-6990 | 1/4 (6.4) |
| 591-7000 | 1/4 (6.4) |
| 591-7010 | 5/16 ((7.9) |
| 591-7020 | 3/16 (4.8) |
| 591-7030 | 1/4 (6.4) |
| 591-7040 | 1/4 (6.4) |
| 591-7050 | 3/8 (9.5) |
| 591-7060 | 3/8 (9.5) |
| 591-7070 | 9/16 (14) |
| 591-7080 | 9/16 (14) |
| 591-7090 | 3/16 (4.8) |
| 591-7100 | 5/16 ((7.9) |
| 591-7110 | 9/16 (14) |
| 591-7870 | 3/4 (19) |

| Flowrite Product Number | Stem Travel in. (mm) |
|-------------------------|----------------------|
| 591-7871 | 3/4 (19) |
| 591-7872 | 1 (25) |
| 591-7873 | 1 (25) |
| 591-7874 | 1 (25) |
| 591-7875 | 3/4 (19) |
| 591-7876 | 3/4 (19) |
| 591-7877 | 1 (25) |
| 591-7878 | 1 (25) |
| 591-7879 | 1 (25) |
| 591-7971 | 3/8 (9.5) |
| 591-7972 | 3/4 (19) |
| 591-7973 | 3/4 (19) |
| 591-7974 | 1 (25) |
| 591-7975 | 1 (25) |
| 591-7976 | 1 (25) |
| 591-7977 | 3/8 (9.5) |
| 591-7978 | 3/4 (19) |
| 591-7979 | 3/4 (19) |
| 591-7980 | 1 (25) |
| 591-7981 | 1 (25) |
| 591-7982 | 1 (25) |
| 591-8016 | 5/8 (16) |
| 591-8017 | 5/8 (16) |
| 591-8018 | 3/4 (19) |
| 591-8019 | 3/4 (19) |
| 591-8020 | 1 (25) |
| 591-8021 | 1 (25) |
| 591-8028 | 5/8 (16) |
| 591-8029 | 3/4 (19) |
| 591-8030 | 1 (25) |
| 591-8071 | 3/8 (9.5) |
| 591-8072 | 3/4 (19) |
| 591-8073 | 3/4 (19) |
| 591-8074 | 1 (25) |
| 591-8075 | 1 (25) |
| 591-8076 | 1 (25) |
| 591-8077 | 3/8 (9.5) |
| 591-8078 | 3/4 (19) |
| 591-8079 | 3/4 (19) |
| 591-8080 | 1 (25) |

| Flowrite Product Number | Stem Travel in. (mm) |
|-------------------------|----------------------|
| 591-8081 | 1 (25) |
| 591-8082 | 1 (25) |
| 591-8330 | 5/8 (16) |
| 591-8331 | 5/8 (16) |
| 591-8332 | 3/4 (19) |
| 591-8336 | 5/8 (16) |
| 591-8337 | 5/8 (16) |
| 591-8338 | 3/4 (19) |
| 591-8339 | 3/4 (19) |
| 591-8340 | 1 (25) |
| 591-8341 | 1 (25) |
| 591-8342 | 1-1/2 (38) |
| 591-8344 | 1-1/2 (38) |
| 591-8350 | 1-1/2 (38) |
| 591-8351 | 1-1/8 (29) |
| 591-8352 | 1-1/8 (29) |
| 591-8353 | 1-1/8 (29) |
| 591-8354 | 1-1/8 (29) |
| 591-8355 | 1-1/8 (29) |
| 591-8356 | 1-1/8 (29) |
| 591-8357 | 1-1/8 (29) |
| 591-8358 | 1-1/4 (32) |
| 591-8359 | 1-1/8 (29) |
| 591-8360 | 1-1/2 (38) |
| 591-8362 | 1-1/2 (38) |
| 591-8364 | 1-1/8 (29) |
| 591-8365 | 1-1/8 (29) |
| 591-8366 | 1-1/8 (29) |
| 591-8367 | 1-1/8 (29) |
| 591-8368 | 1-1/8 (29) |
| 591-8369 | 1-1/8 (29) |
| 591-8370 | 1-1/8 (29) |
| 591-8371 | 1-1/8 (29) |
| 591-8372 | 1-1/4 (32) |
| 591-8373 | 1-1/4 (32) |
| 591-8374 | 1-1/2 (38) |
| 591-8376 | 1-1/2 (38) |
| 591-8378 | 1-1/4 (32) |
| 591-8379 | 1-1/4 (32) |
| 591-8380 | 1-1/4 (32) |

| Flowrite Product Number | Stem Travel in. (mm) |
|-------------------------|----------------------|
| 593-8381 | 1-1/4 (32) |
| 593-8382 | 1-1/2 (38) |
| 593-8383 | 1-1/2 (38) |
| 593-8388 | 3/4 (19) |
| 593-8389 | 3/4 (19) |
| 593-8390 | 3/4 (19) |
| 593-8391 | 3/4 (19) |
| 593-8392 | 1-1/8 (29) |
| 593-8393 | 1-1/8 (29) |
| 593-8394 | 1-1/4 (32) |
| 593-8395 | 1-1/4 (32) |
| 593-8396 | 1-1/4 (32) |
| 593-8397 | 1-1/4 (32) |
| 593-8398 | 1-1/4 (32) |
| 593-8399 | 1-1/4 (32) |
| 593-8400 | 1-1/4 (32) |
| 593-8401 | 1-1/4 (32) |
| 593-8402 | 1-1/2 (38) |
| 593-8403 | 1-1/2 (38) |
| 593-8404 | 1-1/4 (32) |
| 593-8405 | 1-1/4 (32) |
| 593-8406 | 1-1/4 (32) |
| 593-8407 | 1-1/4 (32) |
| 593-8410 | 1-1/2 (38) |
| 593-8411 | 1-1/2 (38) |
| 593-8412 | 1-3/8 (35) |
| 593-8413 | 1-3/8 (35) |
| 593-8415 | 1 (25) |
| 593-8416 | 1 (25) |
| 593-8419 | 1 (25) |
| 593-8420 | 1 (25) |
| 593-8421 | 1-3/8 (35) |
| 593-8422 | 1-3/8 (35) |
| 593-8423 | 1-3/8 (35) |
| 594-8343* | 1-1/2 (38) |
| 594-8345* | 1-1/2 (38) |
| 594-8361* | 1-1/2 (38) |
| 594-8363* | 1-1/2 (38) |
| 594-8375* | 1-1/2 (38) |
| 594-8377* | 1-1/2 (38) |

* RL 147 is standard with the product.

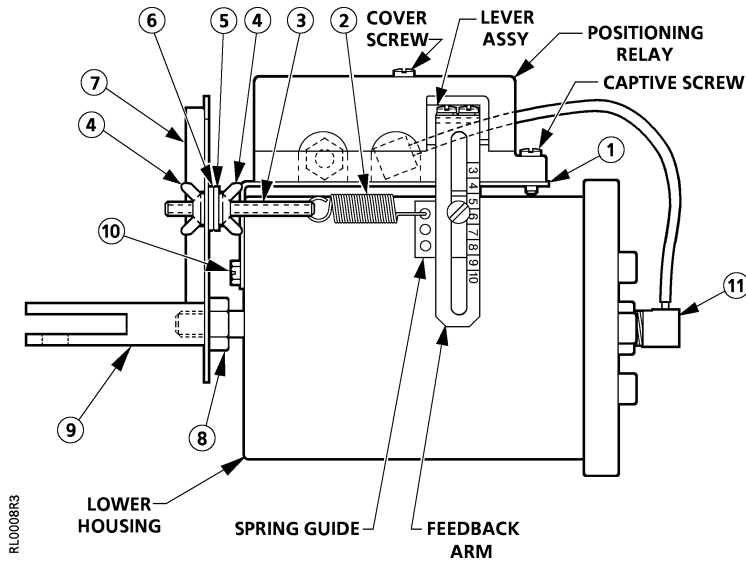

Figure 6. Positioning Relay Mounted on the No. 3 Damper Actuator.

Table 5. Mounting Kit 147-104 for the No. 3 Damper Actuator.

| Item | Description | Q'ty |
|------|---------------------------------------|------|
| 1 | Mounting Bracket | 1 |
| 2 | Feedback Spring (for 2-3/8" stroke) | 1 |
| 3 | Adjusting Screw 1-3/4" (44 mm) long | 1 |
| 4 | Wing Nut | 2 |
| 5 | Lock Washer | 1 |
| 6 | Flat Washer | 1 |
| 7 | Spring Arm | 1 |
| 8 | 3/8-24 Hex Nut | 1 |
| 9 | Clevis | 1 |
| 10 | #10-16 1/2" (13 mm) Slotted Hex Screw | 2 |
| 11 | 90° Elbow Connector | 1 |

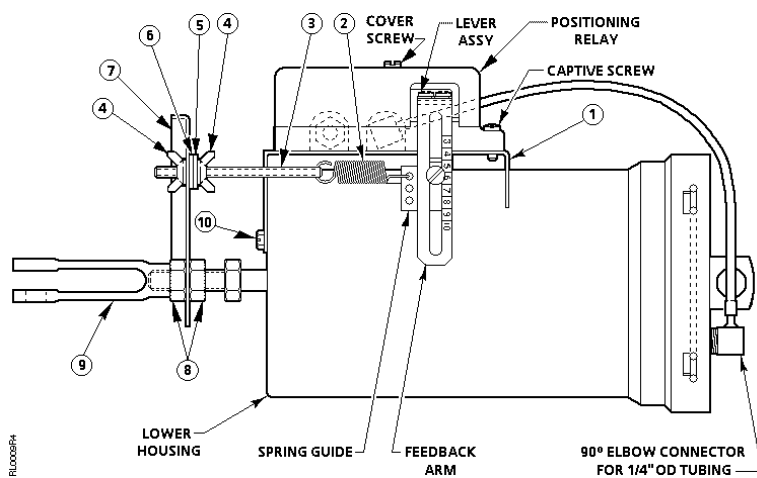

Figure 7. Positioning Relay Mounted on the No. 4 Damper Actuator.

Table 6. Mounting Kit 147-314 for the No. 4 Damper Actuator.

| Item | Description | Q'ty |
|------|---------------------------------------|------|
| 1 | Mounting Bracket | 1 |
| 2 | Feedback Spring | 1 |
| 3 | Adjusting Screw 1-3/4" (44 mm) long | 1 |
| 4 | Wing Nut | 2 |
| 5 | Lock Washer | 1 |
| 6 | Flat Washer | 1 |
| 7 | Spring Arm | 1 |
| 8 | 3/8-24 Hex Nut | 2 |
| 9 | Clevis | 1 |
| 10 | #10-16 1/2" (13 mm) Slotted Hex Screw | 1 |

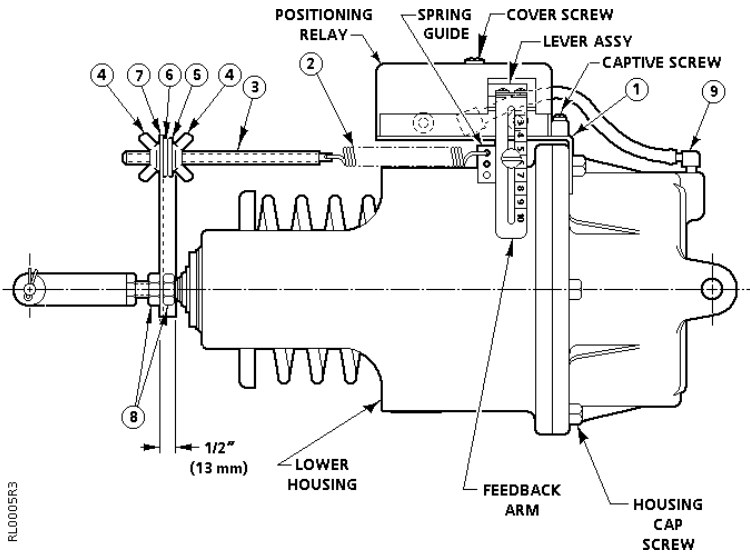

Figure 8. Positioning Relay Mounted on the No. 6 Damper Actuator.

Table 7. Spring Selection for Adjustable Stroke of the No. 6 Damper Actuator.

| Actuator Stroke | Feedback Spring | | | Adjusting Screw |
|--------------------------------|-----------------|---------|-------------|------------------|
| | Color | Nominal | Max | |
| 3-1/4 to 4 (82 to 102) | Blue | 4 (102) | 4-1/4 (108) | 4-1/2 (114) long |
| 2-29/32 to 3-1/4 (74 to 82) | Cadmium | 3 (76) | 3-1/4 (82) | 1-3/4 (44) long |

Table 8. Mounting Kit 147-276 for the No. 6 Damper Actuator.

| Item | Description | Q'ty |
|------|---|------|
| 1 | Mounting Bracket | 1 |
| 2 | Feedback Spring 4" (102 mm) stroke (blue) | 1 |
| | Feedback Spring 3" (76 mm) stroke (Cad.) | 1 |
| 3 | Adjusting Screw 4-1/2" (114 mm) long | 1 |
| | Adjusting Screw 1-3/4" (44 mm) long | 1 |
| 4 | Wing Nut | 2 |
| 5 | Lock Washer | 1 |
| 6 | Flat Washer | 1 |
| 7 | Spring Arm | 1 |
| 8 | 3/8-24 Hex Nut | 2 |
| 9 | 90° Elbow Connector | 1 |

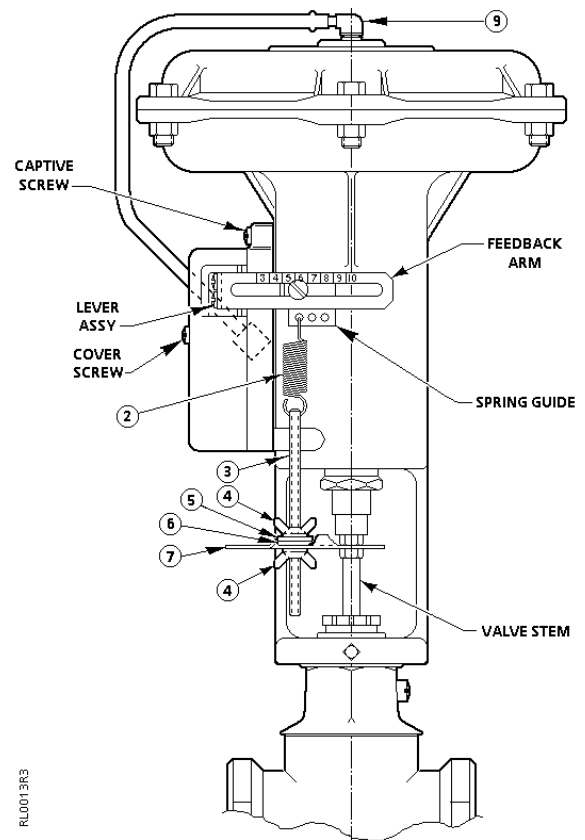

Figure 9. Positioning Relay Mounted on a VP 591 8" Valve Actuator.

Table 9. Mounting Kit 147-333 for the VP 591 8" Valve Actuator.

| Item | Description | Q'ty |
|------|----------------------------------|------|
| 2 | Feedback Spring-Small Cad. Plate | 2 |
| | Feedback Spring-Small Red | 1 |
| | Feedback Spring-Large Green | 1 |
| | Feedback Spring-Small Green | 2 |
| 3 | Adjusting Screw-4" (102 mm) long | 1 |
| 4 | Wing Nut | 2 |
| 5 | Lock Washer | 1 |
| 6 | Flat Washer | 1 |
| 7 | Spring Arm | 2 |
| 9 | 90° Elbow Connector | 1 |

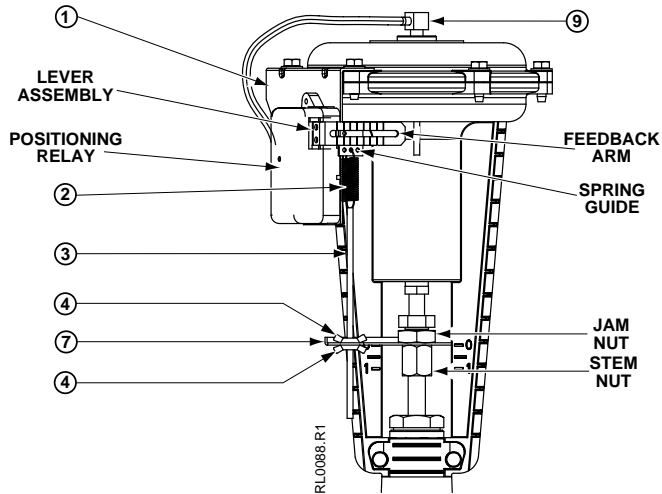

Figure 10. Positioning Relay Mounted on a Flowrite 599 Series 8" Valve Actuator.

Table 10. Kit 599-00426 for the Flowrite Series 599 8" Valve Actuator.

| Item | Description | Q'ty |
|------|--------------------------|------|
| | RL 147 Positioning Relay | 1 |
| 1 | Mounting Bracket | 1 |
| 2 | Feedback Spring | 1 |
| 3 | Adjusting Screw | 1 |
| 4 | Wing Nut | 2 |
| 7 | Spring Arm | 1 |
| 9 | 90° Elbow Connector | 1 |

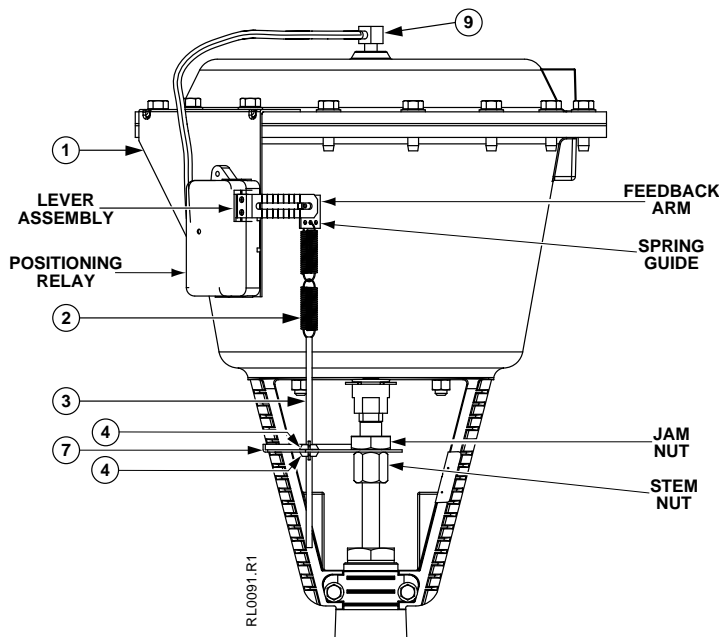

Figure 11. Positioning Relay Mounted on a Flowrite Series 599 12" Valve Actuator.

Table 11. Kit 599-00423 for the Flowrite Series 599 12" Valve Actuator.

| Item | Description | Q'ty |
|------|--------------------------|------|
| | RL 147 Positioning Relay | 1 |
| 1 | Mounting Bracket | 1 |
| 2 | Feedback Spring | 2 |
| 3 | Adjusting Screw | 1 |
| 4 | Wing Nut | 2 |
| 7 | Spring Arm | 1 |
| 9 | 90° Elbow Connector | 1 |

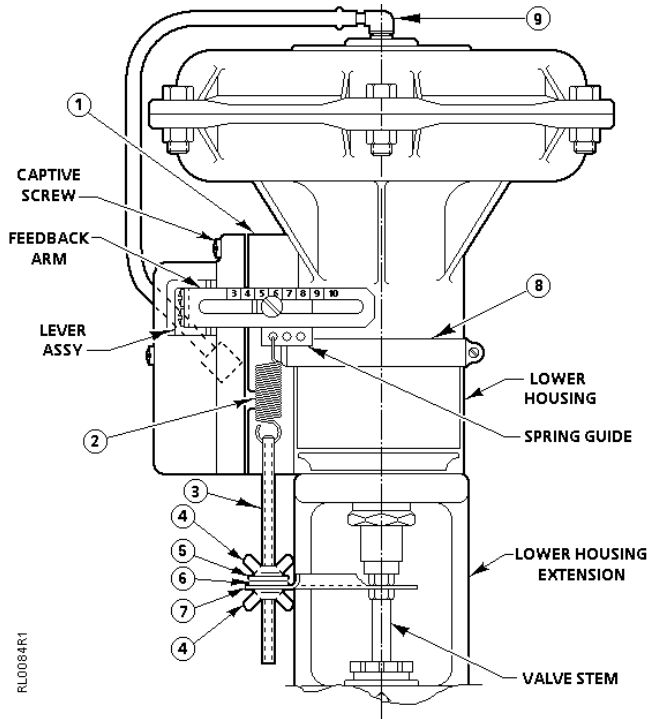

Figure 12. Positioning Relay Mounted on the Flowrite 8" Actuator (Models 1 & 2) and Super Flowrite.

Table 13. Mounting Kit for Super Flowrite and 12" Flowrite before March 1978. Refer to Figure 12.

| Item | Description | Q'ty |
|------|--------------------------------------|------|
| 1 | Mounting Bracket | 1 |
| 2 | Feedback Spring-Small Cad. Plate | 2 |
| | Feedback Spring-Small Red | 2 |
| | Feedback Spring-Large Green | 1 |
| 3 | Adjusting Screw-4-1/2" (114 mm) long | 1 |
| 4 | Wing Nut | 2 |
| 5 | Lock Washer | 1 |
| 6 | Flat Washer | 1 |
| 7 | Spring Arm | 1 |
| 8 | Sure-Tite Clamp | 1 |
| 9 | 90° Elbow Connector | 1 |

Table 12. Mounting Kit 147-277* for Flowrite 8" Valve Actuator (Models 1 & 2)

| Item | Description | Q'ty |
|------|--------------------------------------|------|
| 1 | Mounting Bracket | 1 |
| 2 | Feedback Spring-Small Cad. Plate | 2 |
| | Feedback Spring-Small Red | 1 |
| | Feedback Spring-Large Green | 1 |
| | Feedback Spring-Small Green | 2 |
| 3 | Adjusting Screw-4-1/2" (114 mm) long | 1 |
| 4 | Wing Nut | 2 |
| 5 | Lock Washer | 1 |
| 6 | Flat Washer | 1 |
| 7 | Spring Arm | 1 |
| 8 | Sure-tite Clamp | 1 |
| 9 | 90° Elbow Connector | 1 |

*Also order spring arm # 147-307 for use with VF 5915" and 6" balanced valves.

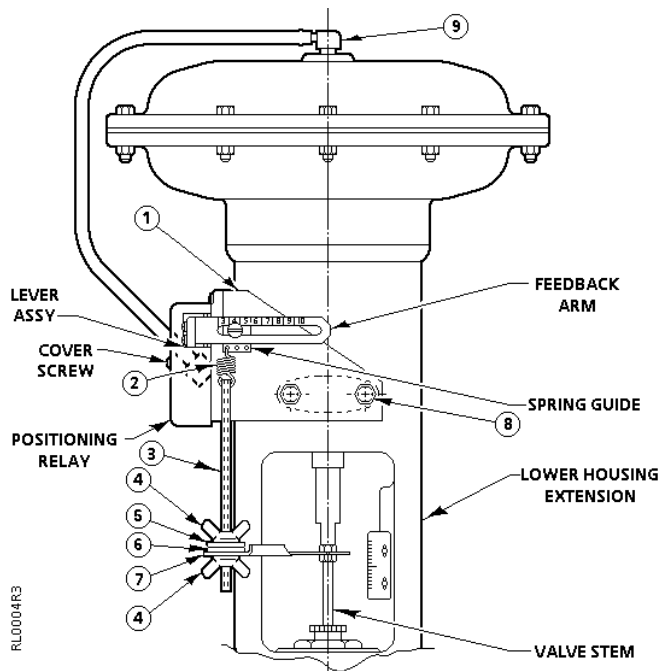

Table 14. Mounting Kit 147-311 for the VP 591/3 Flowrite Valve Actuator.

| Item | Description | Q'ty |
|------|--------------------------------------|------|
| 1 | Mounting Bracket | 1 |
| 2 | Feedback Spring-Small Cad. Plate | 2 |
| | Feedback Spring-Small Red | 2 |
| | Feedback Spring-Large Green | 2 |
| 3 | Adjusting Screw-6-1/2" (165 mm) long | 1 |
| 4 | Wing Nut | 2 |
| 5 | Lock Washer | 1 |
| 6 | Flat Washer | 1 |
| 7 | Spring Arm | 1 |
| 8 | 5/16-18 x 1/2 long Cap Screw | 2 |
| 9 | 90° Elbow Connector | 1 |

Figure 13. Positioning Relay Mounted on a VF 591/3 Flowrite Valve Actuator.

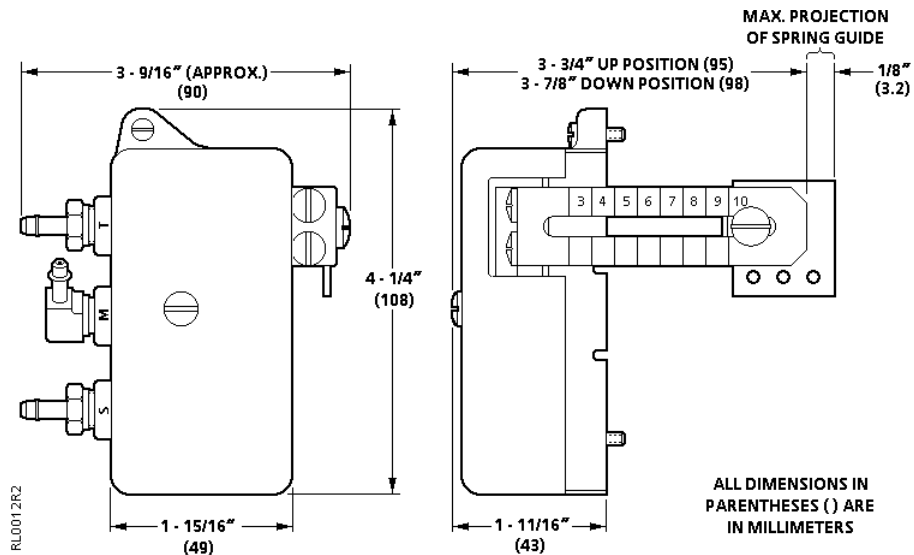

Figure 14. Dimensions in inches (millimeters).

Information in this publication is based on current specifications. The company reserves the right to make changes in specifications and models as design improvements are introduced.

Landis & Gyr, Inc. • 1000 Deerfield Parkway, Buffalo Grove, Illinois 60089