

THIS DOCUMENT AND THE INFORMATION CONTAINED HEREIN ARE PROPRIETARY TO LAARS HEATING SYSTEMS CO. AND SHALL NOT BE REPRODUCED, TRANSFERRED TO OTHER DOCUMENTS, USED OR DISCLOSED TO OTHERS FOR MANUFACTURING OR ANY OTHER PURPOSE EXCEPT AS SPECIFICALLY AUTHORIZED IN WRITING BY LAARS HEATING SYSTEMS CO.

REVISIONS					
REV.	ECN	DRAFT	CHECK	ENGR APPR	APPR
C	12-131N	PM 9-24-12		SD 9-24-12	

CHANGE: A2117201: TACO MODEL WAS HPL-33-L, LENGTH WAS 15.3, A2117202: TACO MODEL WAS HPL-50-L, RPM WAS 1725, LENGTH WAS 16.10, A2117203: TACO MODEL WAS HPL-75-L SERV. FACTOR WAS 1.5, RPM WAS 1725, LENGTH WAS 16.9, A2117204: TACO MODEL WAS HPL-100-L, NOTE 4C WAS MOTOR BRACKET: CLASS 30A CAST IRON, ASTM A48

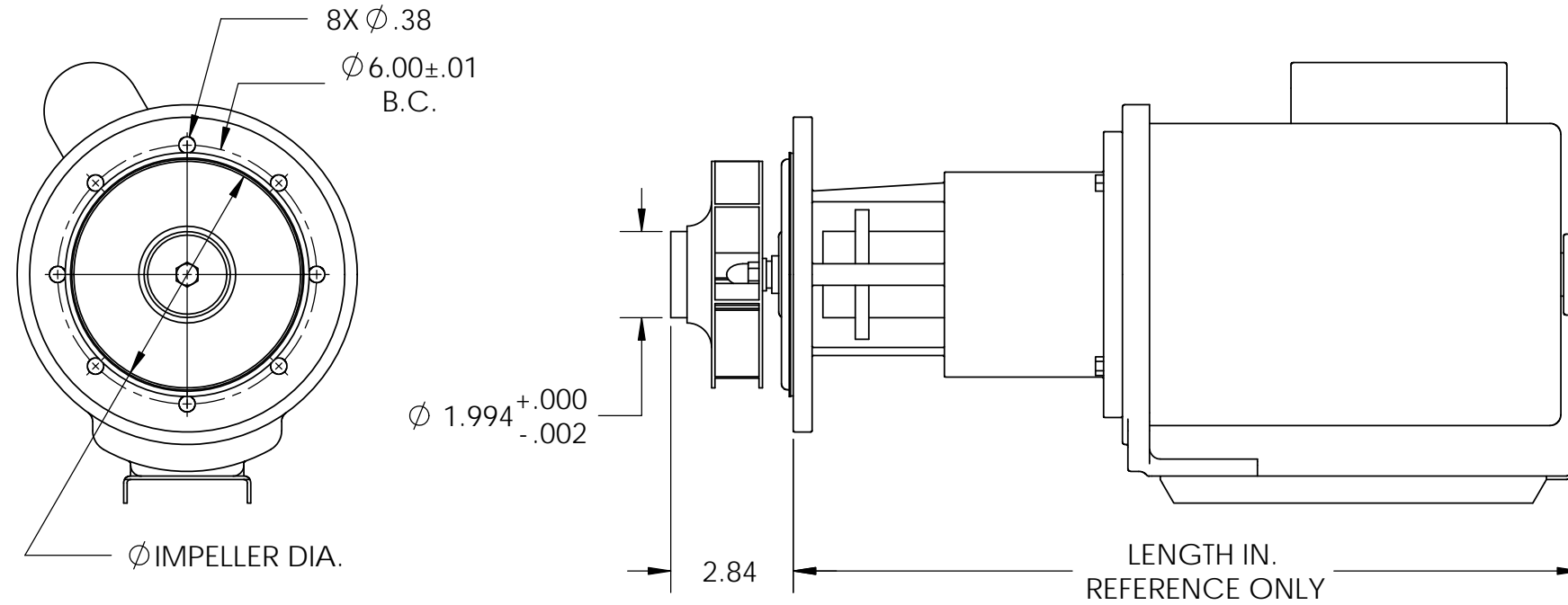

NOTES:

- GENERAL DESCRIPTION: CENTRIFUGAL PUMP, ROTARY ASSEMBLY LESS VOLUTE.
- MANUFACTURER: TACO INC. CRANSTON, R.I.
- PUMP DATA: REFER TO TABLE
- MATERIAL:
 - A) IMPELLER: LOW LEAD COPPER ALLOY
 - B) SHAFT: STAINLESS STEEL
 - C) MOTOR BRACKET: FRONT: CAST IRON ASTM A159-83 GRADE G3000. REAR: 1010/1008 STEEL.
- SHIPPING CONTAINER AND PUMP MUST BE CLEARLY MARKED WITH THE APPROPRIATE LAARS P/N

A2117204	PUMP, TACO, 1 HP, "HPL-L" MODEL	5.25	1	60	50°C	1	1.5	1760	HPL-100L-B	115	18.2
A2117203	PUMP, TACO, 3/4 HP, "HPL-L" MODEL	4.75	3/4	60	50°C	1	1.4	1760	HPL-75L-B	115	17.2
A2117202	PUMP, TACO, 1/2 HP, "HPL-L" MODEL	4.00	1/2	60	50°C	1	1.5	1760	HPL-50L-B	115	16.7
A2117201	PUMP, TACO, 1/3 HP, "HPL-L" MODEL	3.62	1/3	60	50°C	1	1.3	1725	HPL-33L-B	115	16.2
LAARS P/N	DESCRIPTION	IMPELLER DIA.	HP	HZ	MAX AMBIENT TEMP.	PHASE	SERVICE FACTOR	SPEED RPM	TACO MODEL NO.	VOLTAGE	LENGTH IN. REFERENCE

UNLESS OTHERWISE SPECIFIED:
 TOLERANCES ARE:
 DECIMALS .X $\pm .1$ FRACTIONS $\pm 1/8$ "
 DECIMALS .XX $\pm .03$
 DECIMALS .XXX $\pm .010$
 ANGLES $\pm 1^\circ$

DO NOT SCALE DRAWING.
 THIRD ANGLE PROJECTION.
 DIMENSIONS ARE IN INCHES.

MATERIAL:
 SEE NOTES

FINISH
 NA

APPROVALS
 DRAFT
 JM 12-28-09
 ENGR
 APPR
 CJH 1/6/10

LAARS
 Heating Systems Company

TITLE:
 PUMP, TACO, "HPL- L MODELS"

INTENDED SIZE: **B** SOFTWARE: **S** DWG. NO: **A21172** REV: **C**

SCALE: NONE SHEET 1 OF 1