



Cleveland Controls
Division of UniControl Inc.

Model
AFS-952

Adjustable Set Point Air Pressure Sensing Switch with 8-second Time Delay



AFS-952 in Standard Enclosure,
rated NEMA-1.



AFS-952-1 in NEMA-4 rated
Enclosure.



AFS-952-2 in NEMA-7 and
NEMA-9 rated Enclosure.

Description & Operation

The **Cleveland Controls AFS-952 Differential Pressure Sensing Switch** is designed to provide precise operation and convenient features for industrial and commercial air handling applications. The **AFS-952** can monitor positive, negative, or differential pressure (flow) of air and non-combustible gases, and is commonly used to monitor combustion air, furnace pressure, ventilating blower operation, inflatable structure pressure, fume hood operation, bag house air flow, dirt accumulation in air filters, and heat-transfer air flow. The **AFS-952** has a field-adjustable set point range of 0.05"wc to 12.0"wc with an 8-second (± 3 seconds) time delay relay sequence. The time delay prevents nuisance shutdowns due to normal draft fluctuations.

Common Applications

The most common specific application for the AFS-952 is as a **Low Draft (Negative Pressure) Cutoff Safety Switch** for combustion draft control systems.

The general applications of the **AFS-952** are:

- **Low Positive Pressure Cutoff.** (Shutdown upon insufficient pressure.)
- **Low Negative Pressure Cutoff.** (Shutdown upon insufficient draft.)
- **Low Differential Pressure Cutoff.** (Shutdown upon insufficient difference between two samples.)

Mounting

The **AFS-952** is available in 3 enclosures designed for surface mounting on any flat, relatively stable surface free of vibration. To obtain the lowest operating set point specification, the control must be mounted with the diaphragm vertical (Fig 1).

The standard enclosure has mounting flanges with four 9/32" mounting holes as shown on page 3. The NEMA-4 rated model has mounting flanges with four 5/16" mounting holes as shown on page 4. The NEMA-7/NEMA-9 rated enclosure has two mounting slots as shown on page 4.

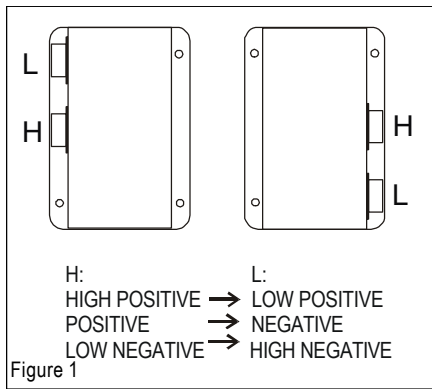

Piping

The field sample line connectors, two 1/4" - 18 NPT female fittings, labeled **H (high)** and **L (low)**, are located on the side of the enclosure as shown in Figure 1.

Positive Pressure only:

Connect sample line to **H**;
L remains open to the atmosphere.

Negative Pressure only:

Connect sample line to **L**;
H remains open to the atmosphere.

Two Negative Samples:

Connect higher negative sample to **L**;
 Connect lower negative sample to **H**.

Two Positive Samples:

Connect higher positive sample to **H**;
 Connect lower positive sample to **L**.

One Negative and One Positive Sample:

Connect positive sample line to **H**;
 Connect negative sample line to **L**.

For each right angle bend, add four feet to the computed line length in order to determine correct pipe or tubing size.

If either sample line connector is vented to the atmosphere, attach an elbow to it so that the open end of the connector points downward. This will help protect the switch from contamination.

Electrical Connections

Five numbered terminals are provided for field wiring. Terminals are pressure clamp screw type.

Figure 2: Electrical Connections

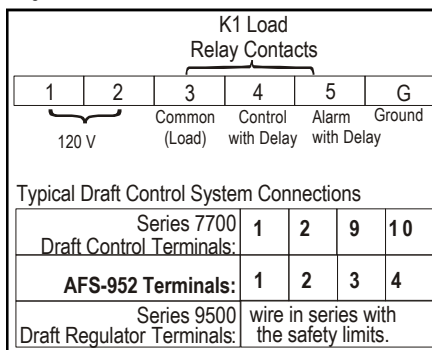

Sequence of Operation

Before pressure and power are applied to the AFS-952, the SPDT switch contacts are in the normally closed position as shown in **Figure 3** ("shelf" condition), and relay contacts 3 and 5 are closed ("alarm mode").

When the sample lines are connected as shown in **Figure 1**, and power is applied to terminals 1 and 2, the following sequence occurs.

Initially the red lamp is on, indicating that differential pressure is less than set point. The SPDT switch contacts remain in the NC position for as long as differential pressure remains less than set point; the TD1 time delay is not energized and the K1 load relay circuit remains in alarm mode. When differential pressure reaches set point, the SPDT switch contacts change to NO immediately so that the red lamp goes out and the TD1 time delay is energized. If the TD1 time delay remains energized for 8 ± 3 seconds continuously, the TD1 contacts close, energizing the K-1 coil and opening K-1 load contacts 3 and 5. The circuit is now in normal operating mode.

Whenever differential pressure drops below the set point, the SPDT switch contacts change to NC immediately, turning the red lamp on, and de-energizing the TD1 time delay. **The K-1 load contacts for terminals 3 and 5 remain open unless differential pressure remains less than set point for 8 seconds continuously.** After this 8-second period, K-1 load relay contacts 3 and 5 close while K1 contacts 3 and 4 open: the circuit is now in **alarm mode**.

When the differential pressure becomes greater than set point, the SPDT switch contacts change to NO immediately, turning the red lamp off, and energizing the TD1 time delay. The differential pressure must remain greater than set point for 8 seconds continuously before the K-1 load relay contacts open contacts 3 and 5.

Field Adjustments

Field adjustments to the operating set point are made by removing the protective plug button on the side of the control enclosure and inserting a standard blade-type screwdriver, at least 3 inches long*.

The adjustment range is **0.05 ± .02" w.c. to 12.0" w.c.** To adjust the set point,

Model AFS-952 Air Pressure Sensing Switch

Mounting Position: Mount with the diaphragm in any vertical plane.

Set Point Range: 0.05 ± 0.02" w.c. to 12.0"w.c. (1.3 to 305 mm wc; 0 to 0.43 psi).

Field Adjustable "Operate Range": 0.07"w.c. to 12.0" w.c.

Field Adjustable "Release Range": 0.04"w.c. to 11.2" w.c.

Approximate Switching Differential: Progressive, increasing from 0.02± 0.01"w.c. at minimum set point to approximately 0.8" w.c. at maximum set point. (0.5 ± .25 mm to approximately 20.3 mm).

Operating Temperature Range: 0F to 130F (-18 to 54.4C).

Measured Media: Air or combustion by-products that will not degrade silicone.

Maximum Pressure: ½ psi (0.03 bar).

Life: 100,000 cycles minimum at 1/2 psi maximum pressure each cycle and at maximum rated electrical load.

Electrical Rating-Relay Switching Capacity:

720 va at 120 vAC at 50/60 Hz.

10 amps at 120 vAC,

5 amps at 240 vAC resistive load.

Power consumption: 4.5 watts at 120 vAC.

Contact Arrangement: SPDT NC (single pole, double-throw snap action switch; contacts are in normally closed position before pressure is applied to the diaphragm.)

Electrical Connections: 5 numbered terminals, pressure clamp screw type.

Conduit Opening: 7/8" diameter opening accepts 1/2" conduit.

Sample Line Connectors: Two ¼"—18 NPT female fittings.

Approval: FM approved.

Shipping Weight:

AFS - 952 (std. enclosure): **5 lbs.**

AFS - 952 - 1 NEMA 4 enclosure: **8 lbs.**

AFS - 952 - 2 NEMA 7/9 enclosure: **18 lbs.**

turn the adjusting screw counterclockwise until motion has stopped. Next, turn the adjusting screw **4 complete turns** in a clockwise direction to engage the spring. For the **next 10 turns, each full turn represents approximately 1.2" w.c.** At higher operating pressures, there is a slight increase in the switching differential. **Please note:** To properly calibrate an air pressure sensing switch, a digital manometer or other measuring device should be used to confirm the actual set point.

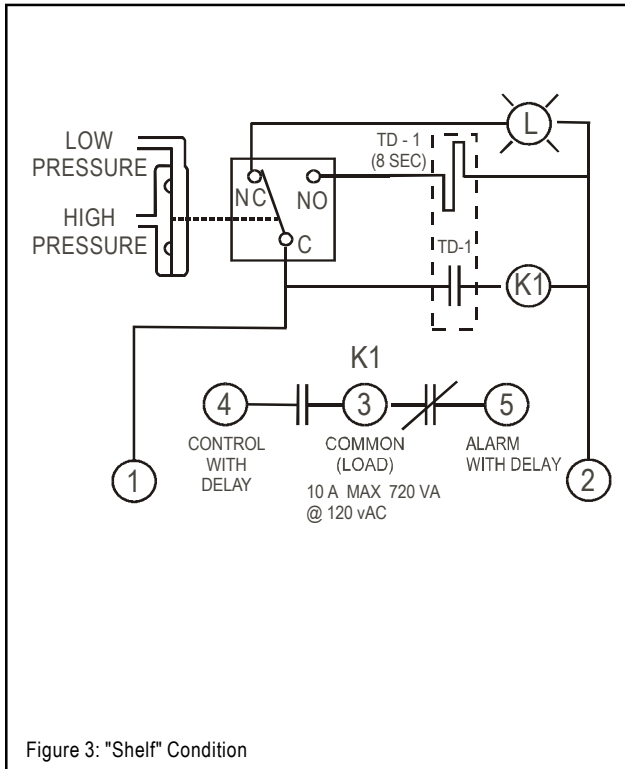
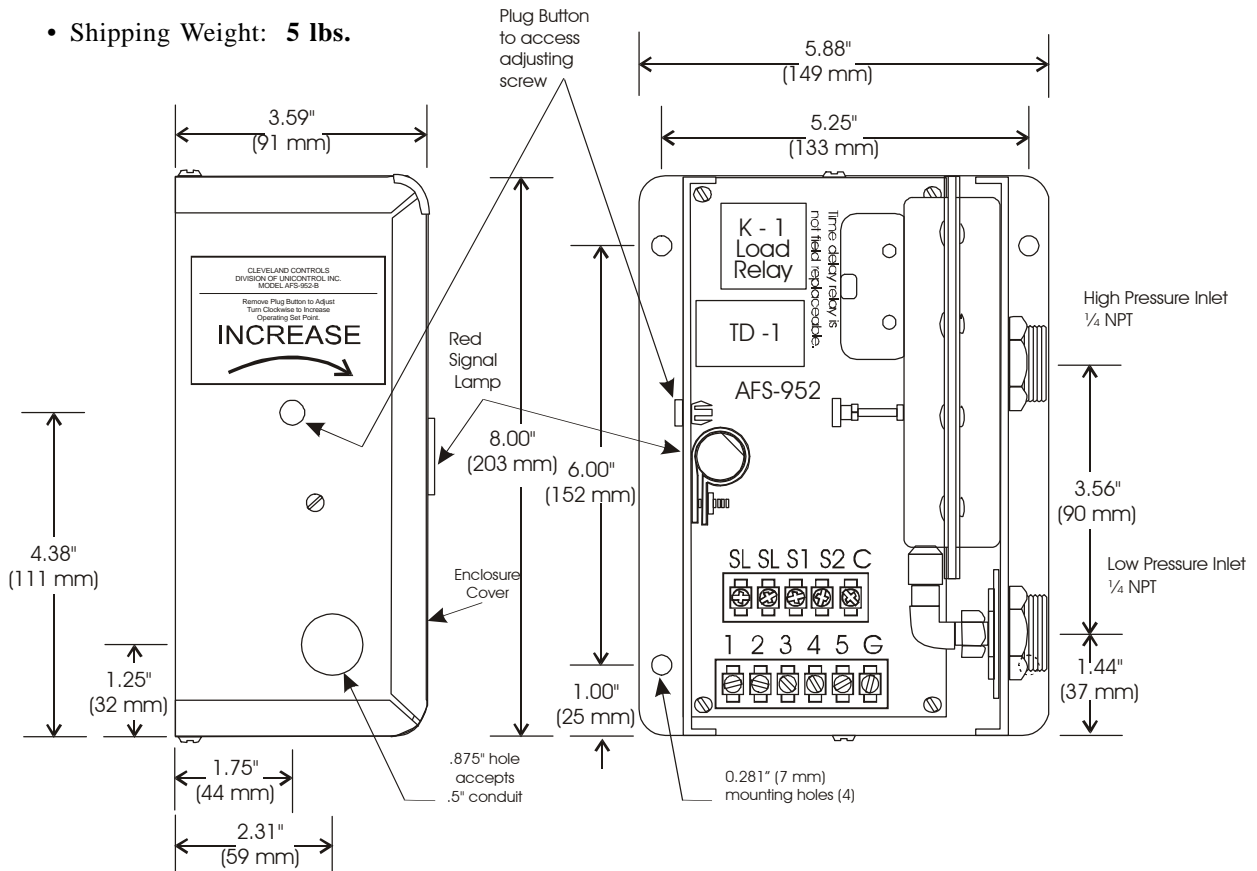

Figure 3: "Shelf" Condition

Contact Position			
Condition	K-1 Load Relay Contacts		Red Lamp
	3 - 4	3 - 5	
On Shelf (Figure 3).	Open	Closed	Off
Power Applied; Differential Pressure above Set Point (Immediate).	Open	Closed	Off
Power Applied; Differential Pressure above Set Point (After 8 seconds).	Closed	Open	Off
Power Applied; Differential Pressure below Set Point (Immediate).	Closed	Open	On
Power Applied; Differential Pressure below Set Point (After 8 seconds).	Open	Closed	On

Model AFS-952 in Standard NEMA-1 rated housing:

- Coated steel finish.
- Shipping Weight: **5 lbs.**



ENCLOSURE SPECIFICATIONS & DIMENSIONS

Model AFS-952-1:

14-gauge grey hammertone enameled steel with neoprene gasketed clamped cover hinged on the left side. **NEMA 4** rated: provides protection from dust, dirt, oil, and water.

Shipping Weight: **8 lbs.**

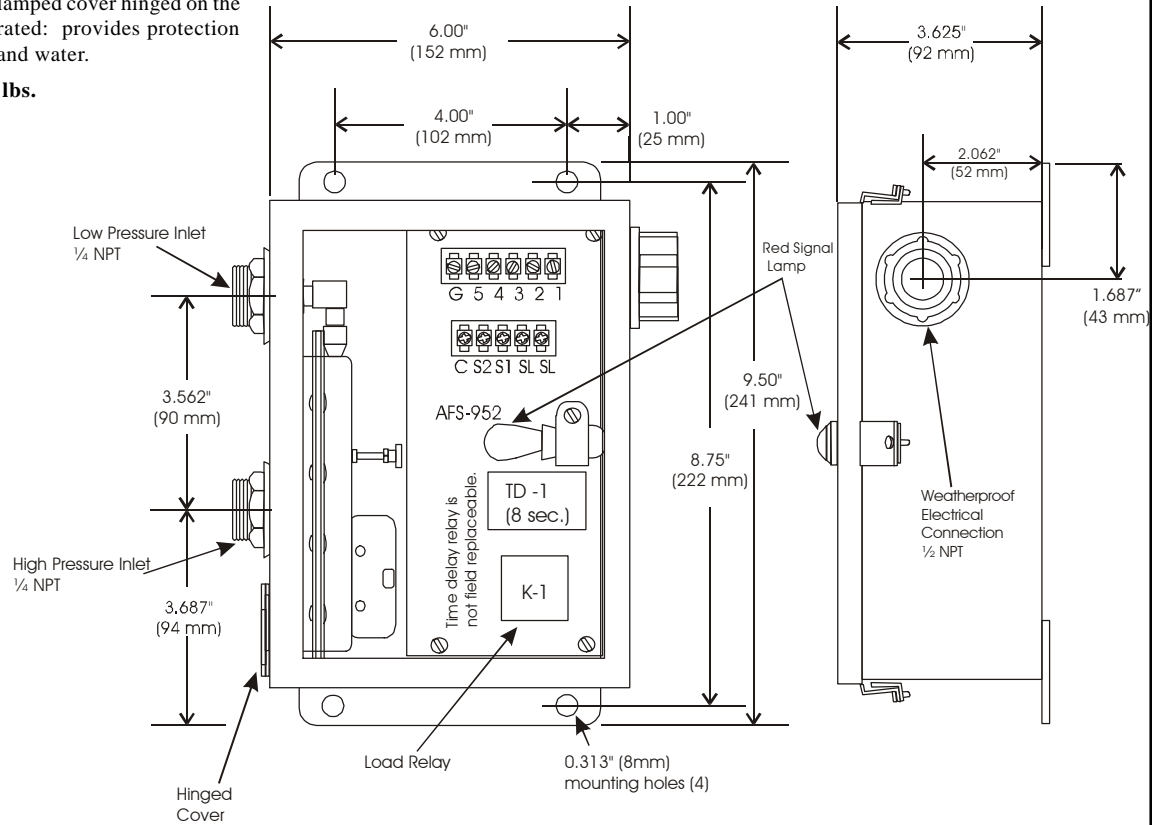

Model AFS-952-2:

Red lamp not available.

Cast aluminum alloy, nonmagnetic, non-sparking, and non-rusting. **NEMA 7** and **NEMA 9** rated. **UL** approved for **Class 1, Group D; Class II Groups E, F, G.**

Piping: Either pressure inlet, if not connected to a pressure sample, must be piped and vented to a nonhazardous area.

Shipping Weight: **18 lbs.**

