



Cleveland Controls

Division of UniControl Inc.

Model

AFS-262-112

AIR PRESSURE SENSING SWITCH WITH ADJUSTABLE SET POINT RANGE

APPLICATION

Model AFS-262-112 Air Pressure Sensing Switch is a general purpose proving switch designed for HVAC and Energy Management applications. It may be used to sense positive, negative, or differential air pressure. The AFS-262-112 is equipped with convenient barbed sample line connectors that accept flexible tubing.

GENERAL DESCRIPTION & OPERATION

The plated housing contains a diaphragm, a calibration spring and a snap-acting SPDT switch. The barbed sample line connections located on each side of the diaphragm accept flexible tubing.

An enclosure cover guards against accidental contact with the live switch terminal screws and the set point adjusting screw. The enclosure cover will accept a 1/2" conduit connection.

MOUNTING (SEE FIGURE 1)

Select a mounting location which is free from vibration. The **AFS-262-112** must be mounted with the diaphragm in any vertical plane in order to obtain the lowest specified operating set point. Avoid mounting with the sample line connections in the "up" position. Surface mount via the two 3/16" diameter holes in the

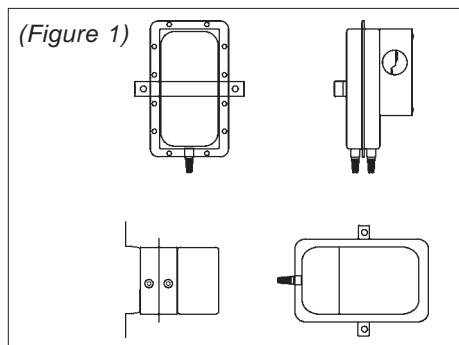

AIR SAMPLING CONNECTION (SEE FIGURE 2)

integral mounting bracket. The mounting holes are 3-7/8" apart.

The **AFS-262-112** is designed to accept flexible tubing by means of barbed 1/4" slip-on connections. For sample lines of up to 10 feet, 1/4" OD tubing is acceptable. For lines up to 20 feet, use 1/4" ID tubing. For lines up to 60 feet, use 1/2" ID tubing. Locate the sampling probe a minimum of 1.5 duct diameters downstream from the air source. Install the sampling probe as close to the center of the airstream as possible. Refer to Figure 2 to identify the high pressure inlet (H) and the low pressure inlet (L). Connect the sample lines as follows:

POSITIVE PRESSURE ONLY: Connect the sample line to inlet H; inlet L remains open to the atmosphere.

NEGATIVE PRESSURE ONLY: Connect the sample line to inlet L; inlet H remains open to the atmosphere.

TWO NEGATIVE SAMPLES: Connect the higher negative sample to inlet L. Connect the lower negative sample to inlet H.

TWO POSITIVE SAMPLES: Connect the higher positive sample to inlet H. Connect the lower positive sample to inlet L.

ONE POSITIVE AND ONE NEGATIVE SAMPLE: Connect the positive sample to inlet H. Connect the negative sample to inlet L.



Cleveland Controls

DIVISION OF UNICONTROL INC.
1111 Brookpark Rd
Cleveland OH 44109

Tel: 216-398-0330

Fax: 216-398-8558

Email: sales HVAC@unicontrolinc.com

Web page: <http://www.clevelandcontrols.com>

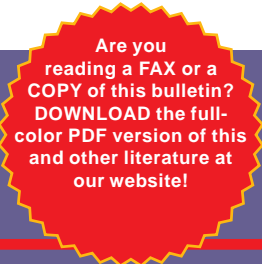

(Figure 2)

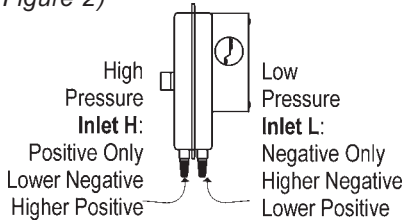

(Figure 3)

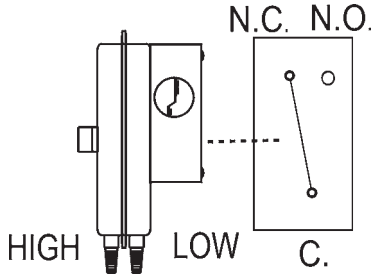

(Figure 4)

To prove excessive air flow or pressure:

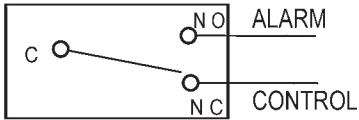

To prove insufficient air flow or pressure:

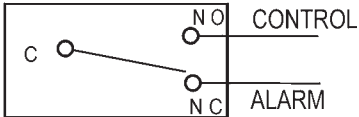

ELECTRICAL CONNECTIONS (SEE FIGURE 3)

Before pressure is applied to the diaphragm, the switch contacts will be in the normally closed (NC) position. The snap switch has screw top terminals with cup washers. Wire alarm and control applications as shown in Figure 4.

FIELD ADJUSTMENT

The adjustment range of an **AFS-262-112** Air Switch is 0.05 ± 0.02 " w.c. to 2.0" w.c. To adjust the set point, turn the adjusting screw counterclockwise until motion has stopped. Next, turn the adjusting screw 4 complete turns in a clockwise direction to engage the spring. From this point, the next ten turns will be used for the actual calibration. **Each full turn represents approximately 0.2" w.c.**

Please note: To properly calibrate an air switch, a digital manometer or other measuring device should be used to confirm the actual set point.

SPECIFICATIONS

MODEL AFS-262-112 AIR PRESSURE SENSING SWITCH WITH ADJUSTABLE SET POINT RANGE

Mounting Position: Mount with the diaphragm in any vertical plane.

Set Point Range: 0.05 ± 0.02 " w.c. to 2.0" w.c.

Field Adjustable "Operate Range": 0.07" w.c. to 2.0" w.c.

Field Adjustable "Release Range": 0.04" w.c. to 1.9" w.c.

Approximate Switching Differential: Progressive, increasing from 0.02 ± 0.01 " w.c. at minimum set point to approximately 0.1" w.c. at maximum set point.

Measured Media: Air, or combustion by-products that will not degrade silicone.

Maximum Pressure: 1/2 psi (0.03 bar).

Operating Temperature Range: -40F to 180F (-40 to 82C).

Life: 100,000 cycles minimum at 1/2 psi maximum pressure each cycle and at maximum rated electrical load.

Electrical Rating:

300 VA pilot duty at 115 to 277 VAC, 15 amps noninductive to 277 VAC, 60 Hz.

Contact Arrangement: SPDT.

Electrical Connections: Screw-type terminals with cup washers.

Conduit Opening: 7/8" diameter opening accepts 1/2" conduit.

Sample Line Connectors: Two barbed 1/4" connectors will accept flexible tubing.

Sample Line Connections: Two barbed 1/4" connectors will accept flexible tubing.

Approval: UL, FM, CSA, CE

Shipping Weight: 1.2 lbs.

Accessories:

- Sample line probes.
- Orifice plugs (pulsation dampers).

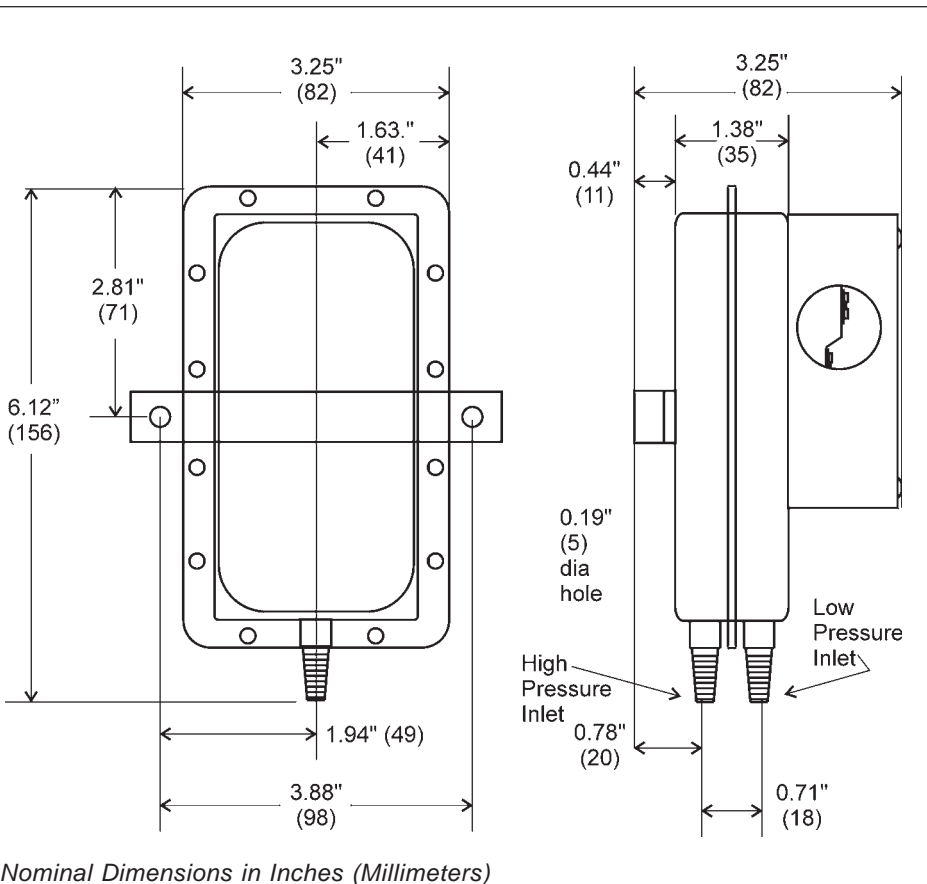

Nominal Dimensions in Inches (Millimeters)