



Cleveland Controls

Division of UniControl Inc.

Model

AFS-460-DSS

ADJUSTABLE SET POINT AIR PRESSURE SENSING SWITCH WITH DUAL MANUAL RESET

APPLICATION

The **Model AFS-460-DSS** is a general purpose airflow proving switch designed for 120 VAC HVAC and Energy Management applications where dual manual reset switches with SPST contacts are needed. It may be used to sense positive, negative, or differential air pressure.

GENERAL DESCRIPTION & OPERATION

The plated housing contains a diaphragm, a calibration spring, and 2 snap-acting switches with a single manual reset button.

The sample connections located on each side of the diaphragm accept .25" (6.35 mm) OD tubing via the integral compression ferrule and nut.

An enclosure cover guards against accidental contact with the live switch terminal screws and the set point adjusting screw. The enclosure cover accepts two 0.5" (12.7 mm) conduit connections. The manual reset button is located on the top surface of the enclosure cover.

MOUNTING (SEE FIGURE 1)

Select a mounting location which is free from vibration. The **AFS-460-DSS** must be mounted with the diaphragm in any vertical plane in order to obtain the lowest specified operating set point. Avoid

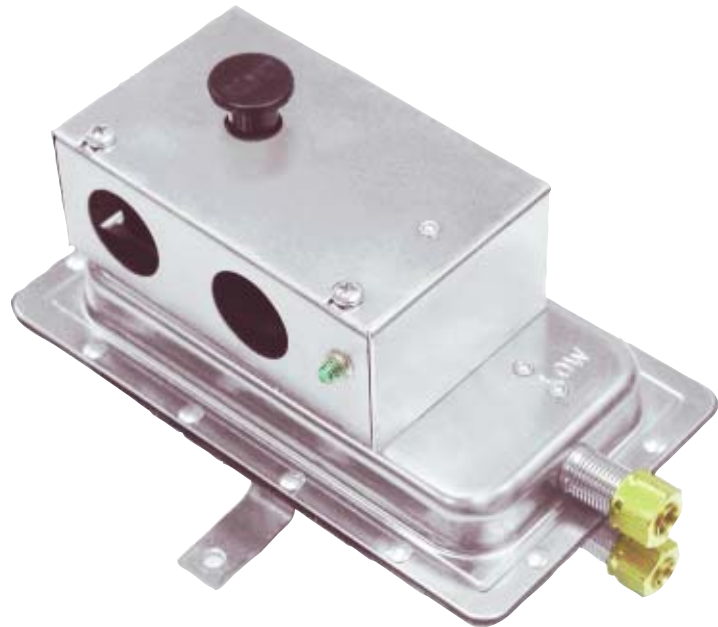
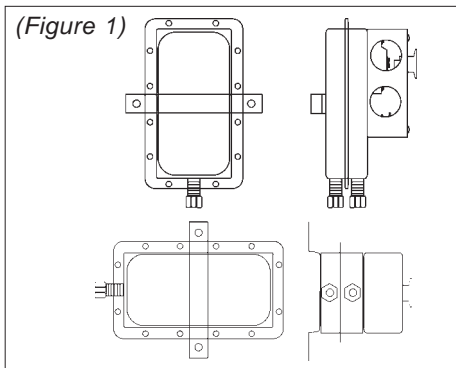

mounting with the sample line connections in the "up" position. Surface mount via the two 3/16" (4.75 mm) diameter holes in the integral mounting bracket. The mounting holes are 3-7/8" (98.4 mm) apart.

AIR SAMPLING CONNECTION (SEE FIGURE 2)

The **AFS-460-DSS** is designed to accept firm-wall sample lines of 1/4" (6.35 mm) OD tubing by means of ferrule and nut compression connections. An optional 1/4" (6.35 mm) adapter, suitable for slip-on flexible tubing is available. For sample lines of up to 10 feet (3.05 metres), 1/4" (6.35 mm) OD tubing is acceptable. For lines up to 20 feet (6.1 metres), use 1/4" (6.35 mm) ID tubing. For lines up to 60 feet (18.3 metres), use 1/2" (12.7 mm) ID tubing. Locate the sampling probe a minimum of 1.5 duct diameters downstream from the air source. Install the sampling

probe as close to the center of the airstream as possible. Refer to **Figure 2** to identify the high pressure inlet (H), and the low pressure inlet (L). Select one of the five application options listed below, and connect the sample lines as recommended. **POSITIVE PRESSURE ONLY:** Connect the sample line to inlet H; inlet L remains open to the atmosphere.

NEGATIVE PRESSURE ONLY: Connect the sample line to inlet L; inlet H remains open to the atmosphere.

TWO NEGATIVE SAMPLES: Connect the higher negative sample to inlet L. Connect the lower negative sample to inlet H.

TWO POSITIVE SAMPLES: Connect the higher positive sample to inlet H. Connect the lower positive sample to inlet L.

ONE POSITIVE AND ONE NEGATIVE SAMPLE: Connect the positive sample to inlet H. Connect the negative sample to inlet L.



Cleveland Controls

DIVISION OF UNICONTROL INC.
1111 Brookpark Rd
Cleveland OH 44109

Tel: 216-398-0330

Fax: 216-398-8558

Email: sales HVAC@unicontrolinc.com

Web page: <http://www.clevelandcontrols.com>

Are you reading a FAX or a COPY of this bulletin? DOWNLOAD the full-color PDF version of this and other literature at our website!

ELECTRICAL CONNECTIONS

(SEE FIG. 3)

Before pressure is applied to the diaphragm, the snap switch contacts will be in the normally closed (NC) position as shown in Fig. 3.

The snap switches have screw top terminals with cup washers. Wire alarm and control applications as shown in Fig. 4.

FIELD ADJUSTMENT:

LEAD & LAG SNAP SWITCHES (SEE FIG. 4)

The AFS-460-DSS Manual Reset Air Switch has a lead snap switch adjustment of **1.25" w.c. to 12.0" w.c.** (31.8 mm w.c. to 305 mm w.c.) The set point adjusting screw is used to adjust the set point of the lead snap switch (**Switch A, in Fig. 4**). The lag snap switch (**Switch B, in Fig. 4**) operates after the lead snap switch at progressively increasing set point increments as indicated in **Table 1, below**. **Note:** if **simultaneous** operation of Switch A and Switch B is required, use **Model AFS-460-136** or **AFS-460-137**.

To adjust the set point of Switch A: Turn the adjusting screw counterclockwise until motion has stopped. Next, turn the adjusting screw **four** complete turns in a clockwise direction to engage the spring. From this point, the next **ten** turns will be used for the actual calibration. **Each full turn represents approximately 1.0" w.c. (25.4 mm w.c.).** Please **note:** To properly calibrate an air switch, a digital manometer or other measuring device should be used to confirm the actual set point.

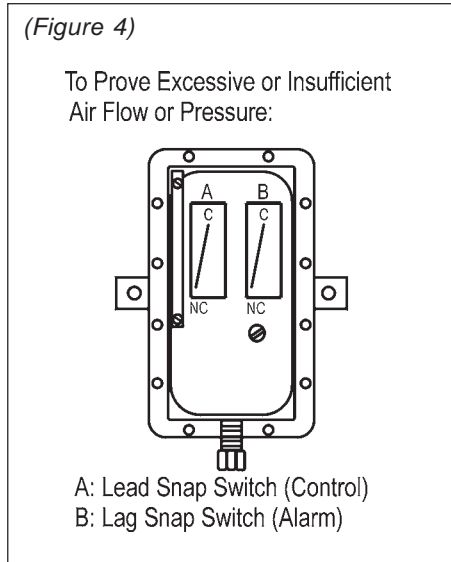
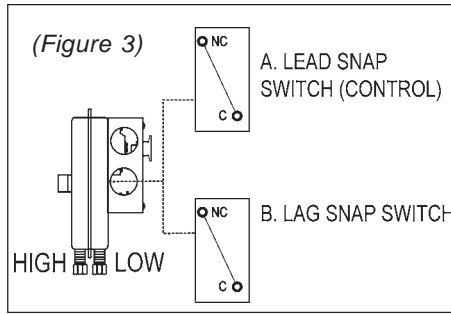
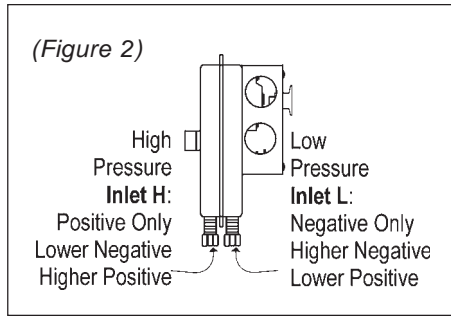

SPECIFICATIONS

MODEL AFS-460-DSS AIR PRESSURE SENSING SWITCH WITH MANUAL RESET & DUAL SPST-NC CONTACT ARRANGEMENT

Mounting Position (in order to meet lowest operating specifications): Mount with the diaphragm in any vertical plane.

Set Point Range:

1.25 ± 0.06" w.c. to 12.0" w.c. (31.8mm ± 1.52mm w.c. to 305 mm w.c.)

Field Adjustable "Operate Range":

1.31" w.c. to 12.0" w.c.

Field Adjustable "Release Range":

1.31" w.c. to 11.2" w.c.

Approximate Switch Differential: Progressive, increasing from approximately 0.06 ± 0.01" w.c. at minimum set point, to approximately 0.8" w.c. at maximum set point.

Measured Media: Air, or combustion by-products that will not degrade silicone.

Maximum Pressure: ½ psi (0.03 bar; 3.45 kPa)

Life: Exceeds UL-recognized mechanical endurance test of 6,000 cycles minimum at 0.5 psi (0.03 bar, 3.45 kPa) maximum pressure each cycle and at maximum electrical load.

Electrical Rating: @ 60 Hz.

15 amp 125, 250, or 277 v AC

¼ hp 125 v AC, ½ Hp 250 VAC,

½ amp 125 v DC, ¼ amp 250 v DC.

0.5 VA @ 24 v AC, 50/60 Hz.

Contact Arrangement:

2 SPST-NC (manual reset).

Electrical Connections:

Screw top terminals with cup washers.

Conduit Opening: 7/8" diameter opening accepts ½" conduit.

Sample Line Connectors: Male, externally threaded 7/16" 24 UNS 2A thread, complete with nuts and self-aligning ferrules.

Sample Line Connections: Connectors will accept ¼" (6.35mm) OD rigid or semi-rigid tubing.

Approval and Recognition:

UL & CSA approved; CE pending.

Shipping Weight: 1.2 lbs.

Nominal Dimensions in Inches (Millimeters)

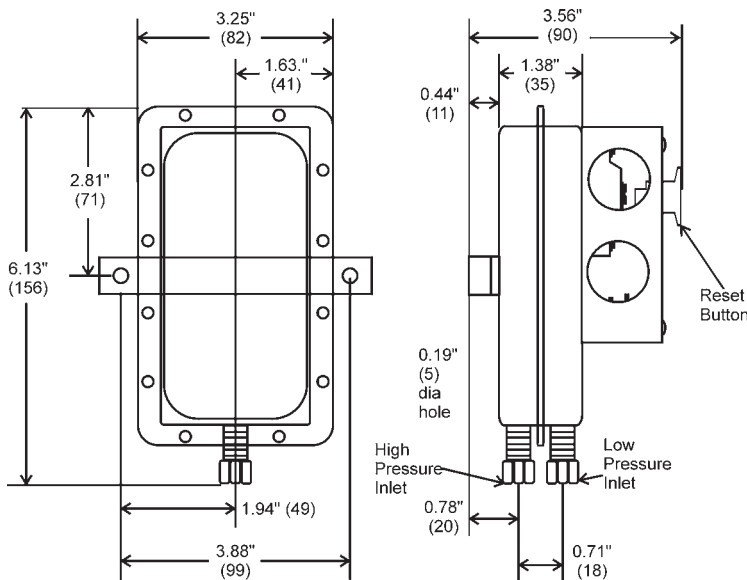

TABLE 1

Lead Switch A Set Point	Lag Switch B Set Point
1.25" - 3.00" w.c. (31.8 - 76.2 mm w.c.)	up to 5% after Switch A
3.00" - 6.00" w.c. (76.2 - 152.4 mm w.c.)	up to 10% after Switch A
6.00" - 9.00" w.c. (152.4 - 229 mm w.c.)	up to 15% after Switch A
9.00" - 12.00" w.c. (229 - 305 mm w.c.)	up to 35% after Switch A