

Setra Systems

DPT 264 Series Low Pressure Transducers and Transmitters

Installation Guide

1.0 GENERAL INFORMATION

Every Model DPT264 has been tested and calibrated before shipment. Specific performance specifications are shown on page 3 of this Guide.

Setra Systems DPT264 pressure transducers sense differential or gage (static) pressure and convert this pressure difference to a proportional high level analog output for both unidirectional and bi-directional pressure ranges. Two standard output versions are offered: A voltage output of 0 to 5 VDC or a current output of 4 to 20 mA.

2.0 MECHANICAL INSTALLATION

2.1 Media Compatibility

Model DPT264 transducers are designed to be used with air or non-conducting gases. **Use with liquids or corrosive gases will damage the unit.**

2.2 Environment

The operating temperature limits of the DPT264 are 0°F to +175°F (-18°C to +79°C)
The compensated temperature range is 0°F to +150°F (-18°C to +65°C).

2.3 Mounting

The DPT264 series is designed for mounting in either 2.75: snap-track or by using the four (4) slots (suitable for #6 screws) that are provided on the plate. Optimum performance is obtained by isolating the instrument from vibration and providing relatively clean, dry ambient air to the pressure ports.

Even though there is no flow through the DPT264, a filter is located in both the high and low-pressure ports for use in extreme dust or moisture conditions.

In most cases, preferred installation is with the baseplate mounted vertically and located on a relatively flat surface in a junction box or attached to a nearby beam. Easy field replacement is possible by removing the single case screw that holds the black sensor/circuit housing to the baseplate and lifting the black housing free. The baseplate remains mounted and can be used with the replacement unit's black sensor/circuit housing.

The axis most sensitive to vibration is the one perpendicular to the baseplate. Avoid mounting with maximum vibration along this axis.

2.4 Pressure Fittings

The Model DPT264 is designed to be used with 3/16" I.D. push-on tubing. Both the positive (high) pressure port and the reference (low) pressure port are located on the front of the unit, labeled "HIGH" and "LOW" respectively. For best results (shortest response time), 3/16" I.D. tubing is suggested for tubing lengths up to 100 feet long, 1/4" I.D. for tubing lengths up to 300 feet, and 3/8" I.D. for tubing lengths up to 900 feet.

3.0 ELECTRICAL INSTALLATION

If the Model DPT264 is supplied with the optional Conduit Enclosure, access the electrical terminations by removing the cover.

3.1 Voltage Output Units

The Model DPT264 voltage output is a 3-wire circuit, with three terminals available for wiring. These terminals have the designation COM, EXC, and OUT (see Diagram 1). The power supply and signal references are commoned on the circuit (see Diagram 2). The DPT264 voltage output can operate from 9-30 VDC excitation. The DPT264 has a 0-5 VDC output.

Voltage Circuit Diagram



Diagram 1

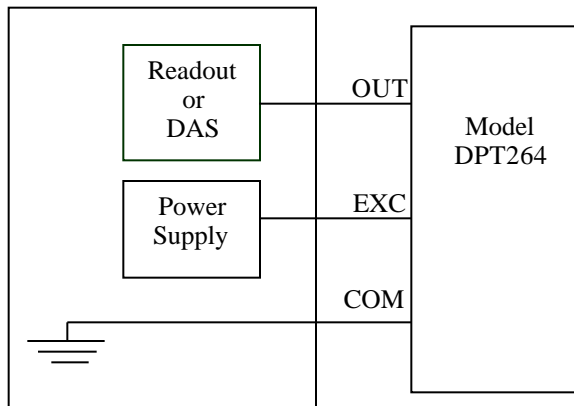

Diagram 2

- +EXC Connect to positive terminal of 9-30 VDC Power Supply
- +OUT Connect to positive terminal of Control or Pressure Monitor
- COM Connect as the reference for power supply and output signal

3.2 Current Output Units

The Model DPT264 is a two-wire loop-powered 4 to 20 mA current output unit and delivers rated current into any external load of 0 to 800 ohms. These terminals have the designation of + and – (see Diagram 3). The current flows into the + terminal and returns back to the power supply through the – terminal (see Diagram 4). The power supply must be a DC voltage source with a voltage range between 9 and 30 measured between the + and – terminals. The unit is calibrated at the factory with a 24 VDC loop supply voltage and a 250ohm load.

Current Circuit Diagram



Diagram 3

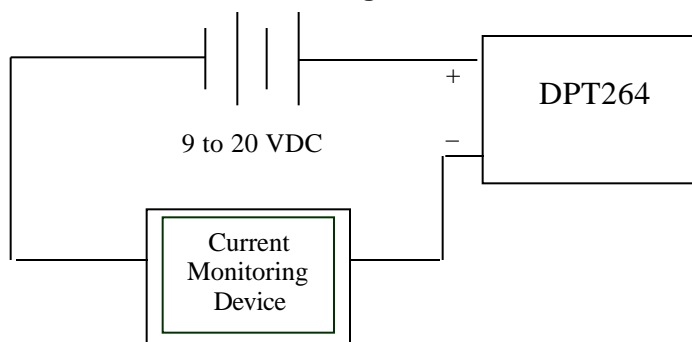

Diagram 4

4.0 CALIBRATION

The DPT264 transducer is factory calibrated and should require no field adjustment. Generally, the mounting position will have a zero effect on ranges below 1" WC. Whenever possible, any zero and/or span offsets should be corrected by software adjustment in the user's control system. However, both the zero and span adjustments are accessible either on the front of the unit or by removing the optional conduit enclosure. The DPT264 transducer is calibrated in the vertical position at the factory.

4.1 Voltage Output Zero Adjustment

While monitoring the voltage between the positive output (OUT) and common (COM), and with both pressure ports open to atmosphere, the zero may be adjusted by turning the zero adjustment screw (see Diagram 1 for location of the zero adjustment). For 0-5 VDC output units, the factory settings are 0.050 VDC (± 50 mV) for unidirectional pressure ranges and 2.5 VDC (± 50 mV) for bi-directional pressure ranges. Optional outputs are set at the same $\pm 1\%$ factory setting tolerance.

4.2 Voltage Output Span Adjustment (Complete the zero adjustment before setting span.)

Span or full-scale output adjustments should only be performed by using an accurate pressure standard (electronic manometer, digital pressure gauge, etc.) with at least comparable accuracy to the DPT264 transducer ($\pm 1\%$ full scale). With full range pressure applied to the high-pressure port (reference port open to atmosphere), the span may be adjusted by turning the SPAN adjustment screw. (See Diagram 1 for location of the SPAN adjustment.) For 0-5 VDC output units, the factory settings at full range pressure are 5.050 VDC (± 50 mV) for unidirectional and bi-directional ranges.

4.3 Current Output Zero Adjustment

While monitoring the current output between the + and – terminals, and with both pressure ports open to atmosphere, the zero may be adjusted by turning the zero adjustment screw. (See Diagram 3 for location of zero adjustment.) The factory settings are 4 mA (0.16mA) for unidirectional pressure ranges and 12 mA (0.16 mA) for bi-directional ranges.

4.4 Current Output Span Adjustment

Span of full-scale output adjustments should only be performed by using an accurate pressure standard (electronic manometer, digital pressure gauge, etc.) with at least comparable accuracy to the DPT264 transducer ($\pm 1\%$ FS). With full range pressure applied to the high-pressure port (reference port open to atmosphere), the span may be adjusted by turning the SPAN adjustment screw. (See Diagram 3 for location of SPAN adjustment.) The factory settings are 20 mA (0.16 mA) for unidirectional and bi-directional pressure ranges.

5.0 MODEL DPT264 PERFORMANCE SPECIFICATIONS

Accuracy* (at Constant temperature)	$\pm 1.0\%$ FS	<u>Thermal Effects</u>	
Non-Linearity, BFSL	$\pm 0.96\%$ FS	Compensated Range °F (°C)	0 to +150 (-18 to +65)
Hysteresis	0.2% FS	Zero/Span Shift %FS/°F(°C)	0.033 (0.06)
Non-Repeatability	0.1% FS	Maximum Line Pressure	10 psi
		Overpressure	10 psi in positive or negative direction
*RSS of Non-Linearity, Non-Repeatability and Hysteresis			
<u>Position Effects</u>			
(Unit is factory calibrated at 0g effect in the vertical Position)			
Range	Zero Offset (%FS/G)		
0 to 0.1 in. WC	2.1		
0 to 1.0 in. WC	0.22		
0 to 5 in. WC	0.14		
0 to 10 in. WC	0.1`2		

RETURNING PRODUCTS FOR REPAIR

Please contact Setra (800-257-3872, 978-263-1400) before returning unit for repair to review information relative to your application. Many times only minor field adjustments may be necessary.

When returning a product to Setra, the material should be carefully packaged and shipped prepaid to:

Setra Systems, Inc.
159 Swanson Road
Boxborough, MA 01719
Attn: Repair Department

To assure prompt handling, please supply the following information and include it inside the package of returned material:

1. Name and phone number of person to contact.
2. Shipping and billing instructions.
3. Full description of the malfunction
4. Identify any hazardous material used with product.

Notes: Please remove any pressure fittings and plumbing that you have installed and enclose any required mating electrical connectors and wiring diagrams.

Allow approximately 3 weeks after receipt at Setra for the repair and return of the unit. Non-warranty repairs will not be made without customer approval and a purchase order to cover repair charges.

Calibration Services

Setra maintains a complete calibration facility that is traceable to the National Institute of Standards & Technology (NIST). If you would like to re-calibrate or rectify your Setra pressure transducers or transmitters, please call our Repair Department at 800-257-3872 (978-263-1400) for scheduling, cost and turnaround estimates.

MODEL DPT264 PRESSURE PRODUCTS WARRANTY AND LIMITATION OF LIABILITY

SETRA warrants its Model DPT264 and CDPT264 products to the original consumer purchaser against defects for a period of three years from the date of sale by SETRA, as shown in its shipping documents.

Without charge, SETRA will repair or replace products found to be defective within the warranty period.

The serial number or date code must not have been removed, defaced or otherwise changed.

SETRA must be notified in advance of any returns; any products returned to SETRA must be transportation prepaid.

The foregoing warranty is in lieu of all warranties, express, implied or statutory, including but not limited to, any implied warranty of merchantability for a particular purpose.

SETRA's liability for breach of warranty is limited to repair or replacement, or if the goods cannot be repaired or replaced, to a refund of the purchase price. SETRA's liability for all other breaches is limited to a refund of the purchase price. In no instance shall SETRA be liable for incidental or consequential damages arising from a breach of warranty, or from the use or installation of its products.

No representative or person is authorized to give any warranty other than as set out above or to assume for SETRA any other liability in connection with the sale of its products.