



**ITT**

**Bell & Gossett®**  
Parts List HS-300C-PL

# service PARTS

c a t a l o g



**CIRCULATORS &  
CENTRIFUGAL PUMPS**



**HYDRONIC SPECIALTIES**



**ENGINEERED SPECIALTIES**

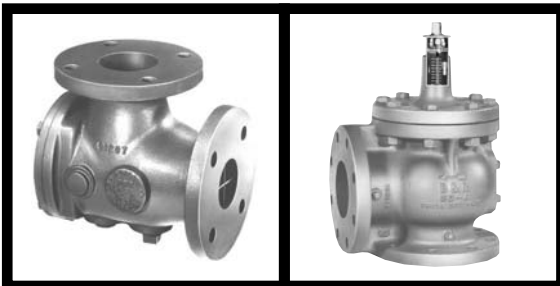

**CENTRIFUGAL PUMP  
ACCESSORIES**



# TABLE OF CONTENTS

| <b><u>CIRCULATORS &amp; PUMPS</u></b>                            | <b><u>PAGE</u></b> | <b><u>HYDRONIC SPECIALTIES</u></b>   | <b><u>PAGE</u></b> |
|--|--------------------|--|--------------------|
| Circulator Exploded View.....                                    | 3                  | How to Select Parts for Hydronic Specialties or<br>Engineered Specialties.....   | 36                 |
| Series 60 Maintenance Free Exploded View.....                    | 4                  | Flo-Control™ Valves.....   | 37                 |
| Series PD & Series 60 Exploded View.....                         | 5                  | Pressure Reducing & Dual Unit Valves.....  | 38                 |
| Series 1522 Exploded View.....                                   | 6                  | Comfort-Trol® & Modumate Zone Valves.....  | 39                 |
| Exploded Views of Bearing Assemblies.....                        | 7                  | Enhanced Air Separators.....   | 40                 |
| How to Select Parts for Circulators & Pumps.....                 | 8                  | 107A Air Vent.....   | 41                 |
| Little Red®.....   | 9                  |  |                    |
| Series PL™.....  | 9                  |  |                    |
| Series 100®.....   | 10                 | <b><u>ENGINEERED SPECIALTIES</u></b>   |                    |
| Series HV and 2".....  | 11                 | Bladder Tanks.....   | 41                 |
| Series PR, 2½", LD-3 and HD-3.....                               | 12                 | Thermoflo® Balancer.....   | 42                 |
| Obsolete Circulator Models 1", 1¼", 1½"<br>2" and HV.....        | 13                 | Thermoflo® Indicator.....  | 43                 |
| Obsolete Circulator Models 1½" & HV.....                         | 14                 | Circuit Setter® Balance Valve Exploded Views.....  | 44                 |
| Series PD.....   | 15                 | Circuit Setter® Ball Style Valves.....   | 45                 |
| How to Select Parts for Maintenance Free<br>Series 60 Pumps..... | 16                 | Circuit Setter® Globe Style Valves.....  | 46                 |
| Standard Size Designations.....                                  | 17                 |  |                    |
| Sizes 1x1x5¼ and 1¼x1¼x5¼.....                                   | 18                 | <b><u>CENTRIFUGAL PUMP ACCESSORIES</u></b>   |                    |
| Sizes 1½x1½x5¼ and 2x2x5¼.....                                   | 19                 | How to Select Parts for Centrifugal Pump<br>Accessories.....   | 47                 |
| Size 3x3x5¼.....   | 20                 | Triple Duty® Valves:   |                    |
| Sizes 1½x1½x6¼ and 2x2x6¼.....                                   | 21                 | Model 3DX.....   | 48                 |
| Sizes 1½x1½x7 and 2x2x7.....                                     | 22                 | Models with Grooved Connections.....   | 49                 |
| Maintenance Free Series 60 Couplers.....                         | 23                 | Angle Pattern Models.....  | 50                 |
| How to Select Parts for Series 60 or<br>Series 1522 Pumps.....   | 24                 | Straight Pattern Models.....   | 51                 |
| Series 60 Sleeve Bearing Pumps:                                  |                    | Reduced Port Models.....   | 52                 |
| Standard Size Designations.....                                  | 25                 | Suction Diffusers.....   | 53                 |
| Sizes 1AA and 1¼AA.....  | 26                 |  |                    |
| Sizes 1½AA and 2AA.....  | 27                 | Circulator Replacement Parts   |                    |
| Sizes 1½A and 2A.....  | 28                 | "Where Used" List.....   | 54                 |
| Size 2½F.....  | 29                 |  |                    |
| Power Pack Selection.....  | 30                 | Hydronic Specialties, Engineered Specialties &<br>Centrifugal Pump Accessories Replacement<br>Parts "Where Used" List..... | 62                 |
| Bearing Assembly Selection.....                                  | 31                 |  |                    |
| Series 1522 Pumps:   |                    | Troubleshooting Hydronic Systems.....  | 70                 |
| Standard Size Designations.....                                  | 32                 |  |                    |
| Sizes ¾AAB and 1AAB.....   | 33                 |  |                    |
| Sizes 1¼AAB and 1½AAB.....                                       | 34                 |  |                    |
| Seal Selection Chart.....  | 35                 |  |                    |

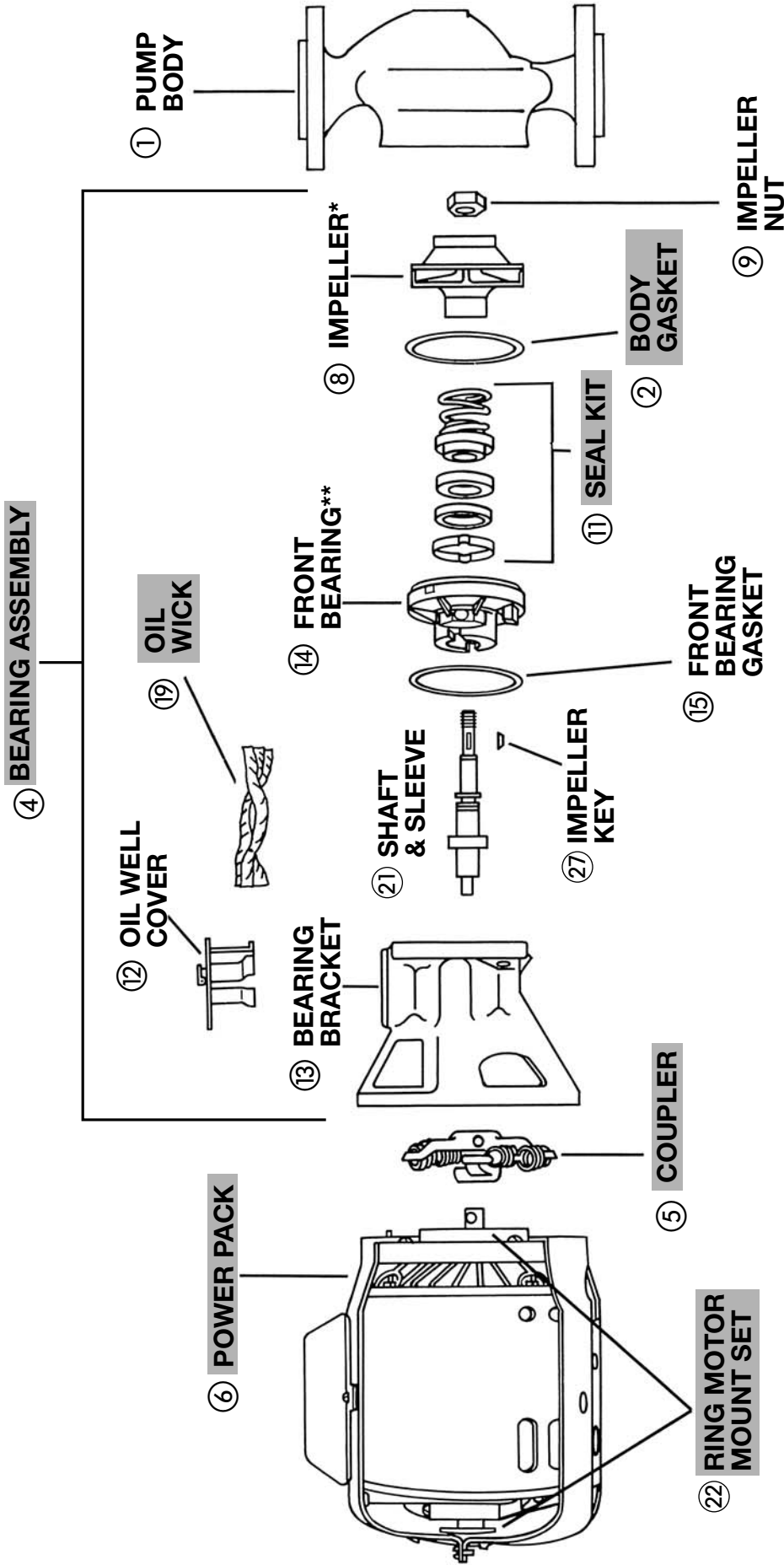

# Circulator

Exploded View  
 For Series 100, Series HV, 2",  
 PR, 2 1/2", LD-3 & HD-3 Models

\*Impeller not always included in Bearing Assembly.

\*\*Shown rotated 90°.

■ – Factory recommended spare parts.

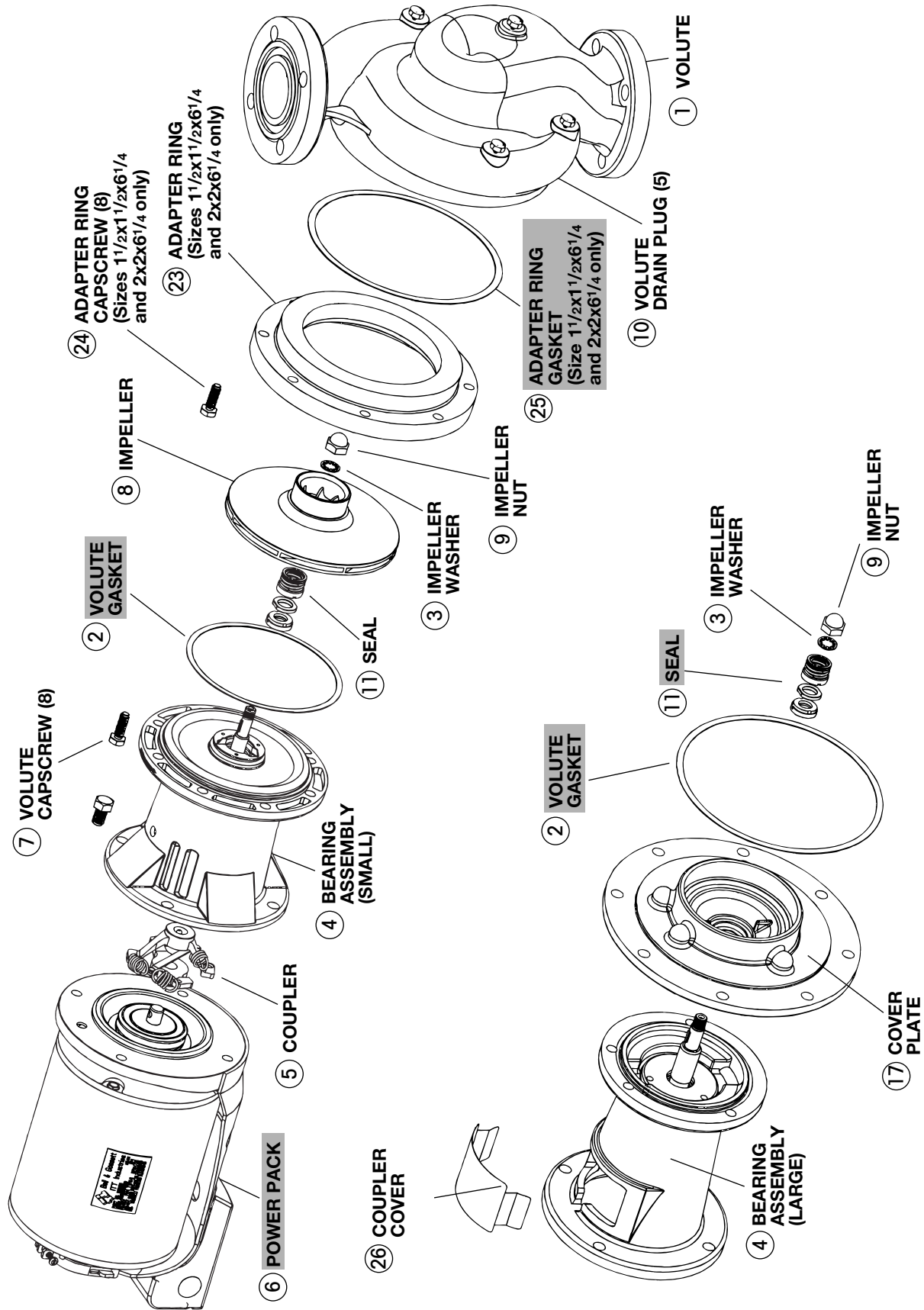

# Series 60 Maintenance Free Pump

Exploded View

■ - Factory recommended spare parts.

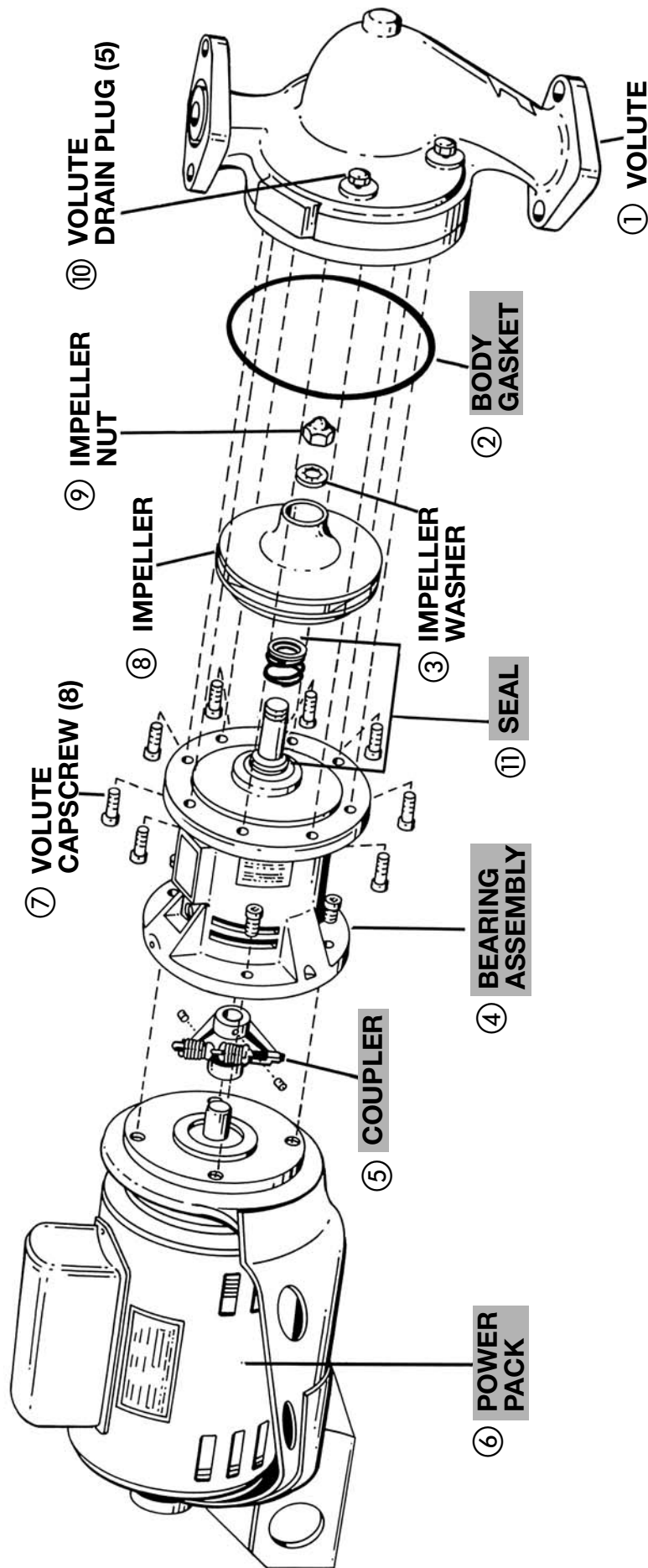

## Series PD & Series 60 – Sleeve Bearing Pumps

Exploded View

■ – Factory recommended spare parts.

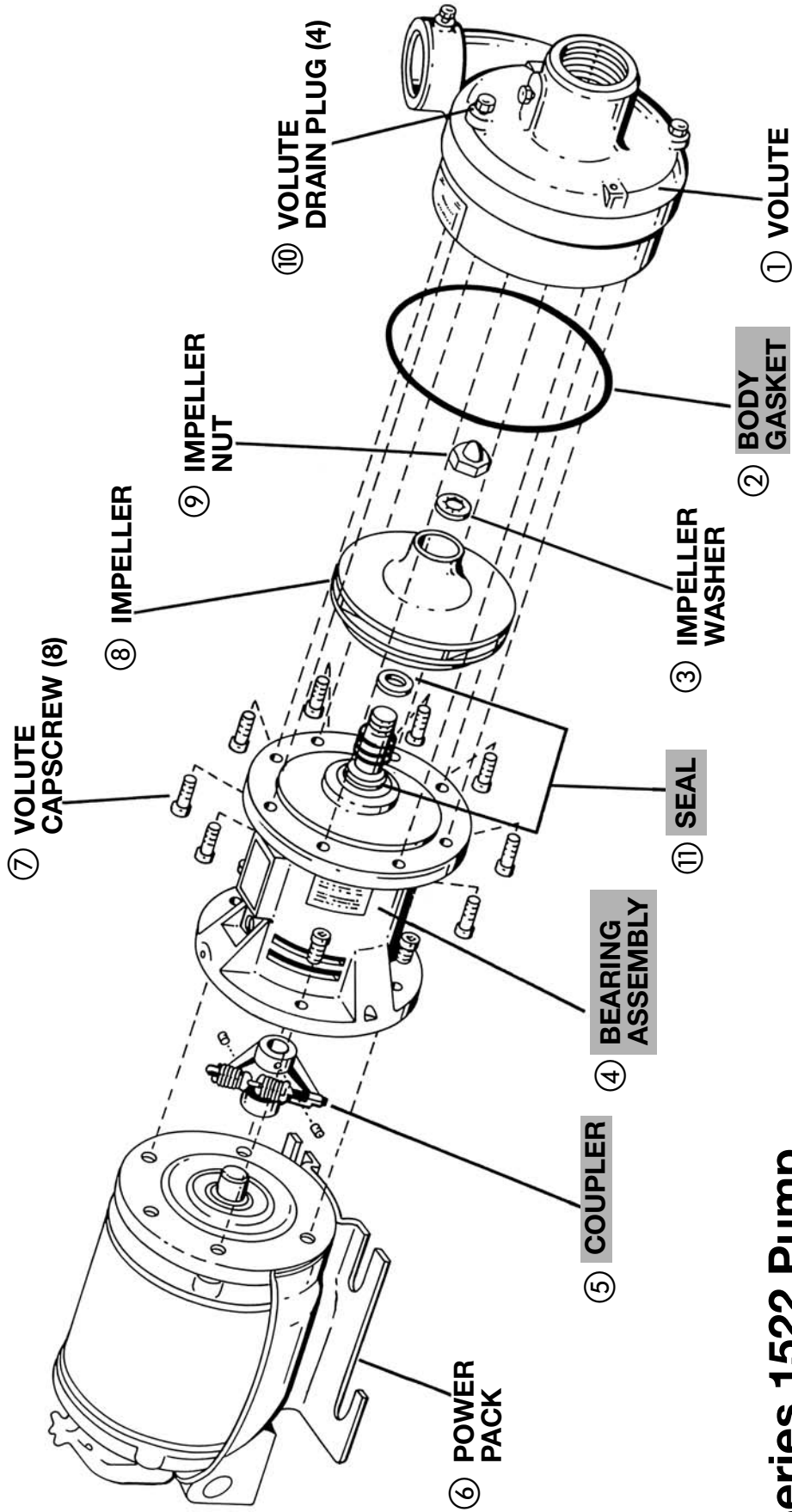

# Series 1522 Pump

Exploded View

■ - Factory recommended spare parts.

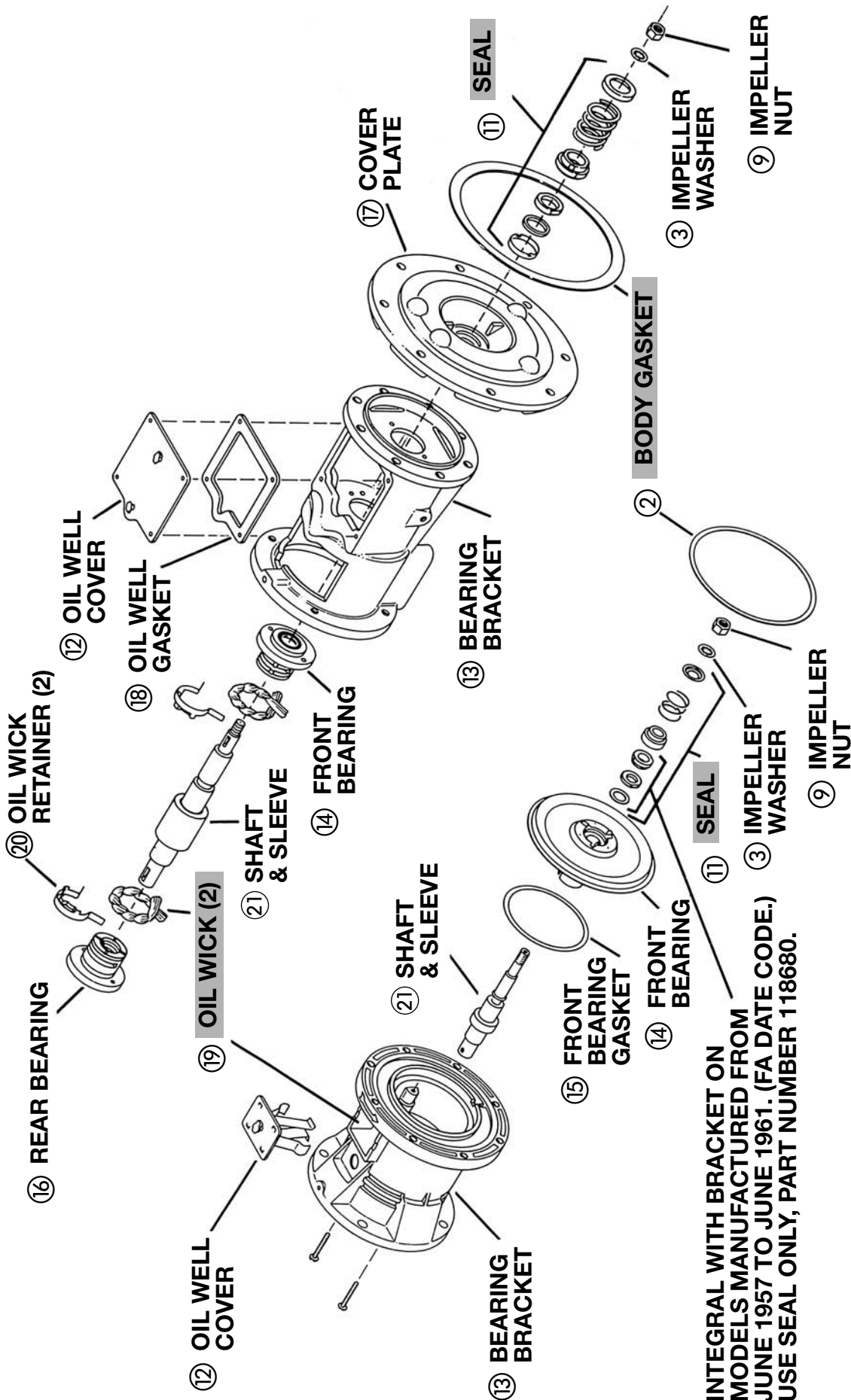

INTEGRAL WITH BRACKET ON MODELS MANUFACTURED FROM JUNE 1957 TO JUNE 1961. (FA DATE CODE.) USE SEAL ONLY, PART NUMBER 118680.

PD 35 & 37, SERIES 60 "AA" & SERIES 1522

PD 38, 39 & 40 SERIES 60 "A" & SERIES 60 2 1/2 F

# Series PD, Series 60 – Sleeve Bearing & Series 1522 Bearing Assemblies

Exploded View

– Factory recommended spare parts.

NOTE: Use liquid sealant in place of bearing gaskets on PD38, PD39 & PD40 pumps.

# How to Select Parts for Circulators & Pumps on Pages 9-15

The pump nameplate identifies the pump by the series and the six digit part number as shown in the example below.



The nameplate above identifies the pump as a Series HV, part number 102210. The date code shows the date of manufacture as October, 1990 as explained in the chart below. The nameplate identifies the booster pump for future reference. **DO NOT REMOVE THE NAME-PLATE.** It is important when ordering replacement parts to furnish complete nameplate data.

To ensure the correct parts will be selected, follow the procedure below:

1. Determine from the nameplate the pump series, pump construction (if applicable) and the six digit part number.
2. Determine the date the unit was manufactured. See chart below.
3. Refer to the index for the page number of the parts breakdown for the specific booster pump series.
4. Find the proper column in the parts breakdown for the pump involved. Be sure to use the date codes on top of each column where applicable.
5. Select part numbers using the applicable drawings on pages 3, 5 & 7 for identification.
6. When ordering a replacement motor or motor components, always furnish complete motor nameplate data.

| DATE OF MANUFACTURE CODE  |           |   |  |   |           |   |      |   |           |    |      |
|---|-----------|---|--|---|-----------|---|------|---|-----------|----|------|
| The date code is made up of two or three characters depending upon the year.                    |           |   |  |   |           |   |      |   |           |    |      |
| 1946-1960<br>The number denotes the month. The last character is a letter and denotes the year. |           |   | 1961-82<br>Two characters. First letter is month. Second letter is year. |   |           | 1983-<br>Three characters. The letter denotes the month. The numbers denote the year. |      |   |           |    |      |
| 1   | January   | G | 1946   | A | January   | A   | 1961 | A | January   | 78 | 1987 |
| 2   | February  | H | 1947   | B | February  | B   | 1962 | B | February  | 88 | 1988 |
| 3   | March     | J | 1948   | C | March     | C   | 1963 | C | March     | 98 | 1989 |
| 4   | April     | K | 1949   | D | April     | D   | 1964 | D | April     | 09 | 1990 |
| 5   | May       | L | 1950   | E | May       | E   | 1965 | E | May       | 19 | 1991 |
| 6   | June      | M | 1951   | F | June      | F   | 1966 | F | June      | 29 | 1992 |
| 7   | July      | N | 1952   | G | July      | G   | 1967 | G | July      | 39 | 1993 |
| 8   | August    | P | 1953   | H | August    | H   | 1968 | H | August    | 49 | 1994 |
| 9   | September | R | 1954   | J | September | J   | 1969 | J | September | 59 | 1995 |
| 10  | October   | T | 1955   | K | October   | K   | 1970 | K | October   | 69 | 1996 |
| 11  | November  | U | 1956   | L | November  | L   | 1971 | L | November  | 79 | 1997 |
| 12  | December  | V | 1957   | M | December  | M   | 1972 | M | December  | 89 | 1998 |
|   |           | W | 1958   |   |           | N   | 1973 |   |           | 99 | 1999 |
|   |           | X | 1959   |   |           | P   | 1974 |   |           | 00 | 2000 |
|   |           | Y | 1960   |   |           | R   | 1975 |   |           | 10 | 2001 |
|   |           |   |  |   |           | T   | 1976 |   |           | 20 | 2002 |
|   |           |   |  |   |           | U   | 1977 |   |           | 30 | 2003 |
|   |           |   |  |   |           | V   | 1978 |   |           | 40 | 2004 |
|   |           |   |  |   |           | W   | 1979 |   |           | 50 | 2005 |
|   |           |   |  |   |           | X   | 1980 |   |           | 60 | 2006 |
|   |           |   |  |   |           | Y   | 1981 |   |           | 70 | 2007 |
|   |           |   |  |   |           | Z   | 1982 |   |           | 80 | 2008 |
|   |           |   |  |   |           |   |      |   |           | 90 | 2009 |



# PARTS FOR LITTLE RED & SERIES PL CIRCULATORS

## LITTLE RED

| ITEM NO. | DESCRIPTION  | MODEL LR-20BF | MODEL LR-20B | MODEL LR-12 & LR-12BF | MODEL LR-12B | MODEL LR-15B |
|----------|--|---------------|--------------|-----------------------|--------------|--------------|
|          | Body   | N/A           | N/A          | N/A                   | N/A          | N/A          |
|          | Impeller   | P15627        | P15627       | P15629                | P15629       | P15627       |
|          | Capacitor 115V   | N/A           | N/A          | M15784                | M15784       | M15784       |
|          | Capacitor 110V   | N/A           | N/A          | N/A                   | N/A          | N/A          |
|          | Capacitor 220V   | N/A           | N/A          | M15784                | M15784       | M15788       |
|          | Flange Gasket Set-Ring Type 1 <sup>13</sup> / <sub>16</sub> " ID (2 Req'd) | 118368        | N/A          | 118368                | N/A          | N/A          |
|          | Fastener Pack For Above*   | P64910        | N/A          | P64910                | N/A          | N/A          |
|          | Flange Gasket – Ring Type 1 <sup>5</sup> / <sub>16</sub> " ID (2 Req'd)    | P15692        | P15692       | P15692                | P15692       | P15692       |
|          | Fastener Pack for Above*   | P15696        | P15696       | P15696                | P15696       | P15696       |
|          | Flange (3/4")  | P00739        | P00789       | P00739                | P00789       | P00789       |
|          | Flange (1")  | P00792        | P00836       | P00792                | P00836       | P00836       |
|          | Flange (1 <sup>1</sup> / <sub>4</sub> ")                                   | P03250        | P00837       | P03250                | P00837       | P00837       |
|          | Flange (1 <sup>1</sup> / <sub>2</sub> ")                                   | P03430        | P00779       | P03430                | P00779       | P00779       |
| 24       | Seal Repair Kit Consisting of:   | N/A           | N/A          | N/A                   | N/A          | N/A          |
| 25       | Seal & Cushion Assembly  | N/A           | N/A          | N/A                   | N/A          | N/A          |
| 26       | Seat Cup   | P15683        | P15683       | P15683                | P15683       | P15683       |
| 27       | Ceramic Insert   | P70712        | P70712       | P70712                | P70712       | P70712       |
| 9        | Impeller Nut   | P15697        | P15697       | P15697                | P15697       | P15697       |
| 28       | Impeller Tube  | P15698        | P15698       | P15698                | P15698       | P15698       |
| 29       | Oil Tube   | P15775        | P15775       | P15775                | P15775       | P15775       |
| 2        | Body Gasket  | P15691        | P15691       | P15691                | P15691       | P15691       |
| 30       | Assembly Tool  | P15210        | P15210       | P15210                | P15210       | P15210       |

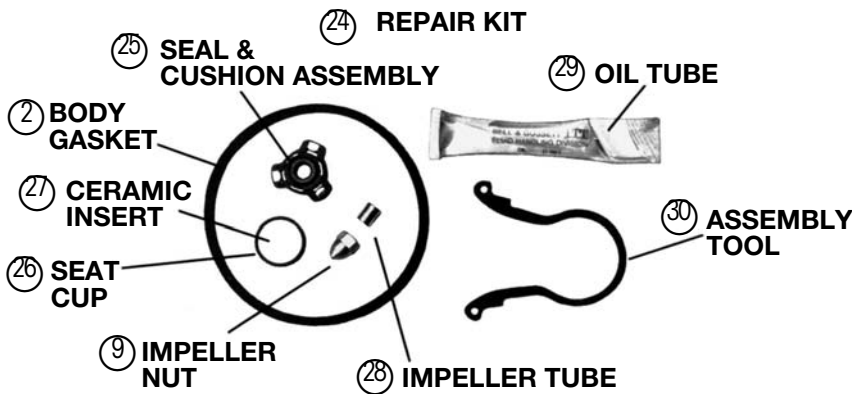

### RING GASKETS

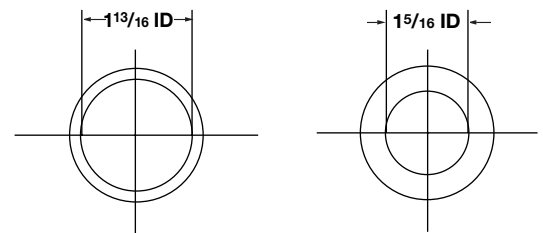

## SERIES PL

| DESCRIPTION                              | CAST IRON MODELS (PART NUMBER) |                |                |                |                |                |                   |                   | BRONZE MODELS (PART NUMBER) |                 |                 |                 |                 |                 |                    |                    |
|--|--------------------------------|----------------|----------------|----------------|----------------|----------------|-------------------|-------------------|-----------------------------|-----------------|-----------------|-----------------|-----------------|-----------------|--------------------|--------------------|
|  | PL-30 (1BL012)                 | PL-36 (1BL001) | PL-45 (1BL002) | PL-50 (1BL016) | PL-55 (1BL032) | PL-75 (1BL034) | PL-130/2 (1BL063) | PL-130/3 (1BL070) | PL-30B (1BL013)             | PL-36B (1BL003) | PL-45B (1BL004) | PL-50B (1BL017) | PL-55B (1BL068) | PL-75B (1BL035) | PL-130B/2 (1BL065) | PL-130B/3 (1BL072) |
| Seal Kit                                 | 189144                         |                |                | 189577         | 189144         | 189174         |                   | 189144            |                             |                 | 189577          | 189144          | 189174          |                 |                    |                    |
| Body Gasket                              | P15691                         |                |                | P83025         | P13691         |                |                   | P15691            |                             |                 | P83025          | P15691          |                 |                 |                    |                    |
| Impeller                                 | 189170                         | 189171         | 189169         | 189172         | 189169         | 189173         |                   | 189170            | 189171                      | 189169          | 189172          | 189169          | 189173          |                 |                    |                    |
| Fastener Package*                        | P64910                         | P64940         |                | P83031         | P65031         |                | P09540            | P64910            | P64940                      |                 | P83031          | P65031          |                 | P09540          |                    |                    |
| Flange Gasket Set                        | 118368                         | 118373         |                | 118368         | 118378         |                | 118129            | 118368            | 118373                      |                 | 118368          | 118378          |                 | 118129          |                    |                    |
| Flanges                                  | CAST IRON                      |                |                |                |                |                |                   |                   | BRONZE                      |                 |                 |                 |                 |                 |                    |                    |
| Flange (3/4")                            | P00739                         | NONE           |                | P00739         | NONE           |                |                   | P00789            | NONE                        |                 | P00789          | NONE            |                 |                 |                    |                    |
| Flange (1")                              | P00792                         | P00802         |                | P00792         | NONE           |                |                   | P00836            | P00804                      |                 | P00836          | NONE            |                 |                 |                    |                    |
| Flange (1 <sup>1</sup> / <sub>4</sub> ") | P03250                         | P03300         |                | P03250         | NONE           |                |                   | P00837            | P06660                      |                 | P00837          | NONE            |                 |                 |                    |                    |
| Flange (1 <sup>1</sup> / <sub>2</sub> ") | P03430                         | P03410         |                | P03430         | NONE           |                |                   | P00779            | P06690                      |                 | P00779          | NONE            |                 |                 |                    |                    |
| Flange (2")                              | NONE                           |                |                | F14200         |                | NONE           |                   | NONE              |                             |                 | F54200          |                 | NONE            |                 |                    |                    |
| Flange (2 <sup>1</sup> / <sub>2</sub> ") | NONE                           |                |                | NONE           |                | P03560         |                   | NONE              |                             |                 | NONE            |                 | P06750          |                 |                    |                    |
| Flange (3")                              | NONE                           |                |                | NONE           |                | F74000         |                   | NONE              |                             |                 | NONE            |                 | F74800          |                 |                    |                    |

\*Includes flange gaskets. N/A - Not Available ■ - Factory recommended spare part.

# PARTS FOR SERIES 100

## MODELS MANUFACTURED AFTER NOVEMBER, 1956 ("11U" DATE CODE)

| ITEM NO. | DESCRIPTION                          | 100 NFI<br>106189   | 100 BI<br>106190    | 100 AB<br>106192 | 100 BNFI<br>106197 |
|----------|--------------------------------------|---------------------|---------------------|------------------|--------------------|
| 1        | Body                                 | 118339              | 118339              | 118413           | 118413             |
|          | Body Capscrew (4 required)           | P40020              | P40020              | P40020           | P40020             |
| 4        | Bearing Assembly                     | 118844 <sup>1</sup> | 118844 <sup>1</sup> | 189034           | 189034             |
| 4 & 8    | Bearing Assembly with NFI Impeller   | 189134 <sup>2</sup> | NONE                | NONE             | 189161             |
|          | Bracket Capscrew ( 4 required)       | P04770              | P04770              | P04770           | P04770             |
| 8        | Impeller                             | 189132              | 118431              | 118431           | 189132             |
| 5        | Coupler Assembly                     | 118705+             | 118705+             | 118705+          | 118705+            |
|          | Flange (¾")                          | P00739              | P00739              | P00789           | P00789             |
|          | Flange (1")                          | P00792              | P00792              | P00836           | P00836             |
|          | Flange (1¼")                         | P03250              | P03250              | P00837           | P00837             |
|          | Flange (1½")                         | P03430              | P03430              | P00779           | P00779             |
|          | Flange Gasket Set                    | 118368              | 118368              | 118368           | 118368             |
|          | Fastener Package with Flange Gaskets | P64910              | P64910              | P64910           | P64910             |
| 6        | Power Pack                           | 111034*             | 111034*             | 111034*          | 111034*            |
| 22       | Ring Motor Mount Set                 | 118223              | 118223              | 118223           | 118223             |
| 5 & 22   | Coupler & Ring Mount Set             | 118706              | 118706              | 118706           | 118706             |

+Cast iron type. For stamped steel, use 189110.

\*115V only. For 230V, use 111035.

### Note:

#75 Circulator is a Series 100 w/ ¾" flanges.

#100 Circulator is a Series 100 w/ 1" flanges.

#125 Circulator is a Series 100 w/ 1¼" flanges.

#150 Circulator is a Series 100 w/ 1½" flanges.

## BEARING ASSEMBLIES

| ITEM NO. | DESCRIPTION          | 118844 <sup>1</sup> | 189134 <sup>2</sup> | 189034 | 189161 |
|----------|----------------------|---------------------|---------------------|--------|--------|
| 13       | Bearing Bracket      | P77119              | P77119              | P77119 | P77119 |
| 2        | Body Gasket          | P04080              | P04080              | P04080 | P04080 |
| 14       | Front Bearing        | 189071              | 189071              | 189071 | 189071 |
| 15       | Front Bearing Gasket | P80815              | P80815              | P80815 | P80815 |
| 27       | Impeller Key         | P04940              | P04940              | P04940 | P04940 |
|          | Impeller Gasket      | P57000              | P57000              | P57000 | P57000 |
| 9        | Impeller Nut         | P44200              | P44200              | P44200 | P44200 |
| 12       | Oil Well Cover       | P81238              | P81238              | P81238 | P81238 |
| 19       | Oil Wick Set         | 118395              | 118395              | 118395 | 118395 |
| 11       | Seal Kit**           | 118681              | 118681              | 118681 | 118681 |
| 21       | Shaft & Sleeve       | 189035              | 189035              | 189035 | 189035 |
| 8        | Impeller (NFI)       | NONE                | 189132              | NONE   | 189132 |

- Factory recommended spare part.

<sup>1</sup> May be used in place of 189034 if manufactured after 2004 (date code "40").

<sup>2</sup> May be used in place of 189161 if manufactured after 2004 (date code "40").

\*\*For Built-To-Order pumps, see the seal selection chart on page 35.

**NOTE:** Refer to page 3 for exploded view of typical circulator.

# PARTS FOR SERIES HV & 2"

## SERIES HV MANUFACTURED AFTER JANUARY, 1976 ("AT" DATE CODE)

| ITEM NO. | DESCRIPTION                          | HV NFI<br>102210 | HV BI<br>102230 | HV AB<br>102231 | HV BNFI<br>102213 |
|----------|--------------------------------------|------------------|-----------------|-----------------|-------------------|
| 1        | Body                                 | 189124           | 189124          | 189125          | 189125            |
|          | Body Capscrew (4 required)           | P03470           | P03470          | P03470          | P03470            |
| 4        | Bearing Assembly                     | 189165           | 189165          | 189165          | 189165            |
| 4 & 8    | Bearing Assembly with Impeller       | 189166           | NONE            | NONE            | 189166            |
| 8        | Impeller                             | 189128           | P07792          | P07792          | 189128            |
| 5        | Coupler Assembly                     | 118705+          | 118705+         | 118705+         | 118705+           |
|          | Flange (1")                          | P00802           | P00802          | P00804          | P00804            |
|          | Flange (1¼")                         | P03300           | P03300          | P06660          | P06660            |
|          | Flange (1½")                         | P03410           | P03410          | P06690          | P06690            |
|          | Flange Gasket Set                    | 118373           | 118373          | 118373          | 118373            |
|          | Fastener Package with Flange Gaskets | P64940           | P64940          | P64940          | P64940            |
| 6        | Power Pack                           | 111061           | 111061          | 111061          | 111061            |
| 22       | Ring Motor Mount Set                 | 118223           | 118223          | 118223          | 118223            |
| 5 & 22   | Coupler & Ring Mount Set             | 118706           | 118706          | 118706          | 118706            |

## 2" MODELS MANUFACTURED AFTER JANUARY, 1976 ("AT" DATE CODE)

| ITEM NO. | DESCRIPTION                         | 2" NFI<br>102214 | 2" BI<br>102232 | 2" AB<br>102233 | 2" BNFI<br>102217 |
|----------|-------------------------------------|------------------|-----------------|-----------------|-------------------|
| 1        | Body                                | 189126           | 189126          | 189127          | 189127            |
|          | Body Capscrew (4 required)          | P03470           | P03470          | P03470          | P03470            |
| 4        | Bearing Assembly                    | 189165           | 189165          | 189165          | 189165            |
| 4 & 8    | Bearing Assembly with Impeller      | 189166           | N/A             | N/A             | 189166            |
| 8        | Impeller                            | 189128           | P07792          | P07792          | 189128            |
| 5        | Coupler Assembly                    | 118705+          | 118705+         | 118705+         | 118705+           |
|          | Flange (2")                         | F14200           | F14200          | F54200          | F54200            |
|          | Flange Gasket Set                   | 118378           | 118378          | 118378          | 118378            |
|          | Fastener Package with Flange Gasket | P65031           | P65031          | P65030          | P65030            |
| 6        | Power Pack                          | 111061           | 111061          | 111061          | 111061            |
| 22       | Ring Motor Mount Set                | 118223           | 118223          | 118223          | 118223            |
| 5 & 22   | Coupler & Ring Mount Set            | 118706           | 118706          | 118706          | 118706            |

## BEARING ASSEMBLIES

| ITEM NO. | DESCRIPTION          | 189165** | 189166*** |
|----------|----------------------|----------|-----------|
| 13       | Bearing Bracket      | P77139   | P77139    |
| 2        | Body Gasket          | P04890   | P04890    |
| 14       | Front Bearing        | P77308   | P77308    |
| 15       | Front Bearing Gasket | P80816   | P80816    |
| 27       | Impeller Key         | P04940   | P04940    |
|          | Impeller Gasket      | NONE     | P57000    |
| 9        | Impeller Nut         | P44200   | P44200    |
| 12       | Oil Well Cover       | P81239   | P81239    |
| 19       | Oil Wick Set         | 118395   | 118395    |
| 11       | Seal Kit*            | 118681   | 118681    |
| 21       | Shaft & Sleeve       | 189035   | 189035    |
| 8        | Impeller             | NONE     | 189128    |

- Factory recommended spare part.

\*For Built-To-Order pumps, see the seal selection chart on page 35.

\*\*Use the same replacement parts for obsolete bearing assemblies 189120 or 189122.

\*\*\*Use the same replacement parts for obsolete bearing assembly 189136.

+Cast iron type. For stamped steel, use 189110.

N/A - Not Available.

**NOTE:** Refer to page 3 for exploded view of typical circulator.

# PARTS FOR SERIES PR, 2-1/2", LD-3 & HD-3

## SERIES PR, 2-1/2", LD-3 & HD-3 MANUFACTURED AFTER 1950

| ITEM NO. | DESCRIPTION                        | PR  | 2-1/2"                                    | LD-3                                      | HD-3                                      |
|----------|------------------------------------|---|---|---|---|
|          |                                    | 102206 (IB)<br>102207 (BI)<br>102208 (AB) | 102218 (IB)<br>102219 (BI)<br>102220 (AB) | 102222 (IB)<br>102223 (BI)<br>102224 (AB) | 102226 (IB)<br>102227 (BI)<br>102228 (AB) |
| 1        | Body (Cast Iron)                   | 118637                                    | 118644                                    | 118644                                    | 118644                                    |
| 1        | Body (Brass)                       | P00240                                    | P07610                                    | P07610                                    | P07610                                    |
|          | Body Capscrew (4 required)         | P03470                                    | P03470                                    | P03470                                    | P03470                                    |
| 4        | Bearing Assembly                   | 189105                                    | 189105                                    | 189105                                    | 189105                                    |
| 8        | Impeller (Steel)                   | 118830                                    | 118676                                    | 118676                                    | 118675                                    |
| 8        | Impeller (Brass)                   | 118612                                    | 118440                                    | 118440                                    | 118439                                    |
| 5        | Coupler Assembly                   | 118705+                                   | 118723                                    | 118723                                    | 118723                                    |
|          | Flange (Steel)                     | -   | P03560                                    | F74000                                    | F74000                                    |
|          | Flange (Brass)                     | -   | P06750                                    | F74800                                    | F74800                                    |
|          | Flange for PR Only (Steel, 3/4")   | P00739                                    | -   | -   | -   |
|          | Flange for PR Only (Brass, 3/4")   | P00789                                    | -   | -   | -   |
|          | Flange for PR Only (Steel, 1")     | P00792                                    | -   | -   | -   |
|          | Flange for PR Only (Brass, 1")     | P00836                                    | -   | -   | -   |
|          | Flange for PR Only (Steel, 1 1/4") | P03250                                    | -   | -   | -   |
|          | Flange for PR Only (Brass, 1 1/4") | P00837                                    | -   | -   | -   |
|          | Flange for PR Only (Steel, 1-1/2") | P03430                                    | -   | -   | -   |
|          | Flange for PR Only (Brass, 1-1/2") | P00779                                    | -   | -   | -   |
|          | Flange Gasket Set                  | 118368                                    | 118129                                    | 118129                                    | 118129                                    |
|          | Fastener Package                   | P64910 ▼                                  | P65130                                    | P65130                                    | P65130                                    |
| 6        | Power Pack - Sleeve Bearing        | 111031**                                  | 111040***                                 | 111040***                                 | 111042                                    |
| 6        | Power Pack - Ball Bearing          | NONE                                      | 169239 ▲                                  | 169239 ▲                                  | 169240 ▲                                  |
| 22       | Ring Motor Mount Set               | 118223                                    | 118228                                    | 118228                                    | 118228                                    |
| 5 & 22   | Coupler & Ring Mount Set           | 118706                                    | 118724                                    | 118724                                    | 118724                                    |

## BEARING ASSEMBLY

| ITEM NO. | DESCRIPTION          | 189105              |
|----------|----------------------|---------------------|
| 13       | Bearing Bracket      | P77177              |
| 2        | Body Gasket          | P05800              |
| 14       | Front Bearing        | P77087              |
| 15       | Front Bearing Gasket | P80816              |
| 27       | Impeller Key         | P04940              |
|          | Impeller Gasket      | P57000              |
| 9        | Impeller Nut         | P44200 <sup>1</sup> |
| 12       | Oil Well Cover       | P81239              |
| 19       | Oil Wick Set         | 118395              |
| 11       | Seal Kit*            | 118681              |
| 21       | Shaft & Sleeve       | 189035              |

- Factory recommended spare part.

\*For Built-To-Order pumps, see the seal selection chart on page 36.

\*\*115V only. For 230V motor, use 111033.

\*\*\*115V only. For 230V motor, use 111041.

+Cast iron type. For stamped steel, use 189110.

▼ Includes flange gaskets.

▲ Pumps are furnished with sleeve bearing motors. Ball bearing motors are available as replacement only and are completely interchangeable.

<sup>1</sup>On IB pumps, P04650 lockwasher and P04670 nut may be used.

**NOTE:** Refer to page 3 for exploded view of typical circulator.

# PARTS FOR OBSOLETE CIRCULATORS

## MANUFACTURED BETWEEN JANUARY, 1951 & AUGUST, 1976

| ITEM NO. | DESCRIPTION                        | JAN. 1951 - AUG. 1976, 1M-HT |          |          |          | JAN. 1951 - AUG. 1975, 1M-HR |           |           |
|----------|------------------------------------|------------------------------|----------|----------|----------|------------------------------|-----------|-----------|
|          |                                    | 1"                           | 1-1/4"   | 1-1/2"   | 2"       | 1" HV                        | 1-1/4" HV | 1-1/2" HV |
| 1        | Body (Cast Iron or Brass)          | All bodies are obsolete.     |          |          |          |                              |           |           |
|          | Body Capscrew (4 required)         | P03470                       | P03470   | P03470   | P03470   | P03470                       | P03470    | P03470    |
| 4        | Bearing Assemblies:                |                              |          |          |          |                              |           |           |
| 4        | For CI Models w/ Steel Impeller    | 189162                       | 189162   | 189162   | 189163   | 189163                       | 189163    | 189163    |
| 4        | For CI Models w/ Brass Impeller    | 189162                       | 189162   | 189162   | 189163   | 189163                       | 189163    | 189163    |
| 4        | For All Bronze Models              | N/A                          | N/A      | 189163   | 189163   | 189163                       | 189163    | 189163    |
| 8        | Impeller (Steel)                   | 118665                       | 118666   | 118666   | 118668   | 118668                       | 118668    | 118668    |
| 8        | Impeller (Brass)                   | 118434                       | 118435*  | 118435*  | 118436   | 118436                       | 118436    | 118436    |
| 5        | Coupler Assembly                   | 118705+                      | 118705+  | 118705+  | 118705+  | 118705+                      | 118705+   | 118705+   |
|          | Flange (Steel)                     | N/A                          | P03250   | P03410   | F14200   | P00802                       | P03300    | P03410    |
|          | Flange (Brass)                     | P00804                       | P06660   | P06690   | F54200   | P00804                       | P06660    | P06690    |
|          | Flange Gasket Set                  | 118351                       | 118368   | 118373   | 118065   | 118373                       | 118373    | 118373    |
|          | Fastener Package w/ Flange Gaskets | P64230                       | P64910   | P64930   | F91600   | P64930                       | P64930    | P64930    |
| 6        | Power Pack                         | 111031**                     | 111031** | 111031** | 111031** | 111031**                     | 111031**  | 111031**  |
| 22       | Ring Motor Mount Set               | 118223                       | 118223   | 118223   | 118223   | 118223                       | 118223    | 118223    |

+Cast iron type. For stamped steel, use 189110.

\*Used with iron body pump only. Use 118436 impeller with brass body pumps.

\*\*115V only. For 230V, use 111033.

N/A - Not Available.

## BEARING ASSEMBLIES

| ITEM NO. | DESCRIPTION          | 189162 <sup>1</sup> | 189163 <sup>2</sup> |
|----------|----------------------|---------------------|---------------------|
| 13       | Bearing Bracket      | P77106              | P77106              |
| 2        | Body Gasket          | P04890              | P04890              |
| 14       | Front Bearing        | P77308              | P77309              |
| 15       | Front Bearing Gasket | P80816              | P80816              |
| 27       | Impeller Key         | P04940              | P04940              |
|          | Impeller Gasket      | P57000              | P57000              |
| 9        | Impeller Nut         | P44200▲             | P44200              |
| 12       | Oil Well Cover       | P81239              | P81239              |
| 19       | Oil Wick Set         | 118395              | 118395              |
| 11       | Seal Kit▼            | 118681              | 118681              |
| 21       | Shaft & Sleeve       | 189035              | 189035              |

- Factory recommended spare part.

<sup>1</sup> Use the same replacement parts for obsolete bearing assemblies 189100 and 189104.

<sup>2</sup> Replaces obsolete bearing assemblies 189101, 189102 & 189103.

▲On IB pumps, P04650 lockwasher and P04670 nut may be used.

▼For Built-To-Order pumps see the seal selection chart on page 35.

**NOTE:** Refer to page 3 for exploded view of typical circulator.

# PARTS FOR OBSOLETE CIRCULATORS

| MANUFACTURED BETWEEN : |                                    | FEB - SEPT 1976<br>BT-JT |              | APR - SEPT<br>1976<br>DT-JT | SEPT - DEC 1976<br>JT-MT |              | OCT 1975 -<br>APR 1976<br>KR-DT |
|------------------------|------------------------------------|--------------------------|--------------|-----------------------------|--------------------------|--------------|---------------------------------|
|                        |                                    | 1-1/2"                   |              |                             | HV                       |              |                                 |
| ITEM NO.               | DESCRIPTION                        | IB<br>102033             | BI<br>102034 | AB<br>102036                | IB<br>102308             | BI<br>102309 | AB<br>102311                    |
| 1                      | Body (Cast Iron or Brass)          | All bodies are obsolete. |              |                             |                          |              |                                 |
|                        | Body Capscrew (4 required)         | P03470                   | P03470       | P03470                      | P03470                   | P03470       | P03470                          |
| 4                      | Bearing Assembly                   | 189165                   | 189165       | N/A                         | N/A                      | N/A          | N/A                             |
| 8                      | Impeller                           | 118666                   | 118435       | 118436                      | 118668                   | 118436       | 118436                          |
| 5                      | Coupler Assembly                   | 118705+                  | 118705+      | 118705+                     | 118705+                  | 118705+      | 118705+                         |
|                        | Flange (1")                        | -                        | -            | -                           | P00802                   | P00802       | P00804                          |
|                        | Flange (1¼")                       | -                        | -            | -                           | P03300                   | P03300       | P06660                          |
|                        | Flange (1½")                       | P03410                   | P03410       | P06690                      | P03410                   | P03410       | P06690                          |
|                        | Flange Gasket Set                  | 118373                   | 118373       | 118373                      | 118373                   | 118373       | 118373                          |
|                        | Fastener Package w/ Flange Gaskets | P64940                   | P64940       | P64930                      | P64940                   | P64940       | P64930                          |
| 6                      | Power Pack                         | 111061                   | 111061       | 111061                      | 111061                   | 111061       | 111061                          |
| 22                     | Ring Motor Mount Set               | 118223                   | 118223       | 118223                      | 118223                   | 118223       | 118223                          |
| 5 & 22                 | Coupler & Ring Mount Set           | 118706                   | 118706       | 118706                      | 118706                   | 118706       | 118706                          |

+Cast iron type. For stamped steel, use 189110.

N/A - Not Available.

## BEARING ASSEMBLIES

| ITEM NO. | DESCRIPTION          | 189165 | HVIB (a) | HVBI (b) | 1-1/2" AB & HVAB (c) |
|----------|----------------------|--------|----------|----------|----------------------|
| 13       | Bearing Bracket      | P77139 | P77139   | P77139   | P77139               |
| 2        | Body Gasket          | P04890 | P04890   | P04890   | P04890               |
| 14       | Front Bearing        | P77308 | P77309   | P77309   | P77309               |
| 15       | Front Bearing Gasket | P80816 | P80816   | P80816   | P80816               |
| 27       | Impeller Key         | P04940 | P04940   | P04940   | P04940               |
|          | Impeller Gasket      | P57000 | NONE     | NONE     | P57000               |
| 9        | Impeller Nut         | P44200 | J91702   | J91702   | P44200               |
| 12       | Oil Well Cover       | P81239 | P81239   | P81239   | P81239               |
| 19       | Oil Wick Set         | 118395 | 118395   | 118395   | 118395               |
| 11       | Seal Kit*            | 118681 | 118681   | 118681   | 118681               |
| 21       | Shaft & Sleeve       | 189035 | 189035   | 189035   | 189035               |

- Factory recommended spare part.

(a) Replacement parts for obsolete bearing assembly 189121.

(b) Replacement parts for obsolete bearing assembly 189129.

(c) Replacement parts for obsolete bearing assembly 189131.

\*For Built-To-Order pumps, see the seal selection chart on page 35.

**NOTE:** Refer to page 3 for exploded view of typical circulator.

## PARTS FOR SERIES PD

| ITEM NO. | DESCRIPTION                        | PD-35    | PD-37    | PD-39† | Manufactured Prior to B40 Date Code (3 PH) E40 Date Code (1 PH) |        | Manufactured Date Code B40 & After (3 PH) Code E40 & After (1 PH) |        |
|----------|------------------------------------|----------|----------|--------|---|--------|---|--------|
|          |                                    |          |          |        | PD-38   | PD-40  | PD-38   | PD-40  |
| 1        | Body (Cast Iron)                   | 118449   | 118449   | P08460 | P08460  | P08460 | P08460  | P08460 |
| 1        | Body (Bronze)                      | P09290   | P09290   | P08440 | P08440  | P08440 | P08440  | P08440 |
| 7        | Body Capscrew (8 Required)         | P10620   | P10620   | P40020 | P40020  | P40020 | P40020  | P40020 |
| 4        | Bearing Assembly:                  |          |          |        |   |        |   |        |
|          | For Cast Iron Models               | 186863   | 186863   | 185260 | 185260  | 185260 | 185333  | 185333 |
|          | For Bronze Models                  | 186863   | 186863   | 185262 | 185262  | 185262 | 185334  | 185334 |
| 8        | Impeller (Steel)                   | 118630   | 118629   | 118452 | P08709  | 118452 | P08709  | 118452 |
| 8        | Impeller (Brass)                   | 118627   | 118626   | 118453 | P08690  | 118453 | P08690  | 118453 |
|          | Fastener Package w/ Flange Gaskets | P65130*  | P65130*  | P09540 | P09540  | P09540 | P09540  | P09540 |
|          | Flange Gasket Set                  | 118129   | 118129   | 118129 | 118129  | 118129 | 118129  | 118129 |
|          | Flange (Steel)                     | F74000   | F74000   | A24600 | A24600  | A24600 | A24600  | A24600 |
|          | Flange (Brass)                     | F74800   | F74800   | A40000 | A40000  | A40000 | A40000  | A40000 |
| 6        | Power Pack (1 Phase)               | 111044   | 111047   | N/A    | N/A   | N/A    | 169232  | 169236 |
| 6        | Power Pack ((3 Phase)              | 111046   | 111049   | N/A    | N/A   | N/A    | 169233  | 169237 |
|          | Ring Motor Mount Set               | 118228   | 118228   | 118848 | 118848  | NONE   | 118848  | NONE   |
|          | Coupler & Ring Mount Set           | 118474** | 118474** | NONE   | NONE  | NONE   | NONE  | NONE   |

\*Does not include flange gaskets.

\*\*Set includes 118473 coupler & 118228 motor mounts

†For replacement parts purposes only. The PD-39 pump is no longer available.

N/A - No longer available. See note below.

**NOTE: Sleeve bearing (oil lubricated) power packs and maintenance-free ball bearing power packs are interchangeable.** Refer to the Power Pack Cross Reference chart on page 30.

### SLEEVE BEARING ASSEMBLIES

| ITEM NO. | DESCRIPTION                    | IB, AB<br>186863 | AI<br>186865 | IB<br>185260        | AI<br>185261        | AB<br>185262        |
|----------|--------------------------------|------------------|--------------|---------------------|---------------------|---------------------|
| 13       | Bearing Bracket                | P77179           | P77179       | P57282              | P57282              | P57282              |
| 17       | Coverplate                     | NONE             | NONE         | P57246              | P57246              | P57248              |
| 2        | Body Gasket                    | P57410           | P57410       | P57700              | P57700              | P57700              |
|          | Coupler Key                    | NONE             | NONE         | H32400              | H32400              | H32400              |
|          | Impeller Key                   | P04940           | P04940       | P49358              | P49358              | P49358              |
| 3        | Impeller Washer                | P57000▲          | P04650       | P11150              | P11150              | P11220              |
| 9        | Impeller Nut                   | P44200▲          | P04670       | P45910              | P45910              | P08480              |
| 12       | Oil Well Cover                 | P81239           | P81239       | P57302              | P57302              | P57302              |
| 18       | Oil Well Gasket                | NONE             | NONE         | P57300              | P57300              | P57300              |
| 19       | Oil Wick Set                   | 118395           | 118395       | P04883<br>(2 Req'd) | P04883<br>(2 Req'd) | P04883<br>(2 Req'd) |
| 20       | Oil Wick Retainer (2 Required) | NONE             | NONE         | P12422              | P12422              | P12422              |
| 14       | Front Bearing                  | P77216           | P77215       | 185241              | 185241              | 185241              |
| 16       | Rear Bearing                   | NONE             | NONE         | 185240              | 185240              | 185240              |
| 15       | Front Bearing Gasket           | P80816           | P80816       | NONE                | NONE                | NONE                |
| 11       | Seal Kit▼                      | 118681           | 186681       | 186499              | 186433              | 186499              |
| 21       | Shaft & Sleeve                 | 189035           | P81960       | 118469              | P08725              | 118469              |

- Factory recommended spare part.

▲ On IB pumps, P04650 lockwasher and P04670 nut may be used.

**NOTE: Sleeve bearing assemblies (oil lubricated) and XL-11™ bearing assemblies (maintenance-free) are interchangeable.** See Bearing Assembly Cross Reference chart on page 31.

### COUPLER SELECTION TABLE

| PUMP SHAFT SIZE | PUMP SERIES                          | HP            | FRAME SIZE | MOTOR SHAFT SIZE | COUPLER NO. |
|-----------------|--------------------------------------|---------------|------------|------------------|-------------|
| 1/2"            | PD-35 & PD-37                        | 1/2 & 3/4     | B&G        | 1/2"             | 118473      |
| 1/2"            | PD-37<br>w/ Maint Free Motor         | 3/4           | B&G        | 1/2"             | 185329      |
| 1/2"            | PD-35 & PD-37                        | 1/2 & 3/4     | 56-57-65   | 5/8"             | 118709      |
| 1/2"            | PD-35 & PD-37                        | 1/2 & 3/4     | 66-75      | 3/4"             | 118708      |
| 5/8"            | PD-38 & PD-39                        | 1             | 56         | 5/8"             | 186004      |
| 5/8"            | PD-38 & PD-39<br>w/ Maint Free Motor | 1             | B&G        | 1/2"             | 185330      |
| 5/8"            | PD-40                                | 1 & 1-<br>1/2 | 56-145TZ   | 5/8"             | 186003      |

▼ For Built-to-Order pumps, see the seal selection chart on page 36.

Note: Refer to pages 4 and 7 for exploded views of pump and bearing assembly.

# How to Select Parts for Maintenance Free Series 60, Pages 17-23

The pump nameplate identifies the pump by model number, pump construction and impeller diameter as shown below.

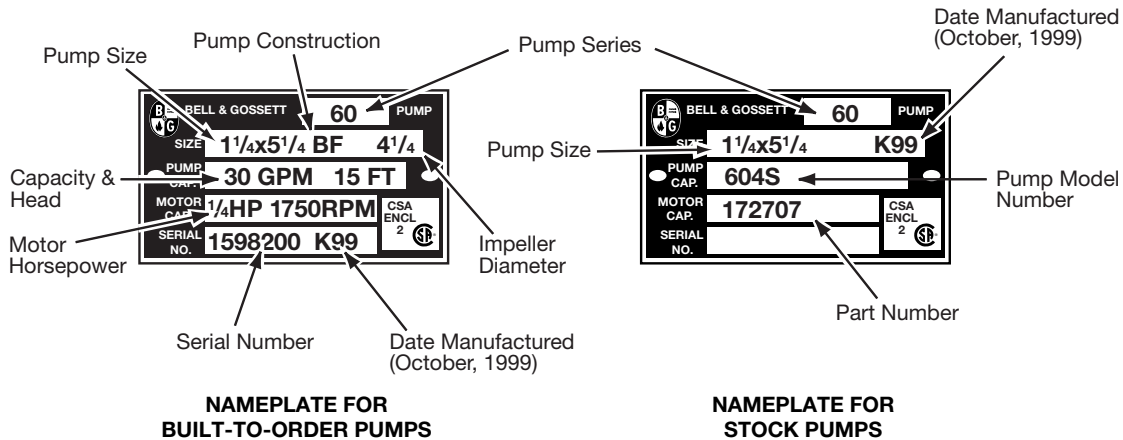

The BTO nameplate above identifies the pump as a Series 60, size 1 1/4x5 1/4 in bronze fitted (BF) construction. The impeller diameter is 4 1/4" and is capable of pumping 30 GPM at 15 FT. The motor horsepower is 1/4, the RPM is 1750. The serial number specifically identifies the unit for future reference. **DO NOT REMOVE THE NAMEPLATE.** It is important when ordering replacement parts to furnish complete nameplate data.

Following the procedure below will result in proper parts selection.

1. Determine from the nameplate the model number, pump construction and impeller diameter.
2. Refer to the index for the page number of the parts breakdown for the specific model pump.
3. Find the proper column in the parts breakdown for the pump construction involved.
4. Select part numbers using the numbered drawings on page 4 for identification.



# PARTS FOR MAINTENANCE FREE SERIES 60 STANDARD SIZE DESIGNATIONS

| PUMP SIZE     | EQUIVALENT SIZE | HP  | (6) MOTOR              |                        | (5)     | (4)                 | (8)                               |          |
|---------------|-----------------|-----|------------------------|------------------------|---------|---------------------|-----------------------------------|----------|
|               |                 |     | 1 PHASE<br>115/208-230 | 3 PHASE<br>208-230/460 | COUPLER | BEARING<br>ASSEMBLY | IMPELLER<br>DIAMETER              | IMPELLER |
| 601S & 601T   | 1x1x5¼          | 1/4 | 169224                 | 169225                 | 118473  | 185332              | 4 <sup>3</sup> / <sub>8</sub> "   | P82878   |
| B601S & B601T | 1x1x5¼          | 1/4 | 169224                 | 169225                 | 118473  | 185332              | 4 <sup>3</sup> / <sub>8</sub> "   | P82878   |
| 602S & 602T   | 1x1x5¼          | 1/3 | 169226                 | 169227                 | 118473  | 185332              | 4 <sup>27</sup> / <sub>32</sub> " | P82877   |
| B602S & B602T | 1x1x5¼          | 1/3 | 169226                 | 169227                 | 118473  | 185332              | 4 <sup>27</sup> / <sub>32</sub> " | P82877   |
| 603S & 603T   | 1x1x5¼          | 1/2 | 169228                 | 169229                 | 118473  | 185332              | 5¼"                               | P58541   |
| B603S & B603T | 1x1x5¼          | 1/2 | 169228                 | 169229                 | 118473  | 185332              | 5¼"                               | P58541   |
| 604S & 604T   | 1¼x1¼x5¼        | 1/4 | 169224                 | 169225                 | 118473  | 185332              | 4 <sup>3</sup> / <sub>8</sub> "   | P82878   |
| B604S & B604T | 1¼x1¼x5¼        | 1/4 | 169224                 | 169225                 | 118473  | 185332              | 4 <sup>3</sup> / <sub>8</sub> "   | P82878   |
| 605S & 605T   | 1¼x1¼x5¼        | 1/3 | 169226                 | 169227                 | 118473  | 185332              | 4 <sup>27</sup> / <sub>32</sub> " | P82877   |
| B605S & B605T | 1¼x1¼x5¼        | 1/3 | 169226                 | 169227                 | 118473  | 185332              | 4 <sup>27</sup> / <sub>32</sub> " | P82877   |
| 606S & 606T   | 1¼x1¼x5¼        | 1/2 | 169228                 | 169229                 | 118473  | 185332              | 5¼"                               | P58541   |
| B606S & B606T | 1¼x1¼x5¼        | 1/2 | 169228                 | 169229                 | 118473  | 185332              | 5¼"                               | P58541   |
| 607S & 607T   | 1½x1½x5¼        | 1/3 | 169226                 | 169227                 | 118473  | 185332              | 4 <sup>3</sup> / <sub>8</sub> "   | P82881   |
| B607S & B607T | 1½x1½x5¼        | 1/3 | 169226                 | 169227                 | 118473  | 185332              | 4 <sup>3</sup> / <sub>8</sub> "   | P82881   |
| 608S & 608T   | 1½x1½x5¼        | 1/2 | 169228                 | 169229                 | 118473  | 185332              | 4 <sup>15</sup> / <sub>16</sub> " | P82880   |
| B608S & B608T | 1½x1½x5¼        | 1/2 | 169228                 | 169229                 | 118473  | 185332              | 4 <sup>15</sup> / <sub>16</sub> " | P82880   |
| 609S & 609T   | 1½x1½x5¼        | 3/4 | 169230                 | 169231                 | 185329  | 185332              | 5¼"                               | P58538   |
| B609S & B609T | 1½x1½x5¼        | 3/4 | 169230                 | 169231                 | 185329  | 185332              | 5¼"                               | P58538   |
| 610S & 610T   | 2x2x5¼          | 1/2 | 169228                 | 169229                 | 118473  | 185332              | 4 <sup>1</sup> / <sub>8</sub> "   | P82883   |
| B610S & B610T | 2x2x5¼          | 1/2 | 169228                 | 169229                 | 118473  | 185332              | 4 <sup>1</sup> / <sub>8</sub> "   | P82883   |
| 611S & 611T   | 2x2x5¼          | 3/4 | 169230                 | 169231                 | 185329  | 185332              | 4 <sup>3</sup> / <sub>4</sub> "   | P82882   |
| B611S & B611T | 2x2x5¼          | 3/4 | 169230                 | 169231                 | 185329  | 185332              | 4 <sup>3</sup> / <sub>4</sub> "   | P82882   |
| 612S & 612T   | 2x2x5¼          | 1   | 169232                 | 169233                 | 185329  | 185332              | 5¼"                               | P58536   |
| B612S & B612T | 2x2x5¼          | 1   | 169232                 | 169233                 | 185329  | 185332              | 5¼"                               | P58536   |
| 613S & 613T   | 1½x1½x6¼        | 3/4 | 169230                 | 169231                 | 185329  | 185332*             | 5 <sup>3</sup> / <sub>4</sub> "   | P82884   |
| 614S & 614T   | 1½x1½x6¼        | 1   | 169232                 | 169233                 | 185329  | 185332*             | 6¼"                               | P58564   |
| B614S & B614T | 1½x1½x6¼        | 1   | 169232                 | 169233                 | 185329  | 185332*             | 6¼"                               | P58564   |
| 615S & 615T   | 2x2x6¼          | 3/4 | 169230                 | 169231                 | 185329  | 185332*             | 5 <sup>5</sup> / <sub>8</sub> "   | P82885   |
| B615S & B615T | 2x2x6¼          | 3/4 | 169230                 | 169231                 | 185329  | 185332*             | 5 <sup>5</sup> / <sub>8</sub> "   | P82885   |
| 616S & 616T   | 2x2x6¼          | 1   | 169232                 | 169233                 | 185329  | 185332*             | 6 <sup>7</sup> / <sub>32</sub> "  | P58562   |
| 617S & 617T   | 1½x1½x7         | 1½  | 169236                 | 169237                 | 186003  | 185333              | 6½"                               | P57460   |
| 618T          | 1½x1½x7         | 2   | NONE                   | 169238                 | 186003  | 185333              | 7"                                | P57440   |
| 619T          | 2x2x7           | 2   | NONE                   | 169238                 | 186003  | 185333              | 6½"                               | P82137   |
| 620T          | 2x2x7           | 3   | NONE                   | 169234                 | 185331  | 185333              | 7"                                | P57580   |
| 621S & 621T   | 1½X1½X6¼        | 1/2 | 169228                 | 169229                 | 118473  | 185332*             | 4 <sup>7</sup> / <sub>8</sub> "   | P58661   |
| B621S & B621T | 1½X1½X6¼        | 1/2 | 169228                 | 169229                 | 118473  | 185332*             | 4 <sup>7</sup> / <sub>8</sub> "   | P58661   |
| 622S & 622T   | 1½X1½X7         | 3/4 | 169230                 | 169231                 | 186410  | 185333              | 5½"                               | P58662   |
| 623S & 623T   | 1½X1½X7         | 1   | 169232                 | 169233                 | 185330  | 185333              | 6"                                | P58663   |
| 624S & 624T   | 2x2x7           | 1   | 169232                 | 169233                 | 185330  | 185333              | 5 <sup>11</sup> / <sub>16</sub> " | P58664   |
| 625S & 625T   | 2x2x7           | 1½  | 169236                 | 169237                 | 186003  | 185333              | 6 <sup>1</sup> / <sub>8</sub> "   | P58665   |
| 626S & 626T   | 3x3x5¼          | 3/4 | 169230                 | 169231                 | 185329  | 185332              | 4 <sup>3</sup> / <sub>8</sub> "   | P83023   |
| B626S & B626T | 3x3x5¼          | 3/4 | 169230                 | 169231                 | 185329  | 185332              | 4 <sup>3</sup> / <sub>8</sub> "   | P83023   |
| 627S & 627T   | 3x3x5¼          | 1½  | 169236                 | 169237                 | P75421  | 185332              | 5¼"                               | P58536   |
| B627S & B627T | 3x3x5¼          | 1½  | 169236                 | 169237                 | P75421  | 185332              | 5¼"                               | P58536   |

\*Adapter ring gasket P58542 must also be ordered when bearing assembly is replaced on all 6¼" pumps.

— Factory recommended spare parts.

Note: Refer to page 4 for exploded view of pump.

# PARTS FOR MAINTENANCE FREE SERIES 60

## 1x1x5¼

| ITEM NO. | DESCRIPTION                        | BRONZE FITTED | ALL BRONZE |
|----------|------------------------------------|---------------|------------|
| 1        | Volute                             | 186386        | 186931     |
| 10       | Volute Drain Plug (5 Req'd)        | P39020        | P39470     |
| 7        | Volute Capscrew (8 Req'd)          | P10620        | P10620     |
| 2        | Volute Gasket                      | P57410        | P57410     |
| 8        | Impeller (State Diameter)          | P58541        | P58541     |
|          | Impeller Key                       | P04940        | P04940     |
| 9        | Impeller Nut                       | P44200        | P44200     |
| 3        | Impeller Washer                    | P04660        | P04660     |
|          | Flange (2 Req'd)                   | P01510        | P00836     |
|          | Fastener Package w/ Flange Gaskets | P64910        | P64910     |
|          | Flange Gasket Set                  | 118368        | 118368     |

## 1¼x1¼x5¼

| ITEM NO. | DESCRIPTION                        | BRONZE FITTED | ALL BRONZE |
|----------|------------------------------------|---------------|------------|
| 1        | Volute                             | 186386        | 186931     |
| 10       | Volute Drain Plug (5 Req'd)        | P39020        | P39470     |
| 7        | Volute Capscrew (8 Req'd)          | P10620        | P10620     |
| 2        | Volute Gasket                      | P57410        | P57410     |
| 8        | Impeller (State Diameter)          | P58541        | P58541     |
|          | Impeller Key                       | P04940        | P04940     |
| 9        | Impeller Nut                       | P44200        | P44200     |
| 3        | Impeller Washer                    | P04660        | P04660     |
|          | Flange (2 Req'd)                   | P03250        | P00837     |
|          | Fastener Package w/ Flange Gaskets | P64910        | P64910     |
|          | Flange Gasket Set                  | 118368        | 118368     |

## XL-11™ BEARING ASSEMBLIES (FOR BF OR AB PUMPS)

| ITEM NO. | DESCRIPTION                             | MODELS WITH COPPER SHAFT SLEEVE     |                                  |                                    | MODELS WITH STAINLESS STEEL SHAFT SLEEVE |                                  |                                    |
|----------|---|-------------------------------------|----------------------------------|------------------------------------|--|----------------------------------|------------------------------------|
|          |   | 185332                              | 185355                           | 185356                             | 185357                                   | 185358                           | 185359                             |
| 4        | Bearing Assy. – Includes the Following: |                                     |                                  |                                    |  |                                  |                                    |
| 11       | Seal Kit No.<br><i>Seal Type</i>        | 118681<br><i>Buna-N<sup>1</sup></i> | 185230<br><i>EPT<sup>2</sup></i> | 186875<br><i>Viton<sup>3</sup></i> | 118681<br><i>Buna-N<sup>1</sup></i>      | 185230<br><i>EPT<sup>2</sup></i> | 186875<br><i>Viton<sup>3</sup></i> |
|          | XL-11™ Small Bearing Frame Repair Kit*  | 185335                              | 185335                           | 185335                             | 185336                                   | 185336                           | 185336                             |
| 2        | Volute Gasket                           | P57410                              | P57410                           | P57410                             | P57410                                   | P57410                           | P57410                             |

<sup>1</sup>Buna/Carbon/Ceramic    <sup>2</sup>EPT/Carbon/Tungsten Carbide    <sup>3</sup>Viton/Carbon/Ceramic

\*Includes pre-assembled faceplate, nose cone, shaft and bearings. Wave spring and volute gasket are also supplied.

## ITEM NO. 5 COUPLERS

*See chart on page 23*

## ITEM NO. 6 POWER PACKS

| HP  | 1 PHASE<br>115/208-230 | 3 PHASE<br>208-230/460 | RING<br>MOUNTS |
|-----|------------------------|------------------------|----------------|
| 1/4 | 169224                 | 169225                 | 118228         |
| 1/3 | 169226                 | 169227                 | 118228         |
| 1/2 | 169228                 | 169229                 | 118228         |
| 3/4 | 169230                 | 169231                 | 118228         |

— Factory recommended spare parts.

Note: Refer to page 4 for exploded view of pump.

# PARTS FOR MAINTENANCE FREE SERIES 60

## 1½x1½x5¼

| ITEM NO. | DESCRIPTION                        | BRONZE FITTED | ALL BRONZE |
|----------|------------------------------------|---------------|------------|
| 1        | Volute                             | 186389        | 186932     |
| 10       | Volute Drain Plug (5 Req'd)        | P39020        | P39470     |
| 7        | Volute Capscrew (8 Req'd)          | P10620        | P10620     |
| 2        | Volute Gasket                      | P57410        | P57410     |
| 8        | Impeller (State Diameter)          | P58538        | P58538     |
|          | Impeller Key                       | P04940        | P04940     |
| 9        | Impeller Nut                       | P44200        | P44200     |
| 3        | Impeller Washer                    | P04660        | P04660     |
|          | Flange (2 Req'd)                   | P03410        | P06690     |
|          | Fastener Package w/ Flange Gaskets | P64940        | P64930     |
|          | Flange Gasket Set                  | 118373        | 118373     |

## 2x2x5¼

| ITEM NO. | DESCRIPTION                                 | BRONZE FITTED | ALL BRONZE |
|----------|---|---------------|------------|
| 1        | Volute                                      | 186392        | 186933     |
| 10       | Volute Drain Plug (5 Req'd)                 | P39020        | P39470     |
| 7        | Volute Capscrew (8 Req'd)                   | P10620        | P10620     |
| 2        | Volute Gasket                               | P57410        | P57410     |
| 8        | Impeller (State Diameter)                   | P58536        | P58536     |
|          | Impeller Key                                | P04940        | P04940     |
| 9        | Impeller Nut                                | P44200        | P44200     |
| 3        | Impeller Washer                             | P04660        | P04660     |
|          | Flange (2 Req'd)                            | F14200        | F54200     |
|          | Fastener Package w/ Flange Gasket (2 Req'd) | P65031        | P65030     |
|          | Flange Gasket Set                           | 118378        | 118378     |
|          | Motor Ring Adapter                          | P76944        | P76944     |

## XL-11™ BEARING ASSEMBLIES (FOR BF OR AB PUMPS)

| ITEM NO. | DESCRIPTION                             | MODELS WITH COPPER SHAFT SLEEVE     |                                  |                                    | MODELS WITH STAINLESS STEEL SHAFT SLEEVE |                                  |                                    |
|----------|---|-------------------------------------|----------------------------------|------------------------------------|--|----------------------------------|------------------------------------|
|          |   |                                     |                                  |                                    |  |                                  |                                    |
| 4        | Bearing Assy. – Includes the Following: | 185332                              | 185355                           | 185356                             | 185357                                   | 185358                           | 185359                             |
| 11       | Seal Kit No.<br>Seal Type               | 118681<br><i>Buna-N<sup>1</sup></i> | 185230<br><i>EPT<sup>2</sup></i> | 186875<br><i>Viton<sup>3</sup></i> | 118681<br><i>Buna-N<sup>1</sup></i>      | 185230<br><i>EPT<sup>2</sup></i> | 186875<br><i>Viton<sup>3</sup></i> |
|          | XL-11™ Small Bearing Frame Repair Kit*  | 185335                              | 185335                           | 185335                             | 185336                                   | 185336                           | 185336                             |
| 2        | Volute Gasket                           | P57410                              | P57410                           | P57410                             | P57410                                   | P57410                           | P57410                             |

<sup>1</sup>Buna/Carbon/Ceramic    <sup>2</sup>EPT/Carbon/Tungsten Carbide    <sup>3</sup>Viton/Carbon/Ceramic

\*Includes pre-assembled faceplate, nose cone, shaft and bearings. Wave spring and volute gasket are also supplied.

## ITEM NO. 5 COUPLERS

See chart on page 23

## ITEM NO. 6 POWER PACKS

| HP  | 1 PHASE<br>115/208-230 | 3 PHASE<br>208-230/460 | RING<br>MOUNTS |
|-----|------------------------|------------------------|----------------|
| 1/4 | 169224                 | 169225                 | 118228         |
| 1/3 | 169226                 | 169227                 | 118228         |
| 1/2 | 169228                 | 169229                 | 118228         |
| 3/4 | 169230                 | 169231                 | 118228         |
| 1   | 169232                 | 169233                 | 118848         |
| 1½  | 169236                 | 169237                 | NONE           |

— Factory recommended spare parts.

Note: Refer to page 4 for exploded view of pump.

# PARTS FOR MAINTENANCE FREE SERIES 60

3x3x5¼

| ITEM NO. | DESCRIPTION                 | BRONZE FITTED | ALL BRONZE |
|----------|-----------------------------|---------------|------------|
| 1        | Volute                      | 118449        | P09290     |
| 10       | Volute Drain Plug (5 Req'd) | P39020        | P39470     |
| 7        | Volute Capscrew (8 Req'd)   | P10620        | P01850     |
| 2        | Volute Gasket               | P57410        | P57410     |
| 8        | Impeller (State Diameter)   | P58536        | P58536     |
|          | Impeller Key                | P04940        | P04940     |
| 9        | Impeller Nut                | P44200        | P44200     |
| 3        | Impeller Washer             | P04660        | P04660     |
|          | Flange (2 Req'd)            | F74000        | F74800     |
|          | Fastener Package**          | P65130        | P65130     |
|          | Flange Gasket Set           | 118129        | 118129     |
|          | Motor Ring Adapter          | P76944        | P76944     |

\*\*Does not include flange gaskets.

## XL-11™ BEARING ASSEMBLIES (FOR BF OR AB PUMPS)

| ITEM NO. | DESCRIPTION                             | MODELS WITH COPPER SHAFT SLEEVE     |                                  |                                    | MODELS WITH STAINLESS STEEL SHAFT SLEEVE |                                  |                                    |
|----------|---|-------------------------------------|----------------------------------|------------------------------------|--|----------------------------------|------------------------------------|
|          |   | 185332                              | 185355                           | 185356                             | 185357                                   | 185358                           | 185359                             |
| 4        | Bearing Assy. – Includes the Following: | 185332                              | 185355                           | 185356                             | 185357                                   | 185358                           | 185359                             |
| 11       | Seal Kit No.<br>Seal Type               | 118681<br><i>Buna-N<sup>1</sup></i> | 185230<br><i>EPT<sup>2</sup></i> | 186875<br><i>Viton<sup>3</sup></i> | 118681<br><i>Buna-N<sup>1</sup></i>      | 185230<br><i>EPT<sup>2</sup></i> | 186875<br><i>Viton<sup>3</sup></i> |
|          | XL-11™ Small Bearing Frame Repair Kit*  | 185335                              | 185335                           | 185335                             | 185336                                   | 185336                           | 185336                             |
| 2        | Volute Gasket                           | P57410                              | P57410                           | P57410                             | P57410                                   | P57410                           | P57410                             |

<sup>1</sup>Buna/Carbon/Ceramic    <sup>2</sup>EPT/Carbon/Tungsten Carbide    <sup>3</sup>Viton/Carbon/Ceramic

\*Includes pre-assembled faceplate, nose cone, shaft and bearings. Wave spring and volute gasket are also supplied.

## ITEM NO. 5 COUPLERS

See chart on page 23

## ITEM NO. 6 POWER PACKS

| HP  | 1 PHASE<br>115/208-230 | 3 PHASE<br>208-230/460 | RING<br>MOUNTS |
|-----|------------------------|------------------------|----------------|
| 1/3 | 169226                 | 169227                 | 118228         |
| 1/2 | 169228                 | 169229                 | 118228         |
| 3/4 | 169230                 | 169231                 | 118228         |
| 1   | 169232                 | 169233                 | 118848         |
| 1½  | 169236                 | 169237                 | NONE           |

— Factory recommended spare parts.  
Note: Refer to page 4 for exploded view of pump.

# PARTS FOR MAINTENANCE FREE SERIES 60

## 1½x1½x6¼

| ITEM NO. | DESCRIPTION                        | BRONZE FITTED | ALL BRONZE |
|----------|------------------------------------|---------------|------------|
| 1        | Volute                             | 186935        | 186671     |
| 10       | Volute Drain Plug (5 Req'd)        | P39020        | P39470     |
| 7        | Volute Capscrew (8 Req'd)          | P10620        | P10620     |
| 2        | Volute Gasket                      | P57410        | P57410     |
| 23       | Adapter Ring                       | P58576        | P58578     |
| 24       | Adapter Ring Capscrew (8 Req'd)    | DJ0034        | P10620     |
| 25       | Adapter Ring Gasket                | P58542        | P58542     |
| 8        | Impeller (State Diameter)          | P58564        | P58564     |
|          | Impeller Key                       | P04940        | P04940     |
| 9        | Impeller Nut                       | P44200        | P44200     |
| 3        | Impeller Washer                    | P04660        | P04660     |
|          | Flange (2 Req'd)                   | P03410        | P06690     |
|          | Fastener Package w/ Flange Gaskets | P64940        | P64930     |
|          | Flange Gasket Set                  | 118373        | 118373     |
|          | Motor Ring Adapter                 | P76944        | P76944     |

## 2x2x6¼

| ITEM NO. | DESCRIPTION                                 | BRONZE FITTED | ALL BRONZE |
|----------|---|---------------|------------|
| 1        | Volute                                      | 186936        | 186672     |
| 10       | Volute Drain Plug (5 Req'd)                 | P39020        | P39470     |
| 7        | Volute Capscrew (8 Req'd)                   | P10620        | P10620     |
| 2        | Volute Gasket                               | P57410        | P57410     |
| 23       | Adapter Ring                                | P58576        | P58578     |
| 24       | Adapter Ring Capscrew (8 Req'd)             | DJ0034        | P10620     |
| 25       | Adapter Ring Gasket                         | P58542        | P58542     |
| 8        | Impeller (State Diameter)                   | P58562        | P58562     |
|          | Impeller Key                                | P04940        | P04940     |
| 9        | Impeller Nut                                | P44200        | P44200     |
| 3        | Impeller Washer                             | P04660        | P04660     |
|          | Flange (2 Req'd)                            | F14200        | F54200     |
|          | Fastener Package w/ Flange Gasket (2 Req'd) | P65031        | P65030     |
|          | Flange Gasket Set                           | 118378        | 118378     |
|          | Motor Ring Adapter                          | P76944        | P76944     |

## XL-11™ BEARING ASSEMBLIES (FOR BF OR AB PUMPS)

| ITEM NO. | DESCRIPTION                             | MODELS WITH COPPER SHAFT SLEEVE     |                                  |                                    | MODELS WITH STAINLESS STEEL SHAFT SLEEVE |                                  |                                    |
|----------|---|-------------------------------------|----------------------------------|------------------------------------|--|----------------------------------|------------------------------------|
|          |   | 185332**                            | 185355**                         | 185356**                           | 185357**                                 | 185358**                         | 185359**                           |
| 4        | Bearing Assy. – Includes the Following: |                                     |                                  |                                    |  |                                  |                                    |
| 11       | Seal Kit No.<br><i>Seal Type</i>        | 118681<br><i>Buna-N<sup>1</sup></i> | 185230<br><i>EPT<sup>2</sup></i> | 186875<br><i>Viton<sup>3</sup></i> | 118681<br><i>Buna-N<sup>1</sup></i>      | 185230<br><i>EPT<sup>2</sup></i> | 186875<br><i>Viton<sup>3</sup></i> |
|          | XL-11™ Small Bearing Frame Repair Kit*  | 185335                              | 185335                           | 185335                             | 185336                                   | 185336                           | 185336                             |
| 2        | Volute Gasket                           | P57410                              | P57410                           | P57410                             | P57410                                   | P57410                           | P57410                             |

<sup>1</sup>Buna/Carbon/Ceramic    <sup>2</sup>EPT/Carbon/Tungsten Carbide    <sup>3</sup>Viton/Carbon/Ceramic

\*Includes pre-assembled faceplate, nose cone, shaft and bearings. Wave spring and volute gasket are also supplied.

\*\*Adapter Ring Gasket P58542 must also be ordered when bearing assembly is replaced on all 6-1/4" pumps.

## ITEM NO. 5 COUPLERS

See chart on page 23

## ITEM NO. 6 POWER PACKS

| HP  | 1 PHASE<br>115/208-230 | 3 PHASE<br>208-230/460 | RING<br>MOUNTS |
|-----|------------------------|------------------------|----------------|
| 1/2 | 169228                 | 169229                 | 118228         |
| 3/4 | 169230                 | 169231                 | 118228         |
| 1   | 169232                 | 169233                 | 118848         |
| 1½  | 169236                 | 169237                 | NONE           |

— Factory recommended spare parts.

Note: Refer to page 4 for exploded view of pump.

# PARTS FOR MAINTENANCE FREE SERIES 60

## 1½x1½x7

| ITEM NO. | DESCRIPTION                        | BRONZE FITTED | ALL BRONZE |
|----------|------------------------------------|---------------|------------|
| 1        | Volute                             | 186390        | 186934     |
| 10       | Volute Drain Plug (5 Req'd)        | P39020        | P39470     |
| 7        | Volute Capscrew (8 Req'd)          | P40020        | P52310     |
| 2        | Volute Gasket                      | P57700        | P57700     |
| 8        | Impeller (State Diameter)          | P57440        | P57440     |
|          | Impeller Key                       | P49358        | P49358     |
| 9        | Impeller Nut                       | P08480        | P08480     |
| 3        | Impeller Washer                    | P11220        | P11220     |
|          | Flange (2 Req'd)                   | P03410        | P06690     |
|          | Fastener Package w/ Flange Gaskets | P64940        | P64930     |
|          | Flange Gasket Set                  | 118373        | 118373     |

## 2x2x7

| ITEM NO. | DESCRIPTION                                 | BRONZE FITTED | ALL BRONZE |
|----------|---|---------------|------------|
| 1        | Volute                                      | 186937        | 186938     |
| 10       | Volute Drain Plug (5 Req'd)                 | P39020        | P39470     |
| 7        | Volute Capscrew (8 Req'd)                   | P40020        | P52310     |
| 2        | Volute Gasket                               | P57700        | P57700     |
| 8        | Impeller (State Diameter)                   | P57580        | P57580     |
|          | Impeller Key                                | P49358        | P49358     |
| 9        | Impeller Nut                                | P08480        | P08480     |
| 3        | Impeller Washer                             | P11220        | P11220     |
|          | Flange (2 Req'd)                            | F14200        | F54200     |
|          | Fastener Package w/ Flange Gasket (2 Req'd) | P65031        | P65030     |
|          | Flange Gasket Set                           | 118378        | 118378     |

## XL-11™ BEARING ASSEMBLIES

| ITEM NO. | DESCRIPTION                                | FOR BRONZE FITTED PUMPS         |                            |                          |                               |                            |                          | FOR ALL BRONZE PUMPS            |                            |                          |                               |                            |                          |
|----------|--|---------------------------------|----------------------------|--------------------------|-------------------------------|----------------------------|--------------------------|---------------------------------|----------------------------|--------------------------|-------------------------------|----------------------------|--------------------------|
|          |  | MODELS WITH COPPER SHAFT SLEEVE |                            |                          | MODELS WITH SS SHAFT SLEEVE   |                            |                          | MODELS WITH COPPER SHAFT SLEEVE |                            |                          | MODELS WITH SS SHAFT SLEEVE   |                            |                          |
| 4        | Bearing Assembly - Includes the following: | 185333                          | 185360                     | 185361                   | 185362                        | 185363                     | 185364                   | 185334                          | 185365                     | 185366                   | 185367                        | 185368                     | 185369                   |
| 11       | Seal Kit No.<br>Seal Type                  | 186499<br>Buna-N <sup>1</sup>   | 185223<br>EPT <sup>2</sup> | CF<br>Viton <sup>3</sup> | 186499<br>Buna-N <sup>1</sup> | 185223<br>EPT <sup>2</sup> | CF<br>Viton <sup>3</sup> | 186499<br>Buna-N <sup>1</sup>   | 185223<br>EPT <sup>2</sup> | CF<br>Viton <sup>3</sup> | 186499<br>Buna-N <sup>1</sup> | 185223<br>EPT <sup>2</sup> | CF<br>Viton <sup>3</sup> |
|          | XL-11™ Large Bearing<br>Frame Repair Kit*  | 185337                          | 185337                     | 185337                   | 185338                        | 185338                     | 185338                   | 185337                          | 185337                     | 185337                   | 185338                        | 185338                     | 185338                   |
| 2        | Volute Gasket                              | P57700                          | P57700                     | P57700                   | P57700                        | P57700                     | P57700                   | P57700                          | P57700                     | P57700                   | P57700                        | P57700                     | P57700                   |
| 17       | Cover Plate                                | P57246                          | P57246                     | P57246                   | P57246                        | P57246                     | P57246                   | P57248                          | P57248                     | P57248                   | P57248                        | P57248                     | P57248                   |
| 26       | Coupler Cover                              | P03982                          | P03982                     | P03982                   | P03982                        | P03982                     | P03982                   | P03982                          | P03982                     | P03982                   | P03982                        | P03982                     | P03982                   |

<sup>1</sup>Buna/Carbon/Ceramic    <sup>2</sup>EPT/Carbon/Tungsten Carbide    <sup>3</sup>Viton/Carbon/Ceramic    CF-Consult Factory

\*includes pre-assembled shaft, sleeve and bearings. Wave spring and volute gasket are also supplied.

## ITEM NO. 5 COUPLERS

See chart on page 23

## ITEM NO. 6 POWER PACKS

| HP | 1 PHASE<br>115/208-230 | 3 PHASE<br>208-230/460 | RING<br>MOUNTS |
|----|------------------------|------------------------|----------------|
| ¾  | 169230                 | 169231                 | 118228         |
| 1  | 169232                 | 169233                 | 118848         |
| 1½ | 169236                 | 169237                 | NONE           |
| 2  | NONE                   | 169238                 | NONE           |
| 3  | NONE                   | 169234                 | NONE           |

— Factory recommended spare parts.

Note: Refer to page 4 for exploded view of pump.

# PARTS FOR MAINTENANCE FREE SERIES 60

| ITEM NO. 5 COUPLERS  |                 |                  |                  |                  |                  |                            |
|--|-----------------|------------------|------------------|------------------|------------------|----------------------------|
| PUMP MODEL   | PUMP SHAFT SIZE | MOTOR HP (60 hz) | MOTOR FRAME SIZE | MOTOR SHAFT SIZE | STANDARD COUPLER | ELASTOMERIC COUPLER OPTION |
| 1x1x5¼<br>1¼x1¼x5¼<br>1½x1½x5¼<br>1½x1½x6¼<br>2x2x5¼<br>2x2x6¼<br>3x3x5¼ | 1/2"            | ¼ - ½            | B&G POWER PACK   | ½"               | 118473           | 185329                     |
|  |                 | ¾ - 1            |                  |                  | 185329           | 185329                     |
|  |                 | ¼ - 1½           | 56               | 5/8"             | 185330           | 185330                     |
|  |                 | 1½               | 56C              | 5/8"             | P75421           | P75421                     |
|  |                 | 1½               | 143TC            | 7/8"             | P75422           | P75422                     |
|  |                 | 1 - 1½           | 143 /145         | 7/8"             | P58598           | P58598                     |
| 1½x1½x7<br>2x2x7   | 5/8"            | ¾                | B&G POWER PACK   | ½"               | 186410           | 185330                     |
|  |                 | 1                |                  |                  | 185330           | 185330                     |
|  |                 | ¾ - 1            | 56               | 5/8"             | 186004           | 186004                     |
|  |                 | 1½ - 3           | 56               | 5/8"             | 186003           | 186003                     |
|  |                 | 1½ - 3           | 143 /145         | 7/8"             | 185331           | 185331                     |
|  |                 | 3                | 182 /184         | 1-1/8"           | P77281           | P77281                     |

■ — Factory recommended spare parts.  
 Note: Refer to page 4 for exploded view of pump.

# How to Select Parts for Series 60 & 1522 Pumps on Pages 25-34

The pump nameplate identifies the pump by model number, pump construction and impeller diameter as shown below.

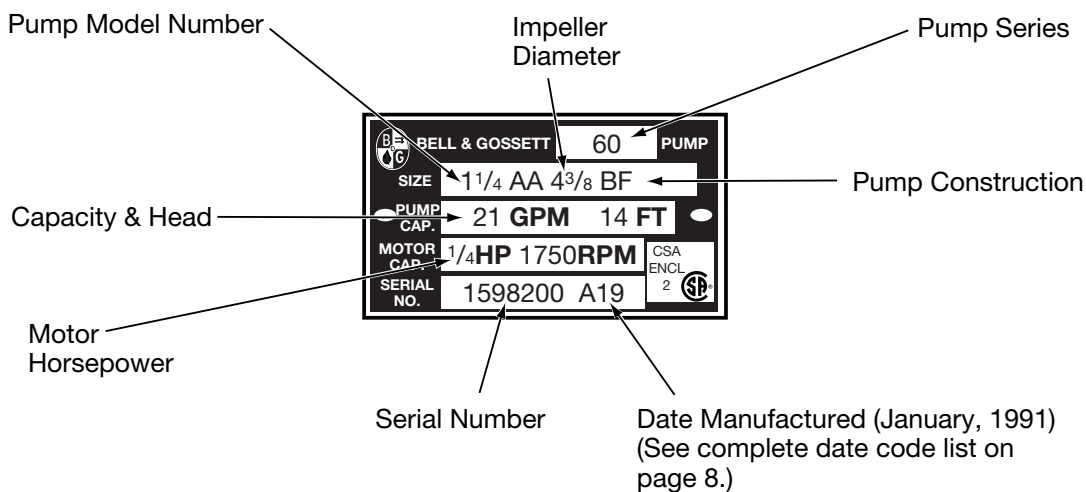

The nameplate above identifies the pump as a Series 60, size 1<sup>1</sup>/<sub>4</sub>AA in bronze-fitted (BF) construction. The impeller diameter is 4<sup>3</sup>/<sub>8</sub>" and is capable of pumping 21 GPM at 14 FT. The motor horsepower is 1/4, the RPM is 1750. The serial number specifically identifies the unit for future reference. **DO NOT REMOVE THE NAMEPLATE.** It is important when ordering replacement parts to furnish complete nameplate data.

Following the procedure below will result in proper parts selection.

1. Determine from the nameplate the model number, pump construction and impeller diameter.
2. Refer to the index for the page number of the parts breakdown for the specific model pump.
3. Find the proper column in the parts breakdown for the pump construction involved.
4. Select part numbers using the numbered drawings on pages 5, 6 & 7 for identification.



# PARTS FOR SERIES 60 PUMPS STANDARD SIZE DESIGNATIONS

|                       |                    |       | (6) SLEEVE BEARING<br>POWER PACK |                        | (5)     |                      | (8)      |
|-----------------------|--------------------|-------|----------------------------------|------------------------|---------|----------------------|----------|
| STANDARD<br>PUMP SIZE | EQUIVALENT<br>SIZE | HP    | 1 PHASE<br>115/230               | 3 PHASE<br>208-230/460 | COUPLER | IMPELLER<br>DIAMETER | IMPELLER |
| 60-1S & 60-1T         | 1"AA               | 1/4   | 169035+                          | 169037                 | 118473  | 5¼"                  | 186359   |
| 60-2S & 60-2T         | 1¼"AA              | 1/3   | 169038                           | 169039                 | 118473  | 5¼"                  | 186359   |
| 60-3S & 60-3T         | 1½"AA              | 1/2   | 111044                           | 111046                 | 118473  | 5¼"                  | 186368   |
| 60-4S & 60-4T         | 2"AA               | 3/4   | 111047                           | 111049                 | 118473  | 5¼"                  | 118626   |
| 60-5S & 60-5T         | 1½"A               | 1/2   | 111044                           | 111046                 | 186410  | 5¾"                  | P57447   |
| 60-6S & 60-6T         | 1½"A               | 3/4   | 111047                           | 111049                 | 186410  | 6½"                  | P57445*  |
| 60-7S & 60-7T         | 1½"A               | 1     | N/A                              | N/A                    | 186004  | 7"                   | P57445   |
| 60-8S & 60-8T         | 2"A                | 3/4   | 111047                           | 111049                 | 186410  | 5⅝"                  | P57452*  |
| 60-9S & 60-9T         | 2"A                | 1     | N/A                              | N/A                    | 186004  | 6⅛"                  | P57451*  |
| 60-10T                | 2"A                | 1-1/2 | -                                | N/A                    | 186003  | 6¾"                  | P57450*  |
| 60-10S                | 1"AA               | 1/4   | 169035+                          | -                      | 118473  | 5¼"                  | 186359   |
| 60-11S & 60-11T       | 1¼"AA              | 1/4   | 169035+                          | 169037                 | 118473  | 5⅜"                  | 186360   |
| 60-B11S               | 1¼"AA              | 1/4   | 169035+                          | -                      | 118473  | 5⅜"                  | 186360   |
| 60-13S & 60-13T       | 1½"AA              | 1/2   | 111044                           | 111046                 | 118473  | 5¼"                  | 186368   |
| 60-B13S & 60-B13T     | 1½"AA              | 1/2   | 111044                           | 111046                 | 118473  | 5¼"                  | 186368   |
| 60-14S & 60-14T       | 2"AA               | 3/4   | 111047                           | 111049                 | 118473  | 5¼"                  | 118626   |
| 60-B14S & 60-B14T     | 2"AA               | 3/4   | 111047                           | 111049                 | 118473  | 5¼"                  | 118626   |
| 60-15S & 60-15T       | 1½"A               | 1/2   | 111044                           | 111046                 | 186410  | 5¾"                  | P57447   |
| 60-16S & 60-16T       | 1½"A               | 3/4   | 111047                           | 111049                 | 186410  | 6⅜"                  | P57446   |
| 60-17S & 60-17T       | 1½"A               | 1     | N/A                              | N/A                    | 186004  | 7"                   | P57445   |
| 60-19S & 60-19T       | 2"A                | 1     | N/A                              | N/A                    | 186004  | 6"                   | P57452   |
| 60-20S & 60-20T       | 2"A                | 1-1/2 | N/A                              | N/A                    | 186003  | 6½"                  | P57451   |
| 60-21T                | 2"A                | 2     | -                                | N/A                    | 186003  | 7"                   | P57450   |
| 60-22T                | 2½"F               | 3     | -                                | 169221                 | P77279  | 7¾"                  | P57584   |

+ 115V only. For 230V, use 169036.

\* Trim impeller to diameter shown.

N/A – No longer available. See note below.

— Factory recommended spare parts.

NOTE: Sleeve bearing power packs and maintenance-free ball bearing power packs are interchangeable. Refer to the Power Pack Cross Reference chart on page 30.

Refer to pages 5 & 7 for exploded views of pump and bearing assembly.

# PARTS FOR SERIES 60

## 1AA

| ITEM NO. | DESCRIPTION                            | BRONZE FITTED | ALL BRONZE | ALL IRON |
|----------|--|---------------|------------|----------|
| 1        | Volute                                 | 186384        | 186385     | 186384   |
| 10       | Volute Pipe Plug (5 Required)          | P39020        | P39470     | P39020   |
| 7        | Volute Capscrew (8 Required)           | P10620        | P01850     | P10620   |
| 8        | Impeller (State Diameter)              | P56550        | P56550     | P60350*  |
|          | Flange (2)                             | P01510        | P00836     | P01510   |
|          | Fastener Package w/ Flange Gaskets     | P64910        | P64900     | P64910   |
|          | Flange Gasket Set                      | 118368        | 118368     | 118368   |
| 4        | Sleeve Bearing Assembly Consisting of: | 186863        | 186863     | 186865   |
| 13       | Bearing Bracket                        | P77179        | P77179     | P77179   |
| 14       | Front Bearing                          | P77216        | P77216     | P77215   |
| 15       | Front Bearing Gasket                   | P80816        | P80816     | P80816   |
| 21       | Shaft Assembly                         | 189035        | 189035     | P81960   |
| 11       | Seal Kit                               | 118681        | 118681     | 186681   |
| 2        | Body Gasket                            | P57410        | P57410     | P57410   |
|          | Impeller Key                           | P04940        | P04940     | P04940   |
| 9        | Impeller Nut                           | P44200        | P44200     | P04670   |
| 3        | Impeller Washer                        | P57000        | P57000     | P04650   |
| 12       | Oil Well Cover                         | P81239        | P81239     | P81239   |
| 19       | Oil Wick Set                           | 118395        | 118395     | 118395   |

## 1¼AA

| ITEM NO. | DESCRIPTION                            | BRONZE FITTED | ALL BRONZE | ALL IRON |
|----------|--|---------------|------------|----------|
| 1        | Volute                                 | 186386        | 186931     | 186386   |
| 10       | Volute Pipe Plug (5 Required)          | P39020        | P39470     | P39020   |
| 7        | Volute Capscrew (8 Required)           | P10620        | P01850     | P10620   |
| 8        | Impeller (State Diameter)              | P56550        | P56550     | P60350*  |
|          | Flange (2 Required)                    | P03250        | P00837     | P03250   |
|          | Fastener Package w/ Flange Gaskets     | P64910        | P64900     | P64910   |
|          | Flange Gasket Set                      | 118368        | 118368     | 118368   |
| 4        | Sleeve Bearing Assembly Consisting of: | 186863        | 186863     | 186865   |
| 13       | Bearing Bracket                        | P77179        | P77179     | P77179   |
| 14       | Front Bearing                          | P77216        | P77216     | P77215   |
| 15       | Front Bearing Gasket                   | P80816        | P80816     | P80816   |
| 21       | Shaft Assembly                         | 189035        | 189035     | P81960   |
| 11       | Seal Kit                               | 118681        | 118681     | 186681   |
| 2        | Body Gasket                            | P57410        | P57410     | P57410   |
|          | Impeller Key                           | P04940        | P04940     | P04940   |
| 9        | Impeller Nut                           | P44200        | P44200     | P04670   |
| 3        | Impeller Washer                        | P57000        | P57000     | P04650   |
| 12       | Oil Well Cover                         | P81239        | P81239     | P81239   |
| 19       | Oil Wick Set                           | 118395        | 118395     | 118395   |

## COUPLER SELECTION

| ITEM NO. | PUMP SHAFT SIZE | HP | FRAME SIZE | MOTOR SHAFT SIZE | STANDARD COUPLER | EXPLOSION PROOF COUPLER |
|----------|-----------------|----|------------|------------------|------------------|-------------------------|
| 5        | 1/2"            | -  | B&G        | 1/2"             | 118473           | P77234                  |
| 5        | 1/2"            | -  | 56         | 5/8"             | 118709           | 118635                  |

## SLEEVE BEARING POWER PACK SELECTION

See Chart on page 30

— Factory recommended spare parts.

\* Steel Impeller.

Note: Refer to pages 5 & 7 for exploded views of pump and bearing assembly.

# PARTS FOR SERIES 60

## 1½AA

| ITEM NO. | DESCRIPTION                            | BRONZE FITTED | ALL BRONZE | ALL IRON |
|----------|--|---------------|------------|----------|
| 1        | Volute                                 | 186389        | 186932     | 186389   |
| 10       | Volute Pipe Plug (5 Required)          | P39020        | P39470     | P39020   |
| 7        | Volute Capscrew (8 Required)           | P10620        | P01850     | P10620   |
| 8        | Impeller (State Diameter)              | P56740        | P56740     | P61010*  |
|          | Flange (2 Required)                    | P03410        | P06690     | P03410   |
|          | Fastener Package w/ Flange Gaskets     | P64940        | P64930     | P64940   |
|          | Flange Gasket Set                      | 118373        | 118373     | 118373   |
| 4        | Sleeve Bearing Assembly Consisting of: | 186863        | 186863     | 186865   |
| 13       | Bearing Bracket                        | P77179        | P77179     | P77179   |
| 14       | Front Bearing                          | P77216        | P77216     | P77215   |
| 15       | Front Bearing Gasket                   | P80816        | P80816     | P80816   |
| 21       | Shaft Assembly                         | 189035        | 189035     | P81960   |
| 11       | Seal Kit                               | 118681        | 118681     | 186681   |
| 2        | Body Gasket                            | P57410        | P57410     | P57410   |
|          | Impeller Key                           | P04940        | P04940     | P04940   |
| 9        | Impeller Nut                           | P44200        | P44200     | P04670   |
| 3        | Impeller Washer                        | P57000        | P57000     | P04650   |
| 12       | Oil Well Cover                         | P81239        | P81239     | P81239   |
| 19       | Oil Wick Set                           | 118395        | 118395     | 118395   |

## 2AA

| ITEM NO. | DESCRIPTION                                    | BRONZE FITTED | ALL BRONZE | ALL IRON |
|----------|--|---------------|------------|----------|
| 1        | Volute   | 186392        | 186933     | 186392   |
| 10       | Volute Pipe Plug (5 Required)                  | P39020        | P39470     | P39020   |
| 7        | Volute Capscrew (8 Required)                   | P10620        | P01850     | P10620   |
| 8        | Impeller (State Diameter)                      | P56810        | P56810     | P61550*  |
|          | Flange (2 Required)                            | F14200        | F54200     | F14200   |
|          | Fastener Package w/ Flange Gasket (2 Required) | P65030        | P65031     | P65030   |
|          | Flange Gasket Set                              | 118378        | 118378     | 118378   |
| 4        | Sleeve Bearing Assembly Consisting of:         | 186863        | 186863     | 186865   |
| 13       | Bearing Bracket                                | P77179        | P77179     | P77179   |
| 14       | Front Bearing                                  | P77216        | P77216     | P77215   |
| 15       | Front Bearing Gasket                           | P80816        | P80816     | P80816   |
| 21       | Shaft Assembly                                 | 189035        | 189035     | P81960   |
| 11       | Seal Kit                                       | 118681        | 118681     | 186681   |
| 2        | Body Gasket                                    | P57410        | P57410     | P57410   |
|          | Impeller Key                                   | P04940        | P04940     | P04940   |
| 9        | Impeller Nut                                   | P44200        | P44200     | P04670   |
| 3        | Impeller Washer                                | P57000        | P57000     | P04650   |
| 12       | Oil Well Cover                                 | P81239        | P81239     | P81239   |
| 19       | Oil Wick Set                                   | 118395        | 118395     | 118395   |

## COUPLER SELECTION

| ITEM NO. | PUMP SHAFT SIZE | HP | FRAME SIZE | MOTOR SHAFT SIZE | STANDARD COUPLER | EXPLOSION PROOF COUPLER |
|----------|-----------------|----|------------|------------------|------------------|-------------------------|
| 5        | 1/2"            | -  | B&G        | 1/2"             | 118473**         | P77234                  |
| 5        | 1/2"            | -  | 56         | 5/8"             | 118709           | 118635                  |

\*\* Use 185329 sleeve-type coupler with 3/4 HP maintenance free ball bearing motor

## SLEEVE BEARING POWER PACK SELECTION

*See Chart on page 30*

— Factory recommended spare parts.

\* Steel Impeller.

Note: Refer to pages 5 & 7 for exploded views of pump and bearing assembly.

## 1½A

**PARTS FOR SERIES 60**

| ITEM NO. | DESCRIPTION                            | BRONZE FITTED | ALL BRONZE | ALL IRON |
|----------|--|---------------|------------|----------|
| 1        | Volute                                 | 186390        | 186934     | 186390   |
| 10       | Volute Pipe Plug (5 Required)          | P39020        | P39470     | P39020   |
| 7        | Volute Capscrew (8 Required)           | P40020        | P52310     | P40020   |
| 8        | Impeller (State Diameter)              | P57445        | P57445     | P57500   |
|          | Flange (2 Required)                    | P03410        | P06690     | P03410   |
|          | Fastener Package w/ Flange Gaskets     | P64940        | P64930     | P64940   |
|          | Flange Gasket Set                      | 118373        | 118373     | 118373   |
| 4        | Sleeve Bearing Assembly Consisting of: | 185260        | 185262     | 185261   |
| 13       | Bearing Bracket                        | P57282        | P57282     | P57282   |
| 17       | Coverplate                             | P57246        | P57248     | P57246   |
| 14       | Front Bearing*                         | 185241        | 185241     | 185241   |
| 16       | Rear Bearing                           | 185240        | 185240     | 185240   |
| 21       | Shaft Assembly                         | 118469        | 118469     | P08725   |
|          | Coupler Key                            | H32400        | H32400     | H32400   |
| 11       | Seal Kit                               | 186499        | 186499     | 186433   |
| 2        | Body Gasket                            | P57700        | P57700     | P57700   |
|          | Impeller Key                           | P49358        | P49358     | P49358   |
| 9        | Impeller Nut                           | P45910        | P08480     | P45910   |
| 3        | Impeller Washer                        | P11150        | P11220     | P11150   |
| 12       | Oil Well Cover                         | P57302        | P57302     | P57302   |
| 18       | Oil Well Gasket                        | P57300        | P57300     | P57300   |
| 19       | Oil Wick (2 Required)                  | P04883        | P04883     | P04883   |
| 20       | Oil Wick Retainer (2 Required)         | P12422        | P12422     | P12422   |

## 2A

| ITEM NO. | DESCRIPTION                                    | BRONZE FITTED | ALL BRONZE | ALL IRON |
|----------|--|---------------|------------|----------|
| 1        | Volute   | 186937        | 186938     | 186937   |
| 10       | Volute Pipe Plug (5 Required)                  | P39020        | P39470     | P39020   |
| 7        | Volute Capscrew (8 Required)                   | P40020        | P52310     | P40020   |
| 8        | Impeller (State Diameter)                      | P57450        | P57450     | N/A      |
|          | Flange (2 Required)                            | F14200        | F54200     | F14200   |
|          | Fastener Package w/ Flange Gasket (2 Required) | P65030        | P65031     | P65030   |
|          | Flange Gasket Set                              | 118378        | 118378     | 118378   |
| 4        | Sleeve Bearing Assembly Consisting of:         | 185260        | 185262     | 185261   |
| 13       | Bearing Bracket                                | P57282        | P57282     | P57282   |
| 17       | Coverplate                                     | P57246        | P57248     | P57246   |
| 14       | Front Bearing*                                 | 185241        | 185241     | 185241   |
| 16       | Rear Bearing                                   | 185240        | 185240     | 185240   |
| 21       | Shaft Assembly                                 | 118469        | 118469     | P08725   |
|          | Coupler Key                                    | H32400        | H32400     | H32400   |
| 11       | Seal Kit                                       | 186499        | 186499     | 186433   |
| 2        | Body Gasket                                    | P57700        | P57700     | P57700   |
|          | Impeller Key                                   | P49358        | P49358     | P49358   |
| 9        | Impeller Nut                                   | P45910        | P08480     | P45910   |
| 3        | Impeller Washer                                | P11150        | P11220     | P11150   |
| 12       | Oil Well Cover                                 | P57302        | P57302     | P57302   |
| 18       | Oil Well Gasket                                | P57300        | P57300     | P57300   |
| 19       | Oil Wick (2 Required)                          | P04883        | P04883     | P04883   |
| 20       | Oil Wick Retainer (2 Required)                 | P12422        | P12422     | P12422   |

**COUPLER SELECTION**

| ITEM NO. | PUMP SHAFT SIZE | HP       | FRAME SIZE | MOTOR SHAFT SIZE | STANDARD COUPLER | EXPLOSION PROOF COUPLER |
|----------|-----------------|----------|------------|------------------|------------------|-------------------------|
| 5        | 5/8"            | 1/2, 3/4 | B&G        | 1/2"             | 186410           | P77237                  |
| 5        | 5/8"            | 1        | 56         | 5/8"             | 186004           | 186004                  |
| 5        | 5/8"            | 1        | 143TZ      | 5/8"             | 186004           | 186004                  |
| 5        | 5/8"            | 1-1/2, 2 | 56         | 5/8"             | 186003           | 186003                  |
| 5        | 5/8"            | 1-1/2, 2 | 145TZ      | 5/8"             | 186003           | 186003                  |

**SLEEVE BEARING POWER PACK SELECTION**

See Chart on page 30

— Factory recommended spare parts.

\* Includes P57303 Lip Seal.

Note: Refer to pages 5 & 7 for exploded views of pump and bearing assembly.

# PARTS FOR SERIES 60

**2½F**

| ITEM NO. | DESCRIPTION                            | BRONZE FITTED | ALL BRONZE | ALL IRON      |
|----------|--|---------------|------------|---------------|
| 1        | Volute                                 | P57232        | P57234     | NOT AVAILABLE |
| 10       | Volute Pipe Plug (5 Required)          | P39040        | P39480     |               |
| 7        | Volute Capscrew (12 Required)          | P03470        | S04180     |               |
| 8        | Impeller (State Diameter)              | P57583        | P57583     |               |
| 4        | Sleeve Bearing Assembly Consisting of: | 185264        | 185265     |               |
| 13       | Bearing Bracket                        | P57282        | P57282     |               |
| 17       | Coverplate                             | P57242        | P57244     |               |
| 14       | Front Bearing*                         | 185241        | 185241     |               |
| 16       | Rear Bearing                           | 185240        | 185240     |               |
| 21       | Shaft Assembly                         | 118469        | 118469     |               |
|          | Coupler Key                            | H32400        | H32400     |               |
| 11       | Seal Kit                               | 186499        | 186499     |               |
| 2        | Body Gasket                            | P57701        | P57701     |               |
|          | Impeller Key                           | P49358        | P49358     |               |
| 9        | Impeller Nut                           | P45910        | P08480     |               |
| 3        | Impeller Washer                        | P11150        | P11220     |               |
| 12       | Oil Well Cover                         | P57302        | P57302     |               |
| 18       | Oil Well Gasket                        | P57300        | P57300     |               |
| 19       | Oil Wick (2 Required)                  | P04883        | P04883     |               |
| 20       | Oil Wick Retainer (2 Required)         | P12422        | P12422     |               |

## COUPLER SELECTION

| ITEM NO. | PUMP SHAFT SIZE | HP       | FRAME SIZE | MOTOR SHAFT SIZE | STANDARD | EXPLOSION     |
|----------|-----------------|----------|------------|------------------|----------|---------------|
|          |                 |          |            |                  | COUPLER  | PROOF COUPLER |
| 5        | 5/8"            | 1-1/2, 2 | 145TZ      | 5/8"             | 186003   | 186003        |
| 5        | 5/8"            | 3        | 145TC      | 7/8"             | P77279   | P77279        |
| 5        | 5/8"            | 3        | 182TC      | 1-1/8"           | P77281   | P77281        |

## SLEEVE BEARING POWER PACK SELECTION

*See Chart on page 30*

— Factory recommended spare parts.

\* Includes P57303 Lip Seal.

Note: Refer to pages 5 & 7 for exploded views of pump and bearing assembly.

# POWER PACK SELECTION FOR SERIES 60 & PD PUMPS

## SLEEVE BEARING POWER PACK SELECTION

| ITEM NO. | HP    | 1 PHASE  | 3 PHASE         | RING MOUNTS |
|----------|-------|----------|-----------------|-------------|
|          |       | 115/230V | 208-230/460V    |             |
| 6        | 1/4   | 169035*  | 169037          | 118228      |
| 6        | 1/3   | 169038   | 169039          | 118228      |
| 6        | 1/2   | 111044   | 111046          | 118228      |
| 6        | 3/4   | 111047+  | 111049+         | 118228      |
| 6        | 1     | N/A†     | N/A†            | 118848**    |
| 6        | 1-1/2 | N/A      | N/A             | 118848**    |
| 6        | 2     | -        | N/A             | 118848      |
| 6        | 3     | -        | 169221 (145TC)  | NONE        |
| 6        | 3     | -        | 169223+ (182TC) | NONE        |

\* 115V only. For 230V, use part number 169036.

+For 200V only, use part number 169222.

\*\* For 3 phase only. Motor mounts for single phase power packs not available.

+ When replacing this sleeve bearing motor with the new maintenance free ball bearing motor, the 118473 spring-type coupler must be changed to the 185329 sleeve-type coupler.

† When replacing this old sleeve bearing motor with the new maintenance free ball bearing motor, the 5/8" x 5/8" coupler part number 186004 must be changed to the 5/8" x 1/2" coupler part number 185330.

**NOTE: Sleeve bearing power packs and maintenance-free ball bearing power packs are interchangeable.**

When replacing a sleeve bearing power pack with a ball bearing power pack, the old motor bracket must be removed from the pump and discarded. The ball bearing power pack is bolted directly to the bearing assembly.

## POWER PACK CROSS REFERENCE

| HP    | PH | SLEEVE BEARING |              |                    | MAINTENANCE-FREE BALL BEARING |              |                     |
|-------|----|----------------|--------------|--------------------|-------------------------------|--------------|---------------------|
|       |    | VOLTAGE        | MOTOR MOUNTS | POWER PACK PART NO | VOLTAGE                       | MOTOR MOUNTS | POWER PACK PART NO. |
| 1/4   | 1  | 115/230        | 118228       | 169035/169036      | 115/208-230                   | 118228       | 169224              |
| 1/4   | 3  | 208-230/460    | 118228       | 169037             | 208-230/460                   | 118228       | 169225              |
| 1/3   | 1  | 115/230        | 118228       | 169038             | 115/208-230                   | 118228       | 169226              |
| 1/3   | 3  | 208-230/460    | 118228       | 169039             | 208-230/460                   | 118228       | 169227              |
| 1/2   | 1  | 115/230        | 118228       | 111044             | 115/208-230                   | 118228       | 169228              |
| 1/2   | 3  | 208-230/460    | 118228       | 111046             | 208-230/460                   | 118228       | 169229              |
| 3/4   | 1  | 115/230        | 118228       | 111047             | 115/208-230                   | 118228       | 169230              |
| 3/4   | 3  | 208-230/460    | 118228       | 111049             | 208-230/460                   | 118228       | 169231              |
| 1     | 1  | 115/230        | N/A          | N/A                | 115/208-230                   | 118848       | 169232              |
| 1     | 3  | 208-230/460    | 118848       | N/A                | 208-230/460                   | 118848       | 169233              |
| 1-1/2 | 1  | 115/230        | N/A          | N/A                | 115/208-230                   | NONE         | 169236              |
| 1-1/2 | 3  | 208-230/460    | 118848       | N/A                | 208-230/460                   | NONE         | 169237              |
| 2     | 3  | 208-230/460    | 118848       | N/A                | 208-230/460                   | NONE         | 169238              |
| 3     | 3  | 208-230/460    | NONE         | 169221             | 208-230/460                   | NONE         | 169234              |

N/A – No Longer Available

 – Factory recommended spare parts.

Note: Refer to page 5 for exploded view of pump.

# BEARING ASSEMBLY SELECTION FOR SERIES 60 & PD PUMPS

## BEARING ASSEMBLY CROSS REFERENCE

| SLEEVE BEARING              |              |                           | XL-11™ BEARING            |       |
|-----------------------------|--------------|---------------------------|---------------------------|-------|
| PUMP SIZE                   | PUMP TYPE    | BEARING ASSEMBLY PART NO. | BEARING ASSEMBLY PART NO. | SIZE  |
| PD-35, PD-37, 60 "AA"       | IB, BF or AB | 186863                    | 185332*                   | SMALL |
| PD-38, PD-39, PD-40, 60 "A" | IB or BF     | 185260                    | 185333**                  | LARGE |
| PD-38, PD-39, PD-40, 60 "A" | AB           | 185262                    | 185334**                  | LARGE |
| 60 "F"                      | BF           | 185264                    | N/A                       | N/A   |
| 60 "F"                      | AB           | 185265                    | N/A                       | N/A   |

**NOTE: Sleeve bearing assemblies and XL-11 bearing assemblies are interchangeable.**

\* The 185332 Bearing Assembly is 5/8" longer than the AA sleeve bearing frame

\*\* When replacing a sleeve bearing assembly (oil-lubricated) with a new XL-11 bearing assembly on the larger PD's and 60 "A" size pumps that have the original factory-installed 7" power pack, an adapter kit is required.

## ADAPTER KIT FOR XL-11™ MAINTENANCE-FREE BEARING RETROFIT

| MOTOR HP | MOTOR PHASE | ADAPTER KIT PART NUMBER |
|----------|-------------|-------------------------|
| 1        | 1           | 185350                  |
| 1        | 3           | 185351                  |
| 1-1/2    | 1           | 185352                  |
| 1-1/2    | 3           | 185353                  |
| 2        | 3           | 185354                  |

## XL-11™ BEARING ASSEMBLIES

| ITEM NO. | DESCRIPTION                      | SMALL  | LARGE  |        |
|----------|----------------------------------|--------|--------|--------|
|          |                                  | 185332 | 185333 | 185334 |
| 11       | Seal Kit                         | 118681 | 186499 | 186499 |
|          | XL-11™ Bearing Frame Repair Kit* | 185335 | 185337 | 185337 |
| 2        | Volute Gasket                    | P57410 | P57700 | P57700 |
| 12       | Coverplate                       | NONE   | P57246 | P57248 |
|          | Coupler Cover                    | NONE   | P03982 | P03982 |

\* Includes pre-assembled shaft, sleeve and bearings, wave spring and volute gasket.

— Factory recommended spare parts.

## PARTS FOR SERIES 1522 STANDARD SIZE DESIGNATIONS

| ITEM NO.  |             |                                |       | (6)             | (6)              |      | (8)      |                   | (5)     |
|-----------|-------------|--------------------------------|-------|-----------------|------------------|------|----------|-------------------|---------|
| PUMP SIZE | PART NUMBER | BUILT-TO-ORDER EQUIVALENT SIZE | HP    | 1 PHASE 115/230 | 3 PHASE TRI VOLT | RPM  | IMPELLER | IMPELLER DIAMETER | COUPLER |
| 1S-1      | 173014      | 3/4"AAB                        | 1/4   | 169040+         | -                | 1750 | 186359   | 5-1/4"            | 118473  |
| 1T-1      | 173057      | 3/4"AAB                        | 1/4   | -               | 169042           | 1750 | 186359   | 5-1/4"            | 118473  |
| 2S-1      | 173078      | 1"AAB                          | 1/3   | 169043          | -                | 1750 | 186359   | 5-1/4"            | 118473  |
| 2T-1      | 173079      | 1"AAB                          | 1/3   | -               | 169045           | 1750 | 186359   | 5-1/4"            | 118473  |
| 3S-1      | 173080      | 1-1/4"AAB                      | 1/2   | 169047          | -                | 1750 | 186368   | 5-1/4"            | 118473  |
| 3T-1      | 173081      | 1-1/4"AAB                      | 1/2   | -               | 169049           | 1750 | 186368   | 5-1/4"            | 118473  |
| 4S        | 173082      | 1-1/2" AAB                     | 3/4   | 169051          | -                | 1750 | 118626   | 5-1/4"            | 118473  |
| 4T        | 173083      | 1-1/2" AAB                     | 3/4   | -               | 169053           | 1750 | 118626   | 5-1/4"            | 118473  |
| 5S-1      | Obsolete    | 3/4"AAB                        | 1/2   | 169048          | -                | 3450 | 186363   | 4"                | 118709  |
| 5T-1      | Obsolete    | 3/4"AAB                        | 1/2   | -               | 169050           | 3450 | 186363   | 4"                | 118709  |
| 6S-1      | Obsolete    | 1"AAB                          | 3/4   | 169052          | -                | 3450 | 186366   | 3-7/8"            | 118709  |
| 6T-1      | Obsolete    | 1"AAB                          | 3/4   | -               | 169054           | 3450 | 186366   | 3-7/8"            | 118709  |
| 7S-1      | Obsolete    | 3/4"AAB                        | 3/4   | 169052          | -                | 3450 | 186362   | 4-3/8"            | 118709  |
| 7T-1      | Obsolete    | 3/4"AAB                        | 3/4   | -               | 169054           | 3450 | 186362   | 4-3/8"            | 118709  |
| 8S-1      | Obsolete    | 1-1/4"AAB                      | 1     | 169055          | -                | 3450 | 186371   | 3-5/8"            | 118709  |
| 8T-1      | Obsolete    | 1-1/4"AAB                      | 1     | -               | 169056           | 3450 | 186371   | 3-5/8"            | 118709  |
| 9S-1      | Obsolete    | 3/4"AAB                        | 1-1/2 | 169057          | -                | 3450 | 186360   | 5-3/16"           | 118709  |
| 9T-1      | Obsolete    | 3/4"AAB                        | 1-1/2 | -               | 169058           | 3450 | 186360   | 5-3/16"           | 118709  |
| 11T       | Obsolete    | 1-1/2" AAB                     | 2     | -               | 169060           | 3450 | 186373   | 3-15/16"          | 118709  |
| 12S-1     | Obsolete    | 3/4"AAB                        | 1     | 169055          | -                | 3450 | 186361   | 4-11/16"          | 118709  |
| 12T-1     | Obsolete    | 3/4"AAB                        | 1     | -               | 169056           | 3450 | 186361   | 4-11/16"          | 118709  |
| 14S       | Obsolete    | 3/4"AAB                        | 1/3   | 169044          | -                | 3450 | 186364   | 3-7/16"           | 118709  |
| 14T       | Obsolete    | 3/4"AAB                        | 1/3   | -               | 169046           | 3450 | 186364   | 3-7/16"           | 118709  |
| 15T-1     | Obsolete    | 1"AAB                          | 2     | -               | 169060           | 3450 | 186359   | 5-1/4"            | 118709  |
| 16S-1     | Obsolete    | 1-1/4"AAB                      | 1-1/2 | 169057          | -                | 3450 | 186370   | 4-1/8"            | 118709  |
| 16T-1     | Obsolete    | 1-1/4"AAB                      | 1-1/2 | -               | 169058           | 3450 | 186370   | 4-1/8"            | 118709  |
| 17S       | Obsolete    | 1-1/2" AAB                     | 1-1/2 | 169057          | -                | 3450 | 186375   | 3-11/16"          | 118709  |
| 17T       | Obsolete    | 1-1/2" AAB                     | 1-1/2 | -               | 169058           | 3450 | 186375   | 3-11/16"          | 118709  |

+115V. For 230V, use 169041.

- Factory recommended spare parts.

Note: Refer to pages 6 & 7 for exploded views of pump and bearing assembly.



# PARTS FOR SERIES 1522

## 3/4AAB

| ITEM NO. | DESCRIPTION                     | BRONZE FITTED | ALL BRONZE | ALL IRON | SS▼    | BFE      |
|----------|---------------------------------|---------------|------------|----------|--------|----------|
| 1        | Volute                          | 186074        | 186333     | 186074   | N/A    | 186074   |
| 10       | Volute Drain Plug (4 Req'd)     | P39020        | P39470     | P39020   | P39030 | P39020   |
| 7        | Volute Capscrew (8 Req'd)       | P10620        | P01850     | P10620   | P00660 | P10620   |
| 8        | Impeller (State Diameter)       | P56550        | P56550     | P60350*  | N/A    | P56550   |
| 4        | Bearing Assembly Consisting of: | 186863        | 186863     | 186865   | N/A    | P10316** |
| 13       | Bearing Bracket                 | P77179        | P77179     | P77179   | P77198 | P77179   |
| 14       | Front Bearing                   | P77216        | P77216     | P77215   | P77217 | P77216   |
| 15       | Front Bearing Gasket            | P80816        | P80816     | P80816   | P80816 | P80816   |
| 21       | Shaft                           | 189035        | 189035     | P81960   | N/A    | 189035   |
| 11       | Seal                            | 118681        | 118681     | 186681   | 186875 | 185230   |
| 2        | Body Gasket                     | P57410        | P57410     | P57410   | P57410 | P57410   |
|          | Impeller Key                    | P04940        | P04940     | P04940   | P04945 | P04940   |
| 9        | Impeller Nut                    | P44200        | P44200     | P04670   | P00651 | P44200   |
| 3        | Impeller Washer                 | P57000        | P57000     | P04650   | P04660 | P57000   |
| 12       | Oil Well Cover                  | P81239        | P81239     | P81239   | P81239 | P81239   |
| 19       | Oil Wick Set                    | 118395        | 118395     | 118395   | 118395 | 118395   |
|          | Flat Head Capscrew (4 Req'd)    | NONE          | NONE       | NONE     | P51190 | NONE     |
| 17       | Coverplate                      | NONE          | NONE       | NONE     | P09421 | NONE     |

## 1AAB

| ITEM NO. | DESCRIPTION                     | BRONZE FITTED | ALL BRONZE | ALL IRON | SS▼    | BFE      |
|----------|---------------------------------|---------------|------------|----------|--------|----------|
| 1        | Volute                          | 186075        | P41160     | 186075   | N/A    | 186075   |
| 10       | Volute Drain Plug (4 Req'd)     | P39020        | P39470     | P39020   | P39030 | P39020   |
| 7        | Volute Capscrew (8 Req'd)       | P10620        | P01850     | P10620   | P00660 | P10620   |
| 8        | Impeller (State Diameter)       | P56550        | P56550     | P60350*  | N/A    | P56550   |
| 4        | Bearing Assembly Consisting of: | 186863        | 186863     | 186865   | N/A    | P10316** |
| 13       | Bearing Bracket                 | P77179        | P77179     | P77179   | P77198 | P77179   |
| 14       | Front Bearing                   | P77216        | P77216     | P77215   | P77217 | P77216   |
| 15       | Front Bearing Gasket            | P80816        | P80816     | P80816   | P80816 | P80816   |
| 21       | Shaft                           | 189035        | 189035     | P81960   | N/A    | 189035   |
| 11       | Seal                            | 118681        | 118681     | 186681   | 186875 | 185230   |
| 2        | Body Gasket                     | P57410        | P57410     | P57410   | P57410 | P57410   |
|          | Impeller Key                    | P04940        | P04940     | P04940   | P04945 | P04940   |
| 9        | Impeller Nut                    | P44200        | P44200     | P04670   | P00651 | P44200   |
| 3        | Impeller Washer                 | P57000        | P57000     | P04650   | P04660 | P57000   |
| 12       | Oil Well Cover                  | P81239        | P81239     | P81239   | P81239 | P81239   |
| 19       | Oil Wick Set                    | 118395        | 118395     | 118395   | 118395 | 118395   |
|          | Flat Head Capscrew (4 Req'd)    | NONE          | NONE       | NONE     | P51190 | NONE     |
| 17       | Coverplate                      | NONE          | NONE       | NONE     | P09421 | NONE     |

## COUPLER SELECTION

| ITEM NO. | PUMP SHAFT SIZE | FRAME SIZE | MOTOR SHAFT SIZE | STD COUPLER | EXPLOSION PROOF |
|----------|-----------------|------------|------------------|-------------|-----------------|
| 5        | 1/2"            | B&G        | 1/2"             | 118473      | P77234          |
| 5        | 1/2"            | B&G        | 5/8"             | 118709      | 118635          |
| 5        | 1/2"            | 56         | 5/8"             | 118709      | 118635          |

## POWER PACK SELECTION

| ITEM NO. | HP    | 1 PH, 115/230V<br>1750 RPM | 1 PH, 230/460V<br>3450 RPM ▼ | 3 PH, 208-230/460V<br>1750 RPM | 3 PH, 208-230/460V<br>3450 RPM ▼ | RING MOUNTS |
|----------|-------|----------------------------|------------------------------|--------------------------------|----------------------------------|-------------|
| 6        | 1/4   | 169040+                    | NONE                         | 169042                         | NONE                             | 118228      |
| 6        | 1/3   | 169043                     | 169044                       | 169045                         | 169046                           | 118228      |
| 6        | 1/2   | 169047                     | 169048                       | 169049                         | 169050                           | 118228      |
| 6        | 3/4   | 169051                     | 169052                       | 169053                         | 169054                           | 118228      |
| 6        | 1     | NONE                       | 169055                       | NONE                           | 169056                           | NONE        |
| 6        | 1-1/2 | NONE                       | 169057                       | NONE                           | 169058                           | NONE        |
| 6        | 2     | NONE                       | N/A                          | NONE                           | 169060                           | NONE        |

\*Steel Impeller

\*\*Doesn't include body gasket, impeller nut or impeller washer.

+115V only. For 230V, use 169041

▼ For replacement purposes only. 1522 pumps are no longer available with this option.

N/A – No Longer Available.

— Factory recommended spare parts.

Note: Refer to pages 6 & 7 for exploded views of pump and bearing assembly.

# PARTS FOR SERIES 1522

## 1¼AAB

| ITEM NO. | DESCRIPTION                     | BRONZE FITTED | ALL BRONZE | ALL IRON | SS▼    | BFE      |
|----------|---------------------------------|---------------|------------|----------|--------|----------|
| 1        | Volute                          | 186081        | P41300     | 186081   | N/A    | 186081   |
| 10       | Volute Drain Plug (4 Req'd)     | P39020        | P39470     | P39020   | P39030 | P39020   |
| 7        | Volute Capscrew (8 Req'd)       | P10620        | P01850     | P10620   | P00660 | P10620   |
| 8        | Impeller (State Diameter)       | P56740        | P56740     | P61010*  | N/A    | P56740   |
| 4        | Bearing Assembly Consisting of: | 186863        | 186863     | 186865   | N/A    | P10316** |
| 13       | Bearing Bracket                 | P77179        | P77179     | P77179   | P77198 | P77179   |
| 14       | Front Bearing                   | P77216        | P77216     | P77215   | P77217 | P77216   |
| 15       | Front Bearing Gasket            | P80816        | P80816     | P80816   | P80816 | P80816   |
| 21       | Shaft                           | 189035        | 189035     | P81960   | N/A    | 189035   |
| 11       | Seal                            | 118681        | 118681     | 186681   | 186875 | 185230   |
| 2        | Body Gasket                     | P57410        | P57410     | P57410   | P57410 | P57410   |
|          | Impeller Key                    | P04940        | P04940     | P04940   | P04945 | P04940   |
| 9        | Impeller Nut                    | P44200        | P44200     | P04670   | P00651 | P44200   |
| 3        | Impeller Washer                 | P57000        | P57000     | P04650   | P04660 | P57000   |
| 12       | Oil Well Cover                  | P81239        | P81239     | P81239   | P81239 | P81239   |
| 19       | Oil Wick Set                    | 118395        | 118395     | 118395   | 118395 | 118395   |
|          | Flat Head Capscrew (4 Req'd)    | NONE          | NONE       | NONE     | P51190 | NONE     |
| 17       | Coverplate                      | NONE          | NONE       | NONE     | P09421 | NONE     |

## 1½AAB

| ITEM NO. | DESCRIPTION                     | BRONZE FITTED | ALL BRONZE | ALL IRON | SS▼    | BFE      |
|----------|---------------------------------|---------------|------------|----------|--------|----------|
| 1        | Volute                          | 186087        | 186334     | 186087   | N/A    | 186087   |
| 10       | Volute Drain Plug (4 Req'd)     | P39020        | P39470     | P39020   | P39030 | P39020   |
| 7        | Volute Capscrew (8 Req'd)       | P10620        | P01850     | P10620   | P00660 | P10620   |
| 8        | Impeller (State Diameter)       | P56810        | P56810     | P61550*  | N/A    | P56810   |
| 4        | Bearing Assembly Consisting of: | 186863        | 186863     | 186865   | N/A    | P10316** |
| 13       | Bearing Bracket                 | P77179        | P77179     | P77179   | P77198 | P77179   |
| 14       | Front Bearing                   | P77216        | P77216     | P77215   | P77217 | P77216   |
| 15       | Front Bearing Gasket            | P80816        | P80816     | P80816   | P80816 | P80816   |
| 21       | Shaft                           | 189035        | 189035     | P81960   | N/A    | 189035   |
| 11       | Seal                            | 118681        | 118681     | 186681   | 186875 | 185230   |
| 2        | Body Gasket                     | P57410        | P57410     | P57410   | P57410 | P57410   |
|          | Impeller Key                    | P04940        | P04940     | P04940   | P04945 | P04940   |
| 9        | Impeller Nut                    | P44200        | P44200     | P04670   | P00651 | P44200   |
| 3        | Impeller Washer                 | P57000        | P57000     | P04650   | P04660 | P57000   |
| 12       | Oil Well Cover                  | P81239        | P81239     | P81239   | P81239 | P81239   |
| 19       | Oil Wick Set                    | 118395        | 118395     | 118395   | 118395 | 118395   |
|          | Flat Head Capscrew (4 Req'd)    | NONE          | NONE       | NONE     | P51190 | NONE     |
| 17       | Coverplate                      | NONE          | NONE       | NONE     | P09421 | NONE     |

## COUPLER SELECTION

| ITEM NO. | PUMP SHAFT SIZE | FRAME SIZE | MOTOR SHAFT SIZE | STD COUPLER | EXPLOSION PROOF |
|----------|-----------------|------------|------------------|-------------|-----------------|
| 5        | 1/2"            | B&G        | 1/2"             | 118473      | P77234          |
| 5        | 1/2"            | B&G        | 5/8"             | 118709      | 118635          |
| 5        | 1/2"            | 56         | 5/8"             | 118709      | 118635          |

## POWER PACK SELECTION

| ITEM NO. | HP    | 1 PH, 115/230V<br>1750 RPM | 1 PH, 230/460V<br>3450 RPM ▼ | 3 PH, 208-230/460V<br>1750 RPM | 3 PH, 208-230/460V<br>3450 RPM ▼ | RING MOUNTS |
|----------|-------|----------------------------|------------------------------|--------------------------------|----------------------------------|-------------|
| 6        | 1/4   | 169040+                    | NONE                         | 169042                         | NONE                             | 118228      |
| 6        | 1/3   | 169043                     | 169044                       | 169045                         | 169046                           | 118228      |
| 6        | 1/2   | 169047                     | 169048                       | 169049                         | 169050                           | 118228      |
| 6        | 3/4   | 169051                     | 169052                       | 169053                         | 169054                           | 118228      |
| 6        | 1     | NONE                       | 169055                       | NONE                           | 169056                           | NONE        |
| 6        | 1-1/2 | NONE                       | 169057                       | NONE                           | 169058                           | NONE        |
| 6        | 2     | NONE                       | N/A                          | NONE                           | 169060                           | NONE        |

\*Steel Impeller

\*\*Doesn't include body gasket, impeller nut or impeller washer.

+115V. For 230V, use 169041

▼ For replacement purposes only. 1522 pumps are no longer available with this option.

N/A – No Longer Available.

— Factory recommended spare parts.

Note: Refer to pages 6 & 7 for exploded views of pump and bearing assembly.

## SEAL SELECTION CHART

| SEAL KIT* NO.       | SEAL ONLY NO. (LESS SEAT INSERT) | FOR PUMP MODEL(S)   | ELASTOMER MATERIAL | SEAL BODY CONSTRUCTION | SEAT INSERT MATERIAL |
|---------------------|----------------------------------|---|--------------------|------------------------|----------------------|
| 118681<br>(KIT #7)  | 118680                           | Series 100, HV, 2", PR, LD-3, HD-3, PD-35, PD-37, Series 60 "AA", 1522, Obs. 1", Obs. 1 1/4", Obs. 1 1/2", Obs. HV, Obs. 2", MF 60 with 5 1/4" and 6 1/4" impellers | Buna-N             | Brass                  | Ceramic              |
| 185222<br>(KIT #13) | –                                | Series 100, HV, 2", PR, LD-3, HD-3, PD-35, PD-37, Series 60 "AA", 1522, Obs. 1", Obs. 1 1/4", Obs. 1 1/2", Obs. HV, Obs. 2"   | EPT                | Steel                  | Tungsten Carbide     |
| 185223<br>(KIT #14) | –                                | PD-38, PD-40, Series 60 "A", Series 60 2 1/2F, Obs. PD-39, MF 60 with 7" impellers  | EPT                | Steel                  | Tungsten Carbide     |
| 185224<br>(KIT #15) | –                                | PD-38, PD-40, Series 60 "A", Series 60 2 1/2F, Obs. PD-39   | EPT                | Steel                  | Tungsten Carbide     |
| 185227<br>(KIT #18) | –                                | PD-38, PD-40, Series 60 "A", Series 60 2 1/2F, Obs. PD-39   | Teflon             | Stainless Steel        | Ceramic              |
| 185230<br>(KIT #12) | 118682                           | Series 100, HV, 2", PR, LD-3, HD-3, PD-35, PD-37, Series 60 "AA", 1522, Obs. 1", Obs. 1 1/4", Obs. 1 1/2", Obs. HV, Obs. 2", MF 60 with 5 1/4" and 6 1/4" impellers | EPT                | Brass                  | Tungsten Carbide     |
| 186433<br>(KIT #5)  | –                                | PD-38, PD-40, Series 60 "A", Series 60 2 1/2F, Obs. PD-39   | Buna-N             | Steel                  | Ceramic              |
| 186499<br>(KIT #2)  | –                                | PD-38, PD-40, Series 60 "A", Series 60 2 1/2F, Obs. PD-39, MF 60 with 7" impellers  | Buna-N             | Brass                  | Ceramic              |
| 186681<br>(KIT #6)  | –                                | Series 100, HV, 2", PR, LD-3, HD-3, PD-35, PD-37, Series 60 "AA", 1522, Obs. 1", Obs. 1 1/4", Obs. 1 1/2", Obs. HV, Obs. 2"   | Buna-N             | Steel                  | Ceramic              |
| 186875              | P59861                           | Series 100, HV, 2", PR, LD-3, HD-3, PD-35, PD-37, Series 60 "AA", 1522, Obs. 1", Obs. 1 1/4", Obs. 1 1/2", Obs. HV, Obs. 2", MF 60 with 5 1/4" and 6 1/4" impellers | Viton              | Stainless Steel        | Ceramic              |
| 189144              | –                                | PL-30, PL-30B, PL-36, PL-36B, PL-45, PL-45B, PL-50, PL-50B, PL-75, PL-75B   | EPT                | Brass                  | SiC                  |
| 189174              | –                                | PL-130/2, PL130B/2, PL-130/3, PL-130B/3   | EPT                | Brass                  | SiC                  |
| 189577              | –                                | PL-55, PL-55B   | EPT                | Brass                  | SiC                  |

Obs. – Obsolete pump models.

EPT – Ethyl Propylene Terpolymer (not oil resistant).

■ – Factory recommended spare parts.

# How to Select Parts for Hydronic Specialties or Engineered Specialties

The nameplate on any unit in the Hydronic Specialties or Engineered Hydronic Product line identifies the specific unit by product type, model number and six digit part number as shown in the example right.

The nameplate below right identifies the product as a reducing valve, model number B-38 with a part-number of 110190. The valve was manufactured in October, 1990. If the date code is not imprinted in the nameplate, a label displaying the date of manufacture identical to the example, above right, can be found on the product. Although all nameplates in the Hydronic Specialties and Engineered Hydronic Product lines are not alike, all will display the product type, part number and model number. **DO NOT REMOVE THE NAMEPLATE OR THE LABEL.** They identify the unit for future reference. It is important when ordering replacement parts to furnish complete nameplate data.

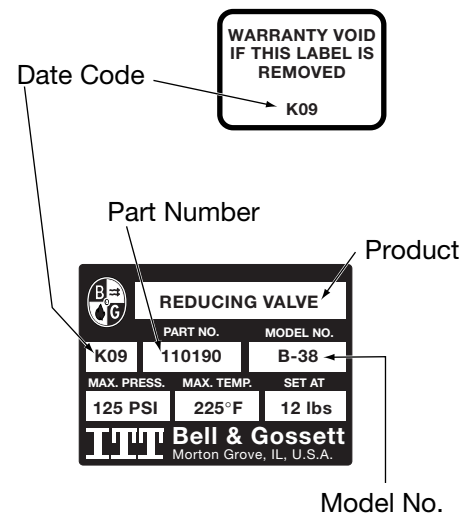

To insure the correct parts will be selected, follow the procedure below:

1. Determine from the nameplate the product type, model number and six digit part number.
2. Determine the date the unit was manufactured. See chart below.
3. Refer to the index for the page number of the parts breakdown for the specific product type.
4. Find the proper column in the parts breakdown for the model number involved.
5. Select part numbers using the exploded views for parts identification.

| DATE OF MANUFACTURE CODE  |           |   |  |   |           |   |      |   |           |    |      |
|---|-----------|---|--|---|-----------|---|------|---|-----------|----|------|
| The date code is made up of two or three characters depending upon the year.                    |           |   |  |   |           |   |      |   |           |    |      |
| 1946-1960<br>The number denotes the month. The last character is a letter and denotes the year. |           |   | 1961-82<br>Two characters. First letter is month. Second letter is year. |   |           | 1983-<br>Three characters. The letter denotes the month. The numbers denote the year. |      |   |           |    |      |
| 1   | January   | G | 1946   | A | January   | A   | 1961 | A | January   | 78 | 1987 |
| 2   | February  | H | 1947   | B | February  | B   | 1962 | B | February  | 88 | 1988 |
| 3   | March     | J | 1948   | C | March     | C   | 1963 | C | March     | 98 | 1989 |
| 4   | April     | K | 1949   | D | April     | D   | 1964 | D | April     | 09 | 1990 |
| 5   | May       | L | 1950   | E | May       | E   | 1965 | E | May       | 19 | 1991 |
| 6   | June      | M | 1951   | F | June      | F   | 1966 | F | June      | 29 | 1992 |
| 7   | July      | N | 1952   | G | July      | G   | 1967 | G | July      | 39 | 1993 |
| 8   | August    | P | 1953   | H | August    | H   | 1968 | H | August    | 49 | 1994 |
| 9   | September | R | 1954   | J | September | J   | 1969 | J | September | 59 | 1995 |
| 10  | October   | T | 1955   | K | October   | K   | 1970 | K | October   | 69 | 1996 |
| 11  | November  | U | 1956   | L | November  | L   | 1971 | L | November  | 79 | 1997 |
| 12  | December  | V | 1957   | M | December  | M   | 1972 | M | December  | 89 | 1998 |
|   |           | W | 1958   |   |           | N   | 1973 |   |           | 99 | 1999 |
|   |           | X | 1959   |   |           | P   | 1974 |   |           | 00 | 2000 |
|   |           | Y | 1960   |   |           | R   | 1975 |   |           | 10 | 2001 |
|   |           |   |  |   |           | T   | 1976 |   |           | 20 | 2002 |
|   |           |   |  |   |           | U   | 1977 |   |           | 30 | 2003 |
|   |           |   |  |   |           | V   | 1978 |   |           | 40 | 2004 |
|   |           |   |  |   |           | W   | 1979 |   |           | 50 | 2005 |
|   |           |   |  |   |           | X   | 1980 |   |           | 60 | 2006 |
|   |           |   |  |   |           | Y   | 1981 |   |           | 70 | 2007 |
|   |           |   |  |   |           | Z   | 1982 |   |           | 80 | 2008 |
|   |           |   |  |   |           |   |      |   |           | 90 | 2009 |

# PARTS FOR FLO-CONTROL VALVES

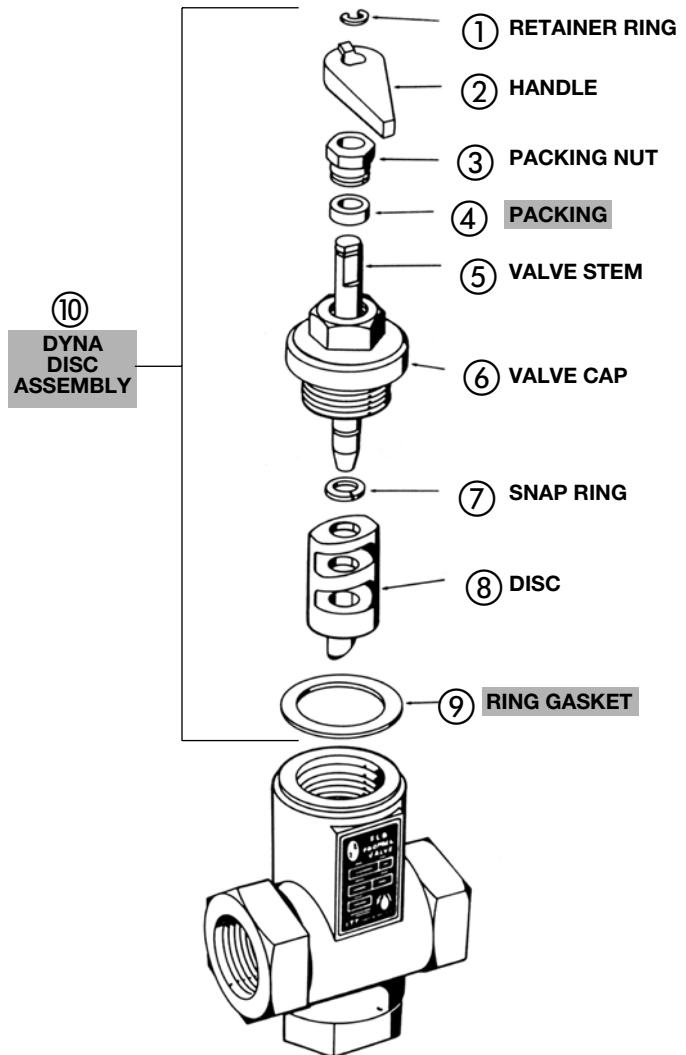
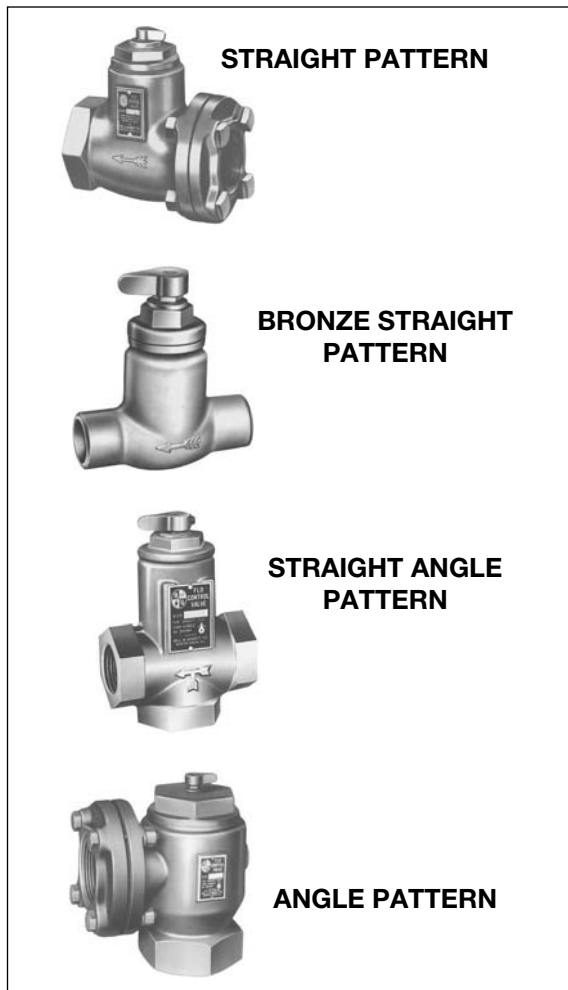

| ITEM NO. | DESCRIPTION        | SA-3/4<br>107034 | SA-1<br>107018 | SA-1 1/4<br>107019 | SA-1 1/2<br>107020 | SB-3/4<br>107024 | SA-2<br>107021 | A-2 1/2<br>107006<br>S-2 1/2<br>107014 | A-3<br>107007<br>S-3<br>107015 | S-4<br>107004 |
|----------|--------------------|------------------|----------------|--------------------|--------------------|------------------|----------------|--|--------------------------------|---------------|
| 10       | Dyna Disc Assembly | 189168           | 118117         | 118094             | 118095             | 118864           | 118095         | 118096                                 | 118096                         | 118118        |
| 1        | Retainer Ring      | J92350           | F02800         | F20800             | F20800             | J92350           | F20800         | F22200                                 | F22200                         | F06800        |
| 3        | Packing Nut        | 118056           | 118056         | 118056             | 118056             | 118056           | 118056         | 118056                                 | 118056                         | F16600        |
| 4        | Packing            | 118057           | 118057         | 118057             | 118057             | 118057           | 118057         | 118057                                 | 118057                         | F17000        |
| 7        | Snap Ring          | F42800           | F42800         | F42800             | F42800             | F42800           | F42800         | F42800                                 | F42800                         | NONE          |
| 9        | Ring Gasket        | F43000           | F44400         | F47200             | F49000             | V56936           | F49000         | F27800                                 | F27800                         | F19000        |
|          | Flange Gasket      | NONE             | NONE           | NONE               | NONE               | NONE             | F26200         | G82750                                 | G86500                         | F17400        |

■ - Factory recommended spare parts.

**NOTE:** Consult factory if parts other than those listed above are required.

# PARTS FOR PRESSURE REDUCING VALVES & DUAL UNIT VALVES (a)

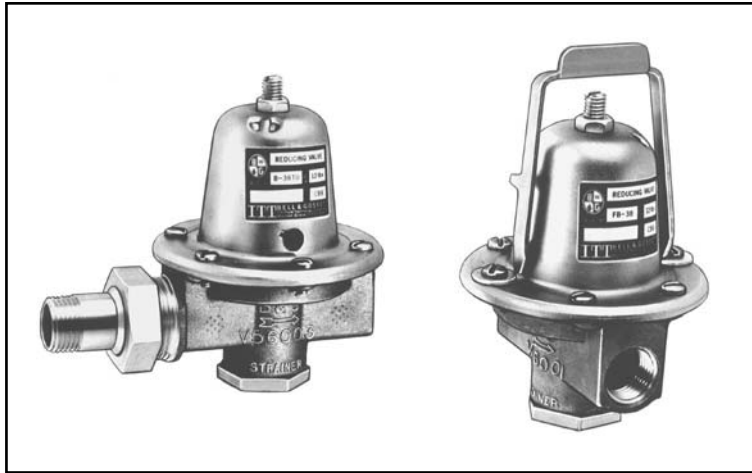

**ASSEMBLED REDUCING VALVES**

| ITEM NO. | DESCRIPTION                                       | PART NUMBER |
|----------|---|-------------|
|          | Repair Kit*                                       | 118861      |
| 5        | Diaphragm   | 118029      |
| 14       | Rubber Check Valve (Round**)                      | V51658      |
| 11       | Strainer (B-38, B-38TU, FB-38, FB-38TU, #6***)    | 118036      |
| 11       | Strainer (#7***, B7-12)                           | 189160      |
| 10       | Strainer Nut & O-ring                             | V14609      |
|          | Tail Piece Assembly (B-38TU, FB-38TU, 8TU, F-8TU) | V51747      |
|          | Tail Piece Gasket                                 | V51657      |

■ - Factory recommended spare parts.

(a) Parts are not available for the relief valve of each Dual Unit Valve model.

\*Repair Kit includes diaphragm, rubber check valve, valve plate, stem assembly, strainers, hex nuts and loctite.

\*\*Old style check valve is hexagon-shaped.

\*\*\*Manufactured May, 1988 (E88 date code) and after.

**NOTE:** Consult factory if replacement parts other than those listed above are required.

Consult factory if replacement parts are required for old style reducing valves and dual unit valves with the following model no's: #6 and #7 (date code D88 and before), #12, D525, B3, B8, FB3, FB8, F3, F8, #3, #8 and B7.

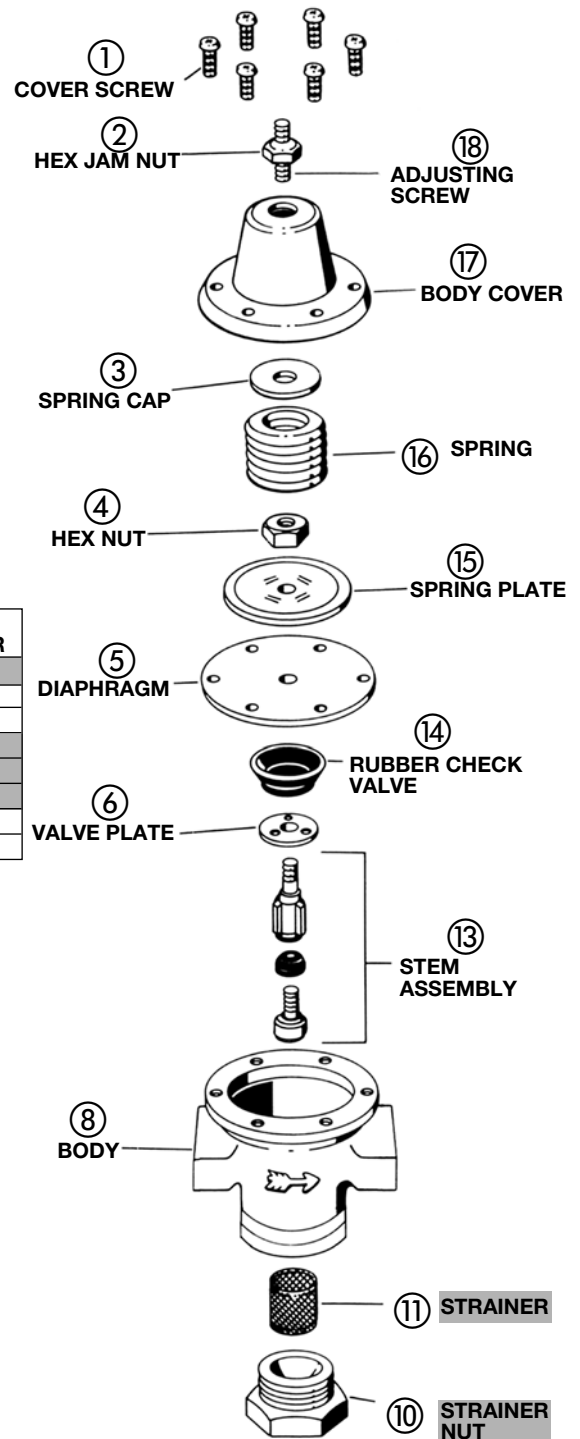

# PARTS FOR COMFORT-TROL/ OBSOLETE MODUMATE ZONE VALVES

## ASSEMBLED MODUMATE VALVE (M-1) OBSOLETE

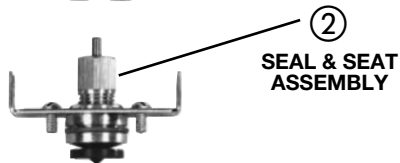
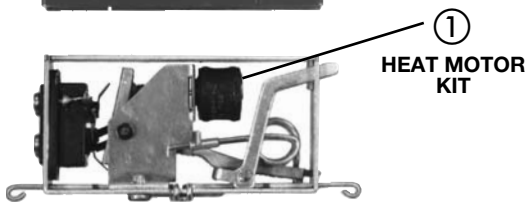

## ASSEMBLED COMFORT-TROL VALVE

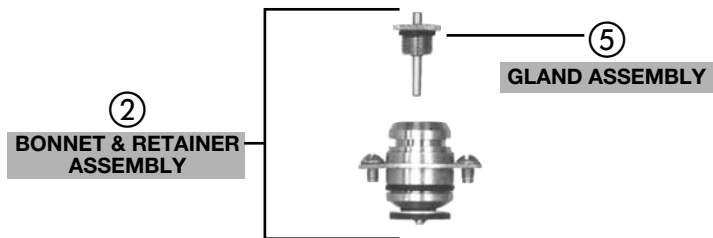
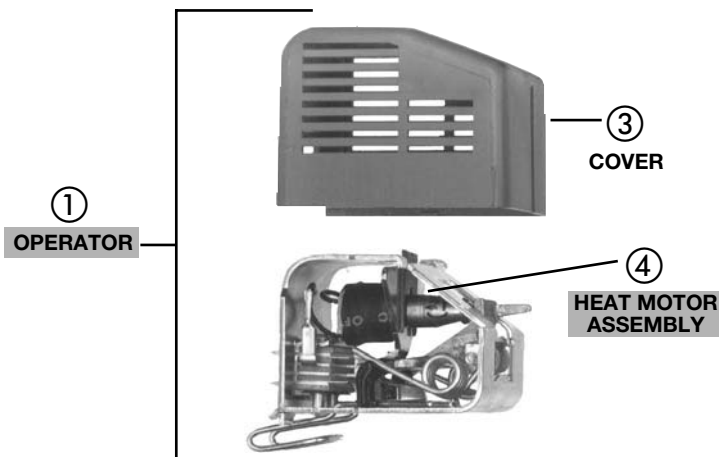

| ITEM NO. | DESCRIPTION          | PART NO. |
|----------|----------------------|----------|
| 1        | Heat Motor Kit       | 189143   |
| 2        | Seal & Seat Assembly | 189060   |

| ITEM NO. | DESCRIPTION                         | PART NO. |
|----------|-------------------------------------|----------|
| 1        | Operator                            | 109024   |
| 2        | Bonnet & Retainer Assembly (6 Pack) | 189139   |
| 3        | Cover                               | V01340   |
| 4        | Heat Motor Assembly (6 Pack)        | 189137   |
| 5        | Gland Assembly (6 Pack)             | 189138   |
| 6        | Body (CTS-7524)                     | V01103   |

■ - Factory recommended spare parts.

# ENHANCED AIR SEPARATORS

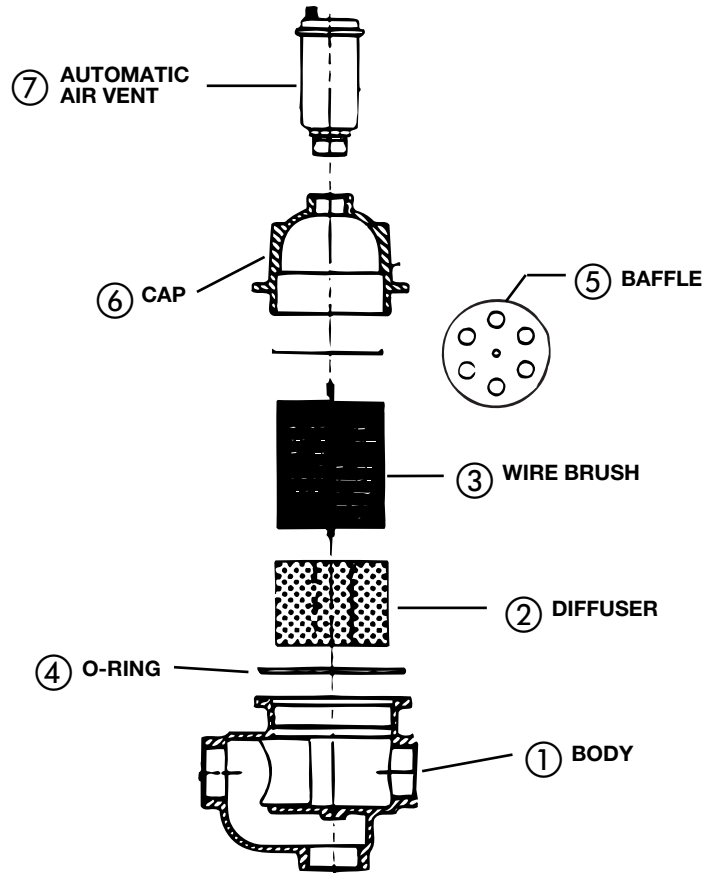

| ITEM NO. | DESCRIPTION | MODEL  |                                   |                                   |        |
|----------|-------------|--------|-----------------------------------|-----------------------------------|--------|
|          |             | EAS-1  | EAS-1 <sup>1</sup> / <sub>4</sub> | EAS-1 <sup>1</sup> / <sub>2</sub> | EAS-2  |
| 1        | Body        | A03831 | A03832                            | A03715                            | A03716 |
| 2        | Diffuser    | A03837 | A03837                            | A03717                            | A03717 |
| 3        | Wire Brush  | A03836 | A03836                            | A03718                            | A03718 |
| 4        | O-Ring      | A03841 | A03841                            | A03719                            | A03719 |
| 5        | Baffle      | A03835 | A03835                            | A03720                            | A03720 |
| 6        | Cap         | A03834 | A03834                            | A03722                            | A03722 |
| 7        | Air Vent    | A03842 | A03842                            | A03842                            | A03723 |



# PARTS FOR MODEL 107A HIGH CAPACITY AIR VENT

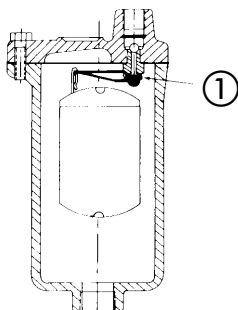

| ITEM NO. | DESCRIPTION            | PART NO. |
|----------|------------------------|----------|
| 1        | Lever, Button & Gasket | 118855   |

**MODEL 107A VENT**

## REPLACEMENT BLADDER PARTS FOR THE B & B-LA SERIES TANKS

### SERIES "B" REPLACEMENT BLADDERS

| TANK PART NUMBER | TANK MODEL NUMBER | BLADDER PART NUMBER |
|------------------|-------------------|---------------------|
| 116550           | B-200             | 189579              |
| 116551           | B-300             | 189580              |
| 116552           | B-400             | 189581              |
| 116553           | B-500             | 189582              |
| 116554           | B-600             | 189583              |
| 116555           | B-800             | 189584              |
| 116556           | B-1000            | 189585              |
| 116557           | B-1200            | 189586              |
| 116558           | B-1400            | 189587              |
| 116559           | B-1600            | 189588              |
| 116560           | B-2000            | 189589              |
| 116793           | B-2500            | 189590              |
| 116794           | B-3000            | 189591              |
| 116795           | B-3500            | 189592              |
| 116796           | B-4000            | 189593              |
| 116819           | B-5000            | 189597              |

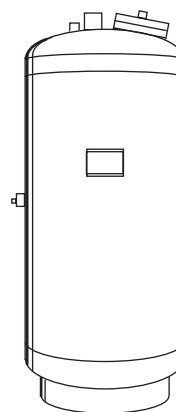

### SERIES "B-LA" REPLACEMENT BLADDERS

| TANK PART NUMBER | TANK MODEL NUMBER | BLADDER PART NUMBER |
|------------------|-------------------|---------------------|
| 116782           | B-35 LA           | 189594              |
| 116783           | B-50 LA           |                     |
| 116784           | B-85 LA           |                     |
| 116785           | B-100 LA          | 189595              |
| 116786           | B-130 LA          |                     |
| 116787           | B-165 LA          |                     |
| 116788           | B-200 LA          |                     |
| 116789           | B-300 LA          | 189596              |
| 116790           | B-400 LA          |                     |
| 116791           | B-500 LA          |                     |
| 116792           | B-600 LA          |                     |

# PARTS FOR THERMOFLO BALANCERS



**ASSEMBLED THERMOFLO BALANCER**

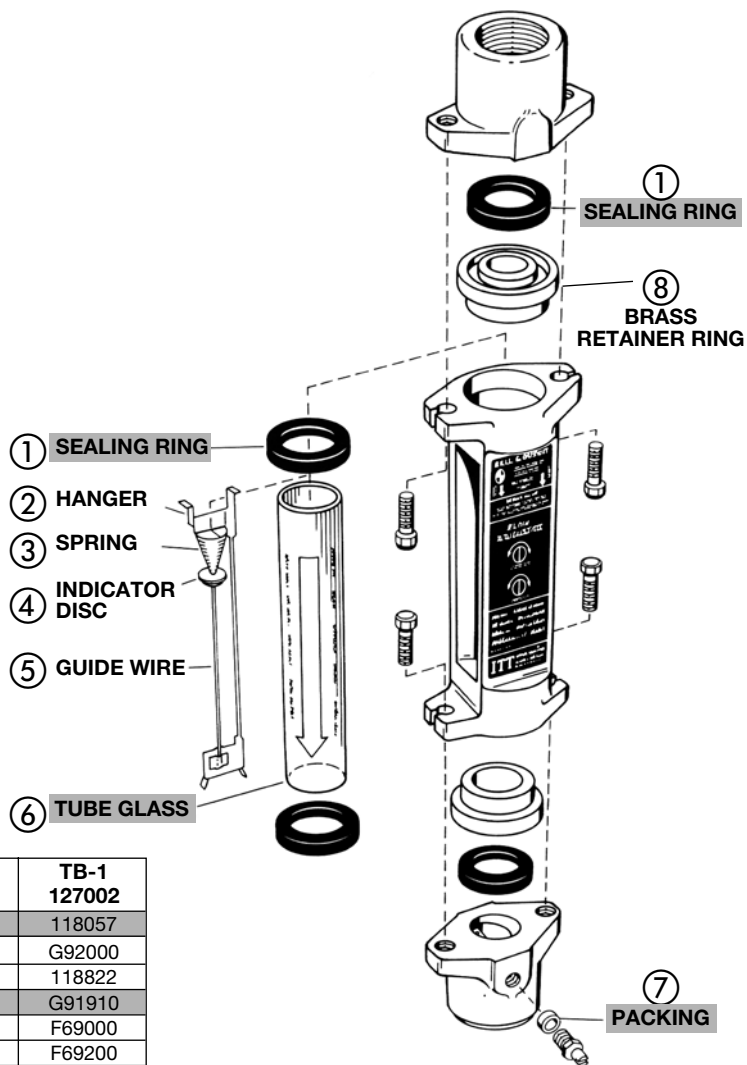

| ITEM NO. | DESCRIPTION                        | TB-3/4<br>127001 | TB-1<br>127002 |
|----------|------------------------------------|------------------|----------------|
| 7        | Packing                            | 118057           | 118057         |
| 8        | Retainer Ring - Brass (2 required) | G92000           | G92000         |
|          | Glass Tube Kit Consisting of:      | 118098           | 118822         |
| 6        | Tube Glass                         | G91908           | G91910         |
| 2        | Hanger                             | F69000           | F69000         |
| 5        | Guide Wire                         | F69200           | F69200         |
| 4        | Indicator Disc                     | F62800           | NONE           |
| 3        | Spring                             | F66800           | F66200         |
| 1        | Sealing Ring (4 required)          | F67200           | F67200         |

■ - Factory recommended spare parts.

# PARTS FOR THERMOFLO INDICATORS

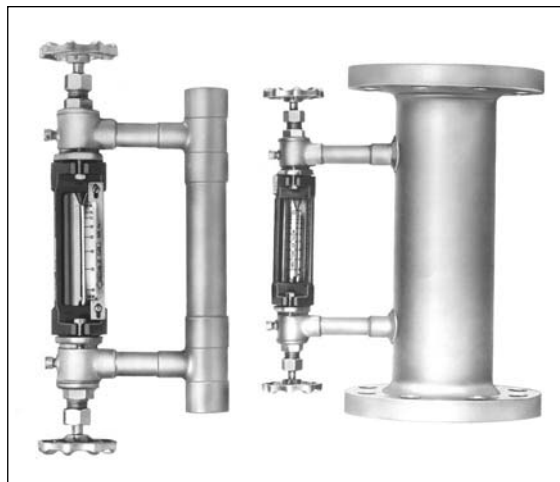

**ASSEMBLED THERMOFLO INDICATOR**

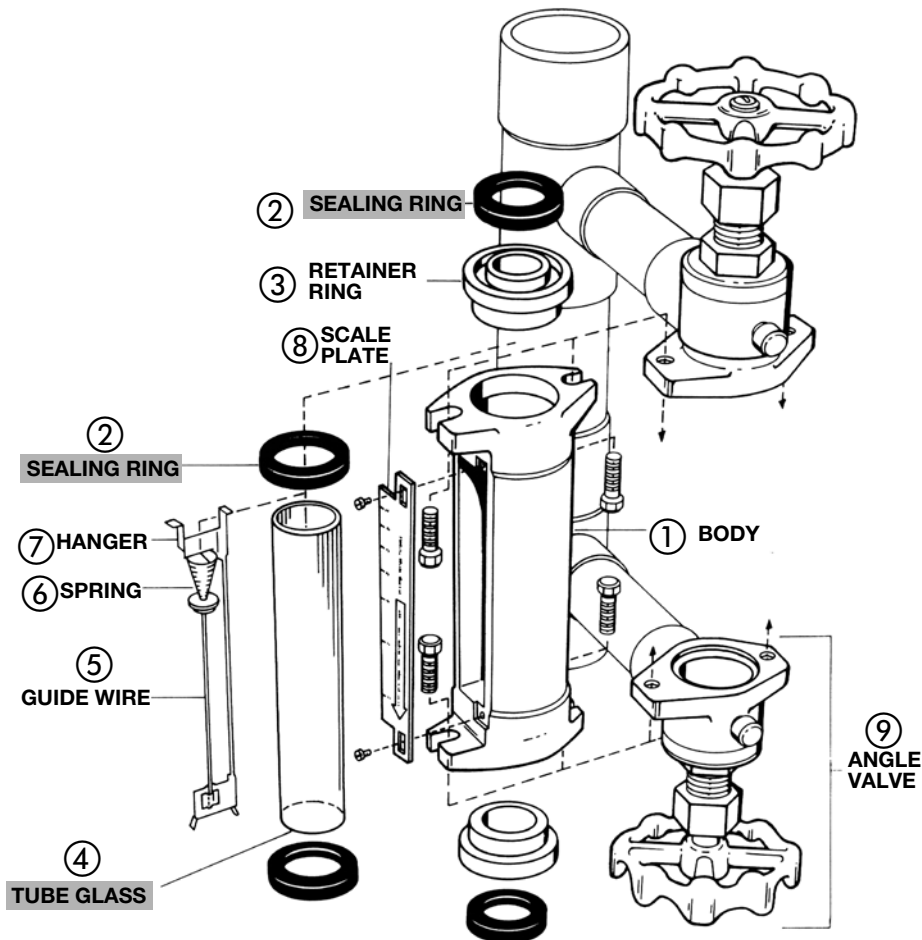

| ITEM NO. | DESCRIPTION                       | TFI-1 <sup>1</sup> / <sub>4</sub><br>140001 | TFI-1 <sup>1</sup> / <sub>2</sub><br>140002 | TFI-2<br>140003 | TFI-2 <sup>1</sup> / <sub>2</sub><br>140004 | TFI-3<br>140005 | TFI-4<br>140006 | TFI-5<br>140007 | TFI-6<br>140008 | TFI-8<br>140009 |
|----------|-----------------------------------|---|---|-----------------|---|-----------------|-----------------|-----------------|-----------------|-----------------|
| 1        | Body                              | G92500                                      | →   | →               | →   | →               | →               | →               | →               | →               |
| 3        | Retainer Ring (2 req'd)           | G92000                                      | →   | →               | →   | →               | →               | →               | →               | →               |
| 9        | Angle Valve (2 req'd)             | G95000                                      | →   | →               | →   | →               | →               | →               | →               | →               |
|          | Glass Tube Kit New Style (Clear)  | 189111                                      | →   | →               | →   | →               | NONE            | NONE            | NONE            | NONE            |
|          | Glass Tube Kit Old Style (Etched) | 118820                                      | →   | →               | →   | →               | →               | →               | →               | →               |
| 8        | Scale Plate                       | G95594                                      | G95595                                      | G95596          | G95597                                      | G95598          | G95915          | G95916          | G95917          | G95918          |

## GLASS TUBE KITS

| ITEM NO. | DESCRIPTION               | CLEAR<br>189111 | ETCHED<br>118820 |
|----------|---------------------------|-----------------|------------------|
| 4        | Tube Glass                | G91900          | G91904           |
| 7        | Hanger                    | F69000          | →                |
| 5        | Guide Wire                | F69200          | →                |
| 6        | Spring                    | F66800          | →                |
| 2        | Sealing Ring (4 required) | F67200          | →                |

■ - Factory recommended spare parts.

# CIRCUIT SETTER BALANCE VALVES

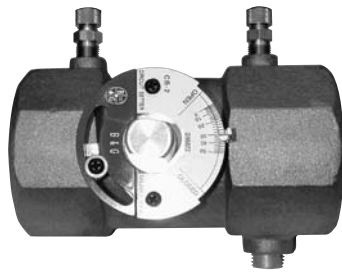

**BALL STYLE VALVES**



**VANE STYLE VALVE\***

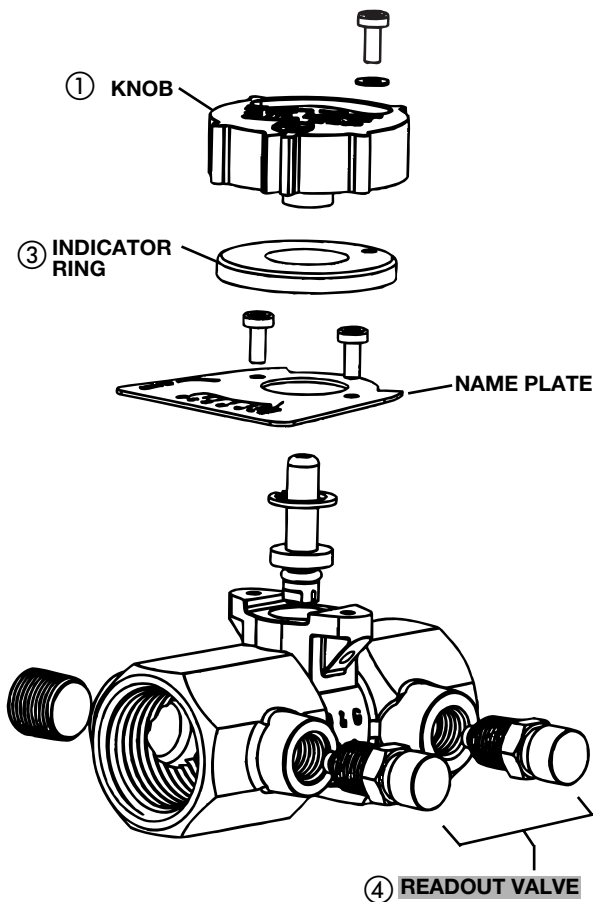

**SMALL DESIGN BALL STYLE VALVE**  
1/2" - 1"

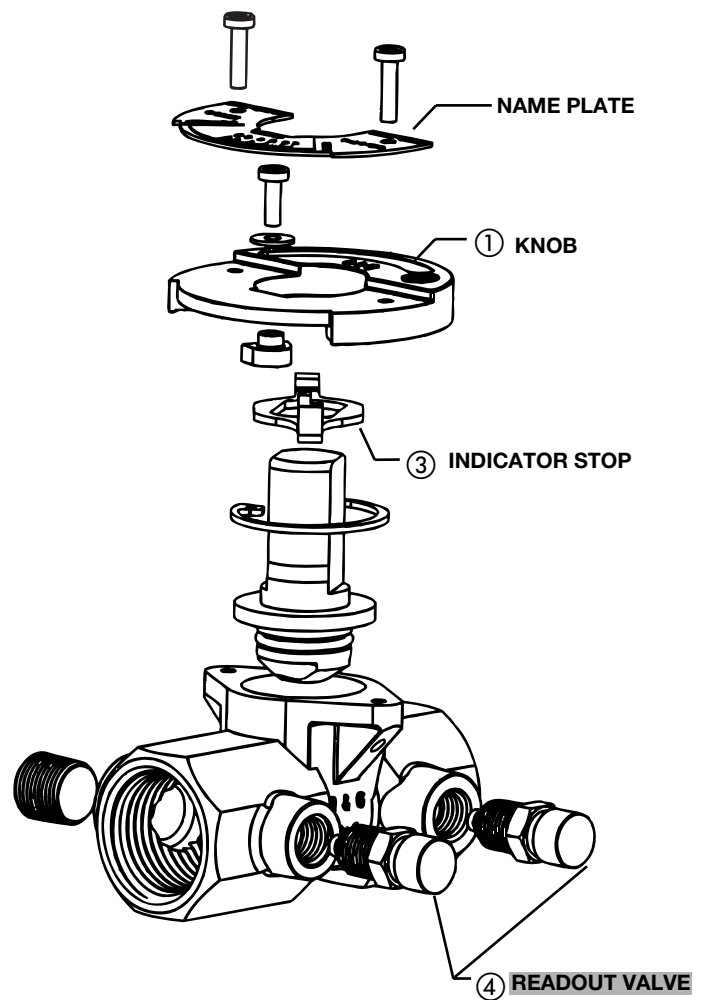

**LARGE DESIGN BALL STYLE VALVE**  
1 1/4" - 3"

\*Exploded view for obsolete Vane Style Valve is not shown. Replacement parts are not available.

■ - Factory recommended spare parts.

# PARTS FOR CIRCUIT SETTERS (CONTINUED)

## CIRCUIT SETTER "RF" & CIRCUIT SETTER PLUS

### BALL STYLE VALVES (see page 44 for exploded view of current style valves)

|           |          | Valves Manuf.<br>before July 2000<br>(G00 Date Code) | Valves Manuf.<br>July 2000 & After<br>(G00 Date Code) | Valves Manuf.<br>July 2000 & After<br>(G00 Date Code) | Valves Manuf.<br>before Jan. 2004<br>(A40 Date Code) | Valves Manuf.<br>Jan. 2004 & After<br>(A40 Date Code) | All Valves        |
|-----------|----------|--|---|---|--|---|-------------------|
| MODEL NO. | PART NO. | KNOB   |   | INDICATOR STOP  | READOUT VALVE  |   | READOUT PROBE     |
| RF-1/2S   | 117410   | G10105   | G10105  | -   | G97030 (1 Pair)*<br>(1/8" NPT)                       | V58050 (Each)<br>(1/4" NPT)                           | G97032 (1 Pair)** |
| RF-3/4S   | 117411   | G10105   | G10105  | -   |  |   |                   |
| CB-1/2    | 117414   | G95951   | G95951  | -   |  |   |                   |
| CB-1/2S   | 117412   | G95951   | G95951  | -   |  |   |                   |
| CB-3/4    | 117415   | G95951   | G95951  | -   |  |   |                   |
| CB-3/4S   | 117413   | G95951   | G95951  | -   |  |   |                   |
| CB-1      | 117416   | G95951   | G95951  | -   |  |   |                   |
| CB-1S     | 117401   | G95951   | G95951  | -   |  |   |                   |
| CB-11/4   | 117103   | -  | G96831  | G96839  |  |   |                   |
| CB-11/4S  | 117402   | -  | G96831  | G96839  |  |   |                   |
| CB-11/2   | 117104   | -  | G96831  | G96839  |  |   |                   |
| CB-11/2S  | 117403   | -  | G96831  | G96839  |  |   |                   |
| CB-2      | 117105   | -  | G96831  | G96839  |  |   |                   |
| CB-2S     | 117404   | -  | G96831  | G96839  |  |   |                   |
| CB-21/2   | 117106   | -  | G96831  | G96839  |  |   |                   |
| CB-21/2F  | 117116   | -  | G96831  | G96839  |  |   |                   |
| CB-3      | 117107   | -  | G96831  | G96839  |  |   |                   |
| CB-3F     | 117117   | -  | G96831  | G96839  |  |   |                   |
| CB-4†     | 117035   | -  | G96831  | G96839  |  |   |                   |

\*Also use Readout Valve model RV-125A, P/N 113100 (50 pairs per package).

\*\*Also use Readout Probe model RP-250B, P/N 113102 (6 pairs per package).

† - CB-4 manufactured after March 2001.

■ - Factory recommended spare parts.

# PARTS FOR CIRCUIT SETTERS (CONTINUED)



**GLOBE STYLE VALVE**

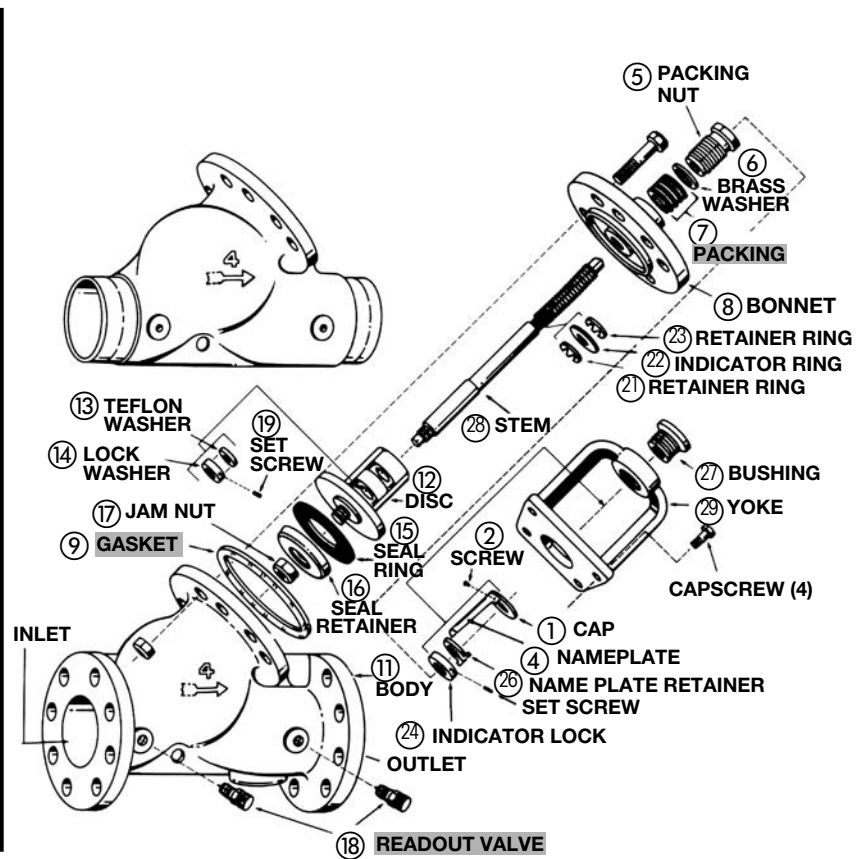

## GLOBE STYLE VALVES

| ITEM NO. | DESCRIPTION               | CB-4F 117112 | CB-4G 117118 | CB-5F 117113 | CB-5G 117119 | CB-6F 117114 | CB-6G 117120 | CB-8F 117115 | CB-8G 117121 | CB-10F 117420 | CB-10G 117422 | CB-12F 117421 | CB-12G 117423 |
|----------|---------------------------|--------------|--------------|--------------|--------------|--------------|--------------|--------------|--------------|---------------|---------------|---------------|---------------|
| 11       | Body Assembly*            | V50833       | V18802       | V50834       | V50821       | V50835       | V50822       | V50836       | V50823       | V50837        | V50824        | V50838        | V50825        |
| 9        | Gasket                    | V29400       | V29400       | V32801       | V32801       | V33001       | V33001       | V35000       | V35000       | V36400        | V36400        | V36401        | V36401        |
| 8        | Bonnet                    | G10001       | G10060       | G10002       | G10061       | G10003       | G10062       | G10004       | G10063       | V51021        | V50986        | V50987        | V50988        |
| 28       | Stem                      | G10005       | G10005       | G10006       | G10006       | G10007       | G10007       | G10008       | G10008       | V50989        | V50989        | V50990        | V50990        |
| 12       | Disc**                    | G10009       | G10009       | G10010       | G10010       | G10011       | G10011       | G10012       | G10012       | V50992        | V50992        | V50993        | V50993        |
| 15       | Seal Ring**               | V50935       | V50935       | V50936       | V50936       | V50937       | V50937       | V50938       | V50938       | V50939        | V50939        | V50940        | V50940        |
| 16       | Seal Retainer             | G10013       | G10013       | G10014       | G10014       | G10015       | G10015       | G10016       | G10016       | V50994        | V50994        | V50995        | V50995        |
| 17       | Jam Nut**                 | J91635       | J91635       | J91635       | J91635       | J91635       | J91635       | J91636       | J91636       | J91636        | J91636        | J91636        | J91636        |
| 5        | Packing Nut               | G10026       | G10026       | G10026       | G10026       | G10026       | G10026       | G10034       | G10034       | G10034        | G10034        | V51002        | V51002        |
| 6        | Gland Washer              | G10032       | G10032       | G10032       | G10032       | G10032       | G10032       | G10040       | G10040       | G10040        | G10040        | V51003        | V51003        |
| 7        | Packing (4 req'd)         | G10033       | G10033       | G10033       | G10033       | G10033       | G10033       | G10041       | G10041       | G10041        | G10041        | V51004        | V51004        |
| 18       | Readout Valve (1 set)     | G97030       | G97030       | G97030       | G97030       | G97030       | G97030       | G97030       | G97030       | G97030        | G97030        | G97030        | G97030        |
| 4        | Nameplate                 | G10017       | G10064       | G10018       | G10065       | G10019       | G10066       | G10020       | G10067       | V50996        | V50998        | V50997        | V50999        |
| 2        | Nameplate Screw (2 req'd) | J92135       | J92135       | J92135       | J92135       | J92135       | J92135       | J92135       | J92135       | J92135        | J92135        | J92135        | J92135        |
| 1        | Nameplate Cap             | G10025       | G10025       | G10025       | G10025       | G10025       | G10025       | G10025       | G10025       | G10025        | G10025        | V51005        | V51005        |
| 21       | Retainer Ring             | J92345       | J92345       | J92345       | J92345       | J92345       | J92345       | J92347       | J92347       | J92347        | J92347        | V51008        | V51008        |
| 23       | Retainer Ring             | J92346       | J92346       | J92346       | J92346       | J92346       | J92346       | J92348       | J92348       | J92348        | J92348        | -             | -             |
| 26       | Retainer Ring             | J92349       | J92349       | J92349       | J92349       | J92349       | J92349       | J92349       | J92349       | J92349        | J92349        | -             | -             |
| 22       | Retainer Ring             | G10029       | G10029       | G10029       | G10029       | G10029       | G10029       | G10037       | G10037       | G10037        | G10037        | -             | -             |
| 27       | Bushing                   | G10030       | G10030       | G10030       | G10030       | G10030       | G10030       | G10038       | G10038       | V51010        | V51010        | V51011        | V51011        |
| 24       | Indicator Lock            | G10028       | G10028       | G10028       | G10028       | G10028       | G10028       | G10036       | G10036       | G10036        | G10036        | V51012        | V51012        |
| 14       | Lockwasher**              | G10027       | G10027       | G10027       | G10027       | G10027       | G10027       | G10035       | G10035       | G10035        | G10035        | G10035        | G10035        |
| 13       | Teflon Washer**           | G10031       | G10031       | G10031       | G10031       | G10031       | G10031       | G10039       | G10039       | G10039        | G10039        | G10039        | G10039        |
| 19       | Set Screw**               | J92020       | J92020       | J92020       | J92020       | J92020       | J92020       | J92020       | J92020       | J92020        | J92020        | J92020        | J91999        |
| 29       | Yoke                      | G10022       | G10022       | G10022       | G10022       | G10024       | G10024       | G10024       | G10024       | V51000        | V51000        | V51000        | V51000        |

\*Body assembly includes seat ring.

\*\*When replacing the disc, all six disc parts are necessary.

■ - Factory recommended spare parts.

# How to Select Parts for Centrifugal Pump Accessories

The nameplate on any unit in the Centrifugal Pump Accessories line identifies the specific unit by product type, model number and six digit part number as shown in the example below right.

The nameplate identifies the product as a suction diffuser, model number JH-3 with a part number of 115035. The suction diffuser was manufactured in August, 1991. If the date code is not imprinted on the nameplate, a label displaying the date of manufacture identical to the example above the right can be found on the product. Although all nameplates in the Centrifugal Pump Accessories line do not look alike, all will display the product type, part number and model number. **DO NOT REMOVE THE NAMEPLATE OR THE LABEL.** They identify the unit for future reference. It is important when ordering replacement parts to furnish complete nameplate data.

To insure the correct parts will be selected, follow the procedure below:

1. Determine from the nameplate the product type, model number and six digit part number.
2. Determine the date the unit was manufactured. See chart below.
3. Refer to the index for the page number of the parts breakdown for the specific product type.
4. Find the proper column in the parts breakdown for the model number involved.
5. Select part numbers using the exploded views for parts identification.

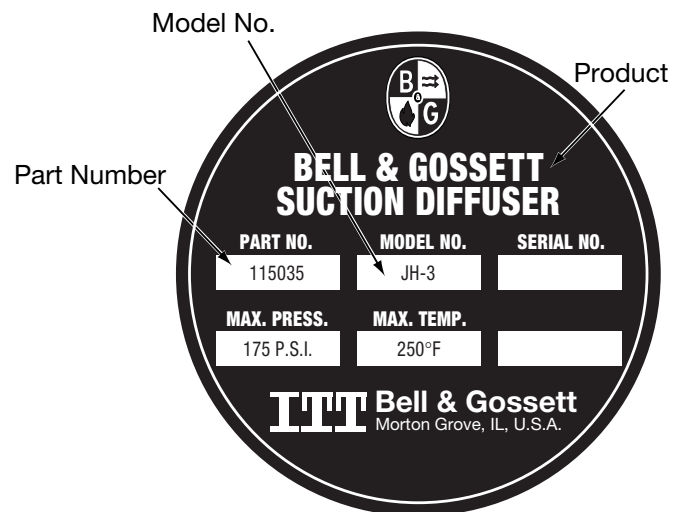
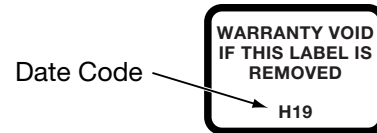

| DATE OF MANUFACTURE CODE  |           |   |  |   |           |   |      |   |           |    |      |
|---|-----------|---|--|---|-----------|---|------|---|-----------|----|------|
| The date code is made up of two or three characters depending upon the year.                    |           |   |  |   |           |   |      |   |           |    |      |
| 1946-1960<br>The number denotes the month. The last character is a letter and denotes the year. |           |   | 1961-82<br>Two characters. First letter is month. Second letter is year. |   |           | 1983-<br>Three characters. The letter denotes the month. The numbers denote the year. |      |   |           |    |      |
| 1   | January   | G | 1946   | A | January   | A   | 1961 | A | January   | 78 | 1987 |
| 2   | February  | H | 1947   | B | February  | B   | 1962 | B | February  | 88 | 1988 |
| 3   | March     | J | 1948   | C | March     | C   | 1963 | C | March     | 98 | 1989 |
| 4   | April     | K | 1949   | D | April     | D   | 1964 | D | April     | 09 | 1990 |
| 5   | May       | L | 1950   | E | May       | E   | 1965 | E | May       | 19 | 1991 |
| 6   | June      | M | 1951   | F | June      | F   | 1966 | F | June      | 29 | 1992 |
| 7   | July      | N | 1952   | G | July      | G   | 1967 | G | July      | 39 | 1993 |
| 8   | August    | P | 1953   | H | August    | H   | 1968 | H | August    | 49 | 1994 |
| 9   | September | R | 1954   | J | September | J   | 1969 | J | September | 59 | 1995 |
| 10  | October   | T | 1955   | K | October   | K   | 1970 | K | October   | 69 | 1996 |
| 11  | November  | U | 1956   | L | November  | L   | 1971 | L | November  | 79 | 1997 |
| 12  | December  | V | 1957   | M | December  | M   | 1972 | M | December  | 89 | 1998 |
|   |           | W | 1958   |   |           | N   | 1973 |   |           | 99 | 1999 |
|   |           | X | 1959   |   |           | P   | 1974 |   |           | 00 | 2000 |
|   |           | Y | 1960   |   |           | R   | 1975 |   |           | 10 | 2001 |
|   |           |   |  |   |           | T   | 1976 |   |           | 20 | 2002 |
|   |           |   |  |   |           | U   | 1977 |   |           | 30 | 2003 |
|   |           |   |  |   |           | V   | 1978 |   |           | 40 | 2004 |
|   |           |   |  |   |           | W   | 1979 |   |           | 50 | 2005 |
|   |           |   |  |   |           | X   | 1980 |   |           | 60 | 2006 |
|   |           |   |  |   |           | Y   | 1981 |   |           | 70 | 2007 |
|   |           |   |  |   |           | Z   | 1982 |   |           | 80 | 2008 |
|   |           |   |  |   |           |   |      |   |           | 90 | 2009 |

# PARTS FOR TRIPLE DUTY VALVES



**ASSEMBLED MODEL 3DX  
TRIPLE DUTY VALVE**

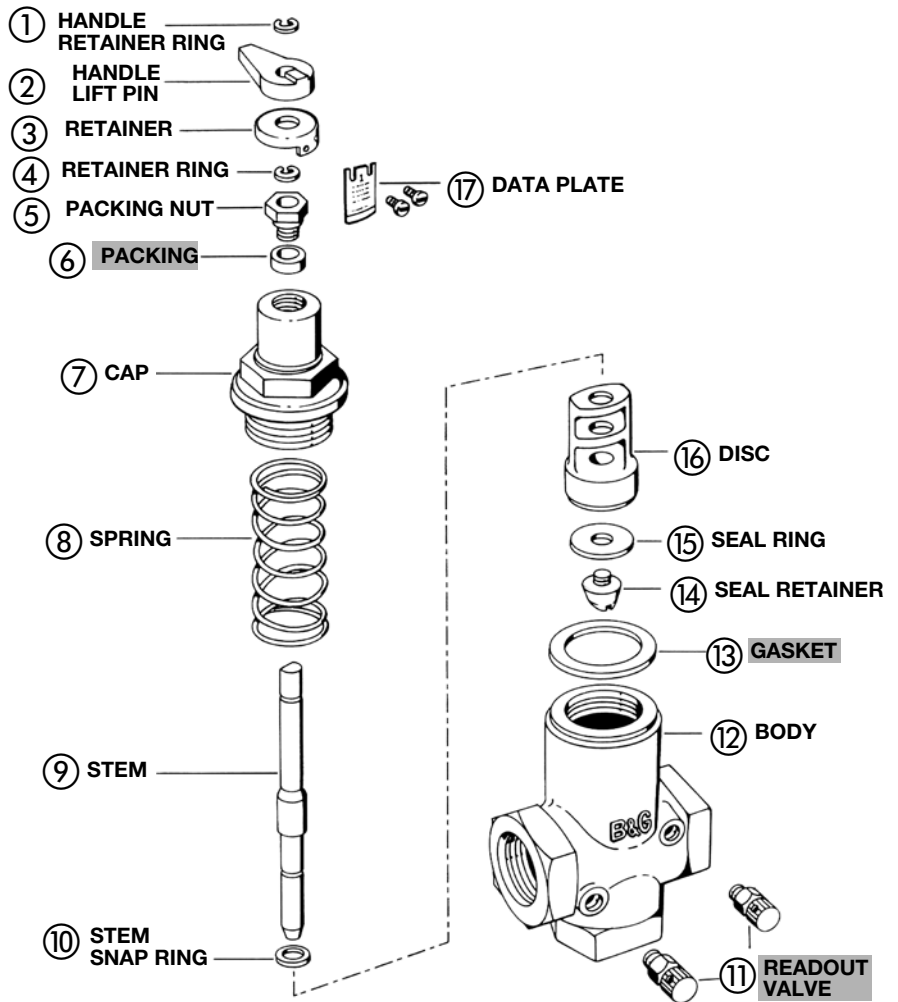

## MODEL 3DX

| ITEM NO. | DESCRIPTION             | 3DX-1<br>132072 | 3DX-1 <sup>1</sup> / <sub>4</sub><br>132159 | 3DX-1 <sup>1</sup> / <sub>2</sub><br>132074 |
|----------|-------------------------|-----------------|---|---|
| 12       | Body                    | V50807          | V50808                                      | V50809                                      |
| 11       | Readout Valve Set*      | G97030          | G97030                                      | G97030                                      |
|          | Readout Probe Set**     | G97032          | G97032                                      | G97032                                      |
|          | Disc Kit Consisting of: | 118860          | 118858***                                   | 118859                                      |
| 9        | Stem                    | V50767          | V50768                                      | V50769                                      |
| 16       | Disc                    | V50697          | V50698                                      | V50699                                      |
| 15       | Seal Ring               | V50781          | V50782                                      | V50783                                      |
| 14       | Seal Retainer           | V50686          | V56889                                      | V50688                                      |
| 8        | Spring                  | V51077          | V51078                                      | V51079                                      |
| 7        | Cap                     | V50690          | V50693                                      | V50696                                      |
| 13       | Ring Gasket             | F44400          | F47200                                      | F49000                                      |
| 6        | Packing                 | 118057          | 118057                                      | 118057                                      |
| 5        | Packing Nut             | 118056          | 118056                                      | 118056                                      |
| 17       | Data Plate              | V50855          | V50856                                      | V50857                                      |
| 2        | Handle Lift Pin         | F13400          | F13400                                      | F13400                                      |
| 1        | Handle Retainer Ring    | F42800          | F42800                                      | F42800                                      |
| 10       | Stem Snap Ring          | F02800          | F20800                                      | F20800                                      |
| 4        | Retainer Ring           | J92344          | J92344                                      | J92344                                      |
| 3        | Retainer                | V50740          | V50740                                      | V50740                                      |

\*Also use Readout Valve model RV-125A, P/N 113100 (50 pairs per package).

\*\*Also use Readout Probe model RP-250B, P/N 113102 (6 pairs per package).

\*\*\*Also includes V50687, seal retainer for old style 3DX-1<sup>1</sup>/<sub>4</sub>.

■ - Factory recommended spare parts.



# PARTS FOR TRIPLE DUTY VALVES (CONTINUED)

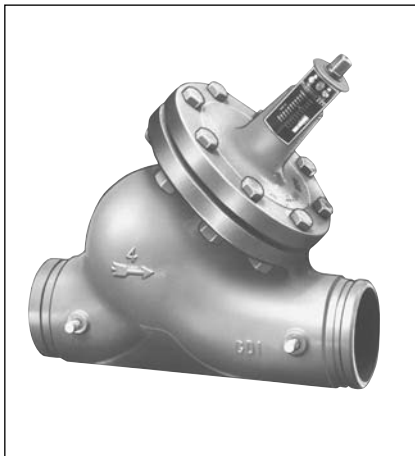

**ASSEMBLED TRIPLE DUTY VALVE**

**NOTE: DISC IS NOT AVAILABLE SEPARATELY ON 2" THROUGH 10" VALVES. YOU MUST ORDER THE DISC ASSEMBLY.**

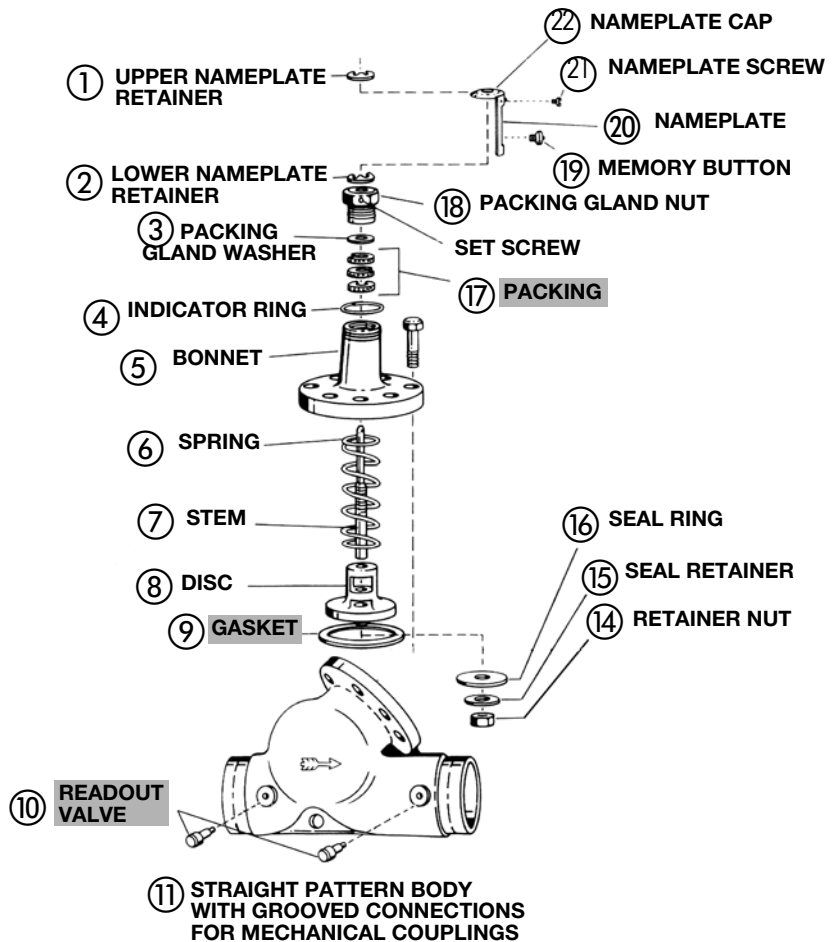

## MODELS WITH GROOVED CONNECTIONS

| ITEM NO. | DESCRIPTION               | 3DS-2G<br>132150   | 3DS-2 1/2G<br>132151 | 3DS-3G<br>132152 | 3DS-4G<br>132153  | 3DS-5G<br>132154 | 3DS-6G<br>132155 | 3DS-8G<br>132156 | 3DS-10G<br>132157 | 3DS-12G<br>132158 |  |
|----------|---------------------------|--|----------------------|------------------|-------------------|------------------|------------------|------------------|-------------------|-------------------|--|
| 10       | Readout Valve Set         | G97030 (or Readout Valve model RV-125A, P/N 113100 [50 pairs per package]) |                      |                  |                   |                  |                  |                  |                   |                   |  |
|          | Readout Probe Set         | G97032 (or Readout Probe model RP-250B, P/N 113102 [6 pairs per package])  |                      |                  |                   |                  |                  |                  |                   |                   |  |
| 7        | Stem                      | V50922   |                      | V50924           | V50925            | V50926           | V50927           | V50928           | V50929            | V50930            |  |
| 8        | Disc Assembly*            | V51756   | V51757               | V51758           | V51759            | V51760           | V51761           | V51762           | V51764            | V56884**          |  |
| 16       | Seal Ring*                | V50932   | V50933               | V50934           | V50935            | V50936           | V50937           | V50938           | V50939            | V50940            |  |
| 15       | Seal Retainer*            | V50942   | V58164               |                  | V50945            | V50946           | V50947           | V50948           | V50949            | V50950            |  |
| 14       | Retainer Nut*             | J91634   |                      |                  | J91635            |                  |                  | J91636           |                   |                   |  |
| 6        | Spring                    | V50952   |                      | V50953           | V50954            |                  | V50955           | V50956           | V50957            | V50958            |  |
| 5        | Bonnet                    | V51811   |                      | V51813           | V51142            | V51815           | V51817           | V51819           | V51821            | V51841            |  |
| 9        | Gasket                    | F27800   |                      | F19000           | V29400            | V32801           | V33001           | V35000           | V36400            | V36401            |  |
| 17       | Packing                   | F17000 (1 Piece)   |                      |                  | V51096 (3 Pieces) |                  |                  | V51097 (4)       |                   |                   |  |
| 18       | Packing Gland Nut         | F16600   |                      |                  | V51281            |                  |                  | V51183           |                   |                   |  |
| 3        | Packing Gland Washer      | NONE   |                      |                  | V51282            |                  |                  | V51184           |                   |                   |  |
| 11       | Body                      | V50818   | V50819               | V50820           | V18802            | V50821           | V50822           | V50823           | V50824            | V50825            |  |
| 20       | Nameplate                 | V51823   | V51824               | V51825           | V51826            | V51827           | V51828           | V51829           | V51830            | V51831            |  |
| 1        | Upper Nameplate Retainer  | V51090   |                      |                  | V51091            |                  |                  | V51092           |                   |                   |  |
| 2        | Lower Nameplate Retainer  | V51093   |                      |                  | V51094            |                  |                  | V51095           |                   |                   |  |
| 22       | Nameplate Cap             | V51111   |                      |                  | V51114            |                  |                  | V51119           |                   |                   |  |
| 21       | Nameplate Screw (2 req'd) | J92135   |                      |                  |                   |                  |                  |                  |                   |                   |  |
| 4        | Indicator Ring            | V51180   |                      |                  | V51181            |                  |                  | J94171           |                   |                   |  |
| 19       | Memory Button             | V56879   |                      |                  | V56880            |                  |                  |                  |                   |                   |  |

\*Disc Assembly for valves 2" through 10" includes disc, seal ring, seal retainer, and retainer nut. Disc Assembly not available for 3DS-12G.

\*\*Disc only.

■ – Factory recommended spare parts.

# PARTS FOR TRIPLE DUTY VALVES (CONTINUED)



**ASSEMBLED TRIPLE DUTY VALVE**

**NOTE: DISC IS NOT AVAILABLE SEPARATELY. YOU MUST ORDER THE DISC ASSEMBLY.**

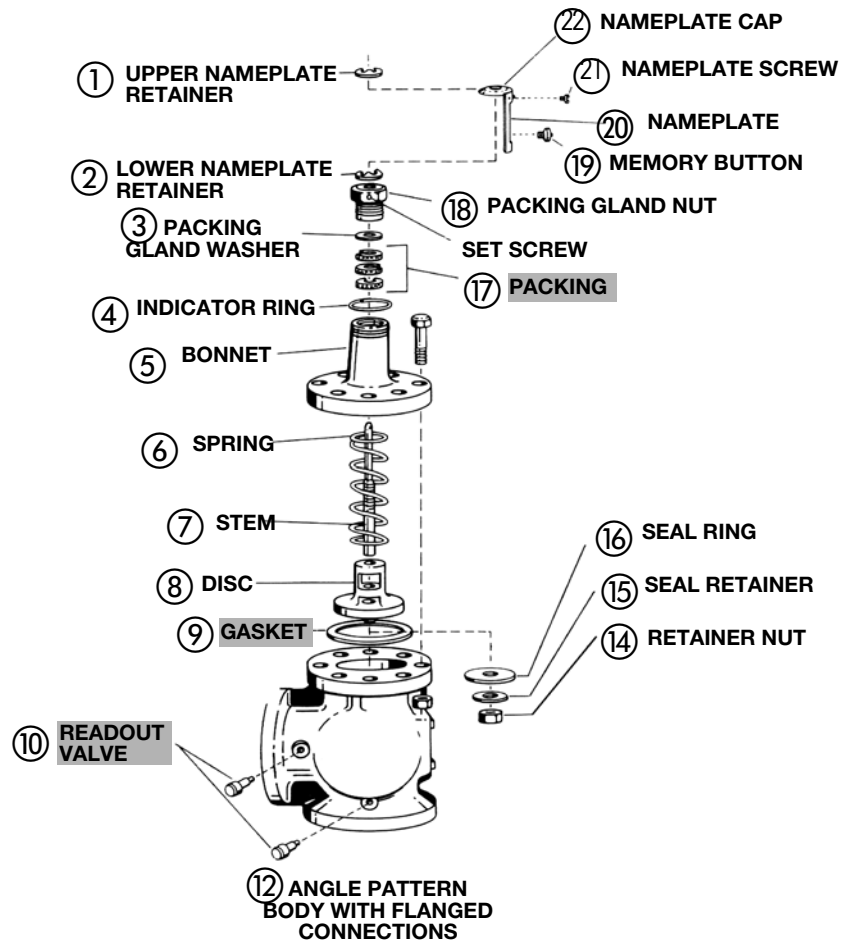

## ANGLE PATTERN MODELS

| ITEM NO. | DESCRIPTION               | 3D-2S<br>132131  | 3D-2 <sup>1</sup> / <sub>2</sub> S<br>132132 | 3D-3S<br>132133 | 3D-4S<br>132134   | 3D-5S<br>132135 | 3D-6S<br>132136 | 3D-8S<br>132137 | 3D-10S<br>132138 |
|----------|---------------------------|--|--|-----------------|-------------------|-----------------|-----------------|-----------------|------------------|
| 10       | Readout Valve Set         | G97030 (or Readout Valve model RV-125A, P/N 113100 [50 pairs per package]) |  |                 |                   |                 |                 |                 |                  |
|          | Readout Probe Set         | G97032 (or Readout Probe model RP-250B, P/N 113102 [6 pairs per package])  |  |                 |                   |                 |                 |                 |                  |
| 7        | Stem                      | V50922   |  | V50924          | V50925            | V50926          | V50927          | V50928          | V50929           |
| 8        | Disc Assembly*            | V51756   |  | V51758          | V51759            | V51760          | V51761          | V51762          | V51763           |
| 16       | Seal Ring*                | V50932   |  | V50934          | V50935            | V50936          | V50937          | V50938          | V50939           |
| 15       | Seal Retainer*            | V50942   |  | V58164          | V50945            | V50946          | V50947          | V50948          | V50949           |
| 14       | Retainer Nut*             | J91634   |  |                 | J91635            |                 |                 | J91636          |                  |
| 6        | Spring                    | V50952   |  | V50953          | V50954            |                 | V50955          | V50956          | V50957           |
| 5        | Bonnet                    | V51122   |  | V51126          | V51128            | V51130          | V51132          | V51134          | V51136           |
| 9        | Gasket                    | F27800   |  | F19000          | V29400            | V32801          | V33001          | V35000          | V36400           |
| 17       | Packing                   | F17000 (1 Piece)   |  |                 | V51096 (3 Pieces) |                 |                 |                 |                  |
| 18       | Packing Gland Nut         | F16600   |  |                 | V51281            |                 |                 |                 |                  |
| 3        | Packing Gland Washer      | NONE   |  |                 | V51282            |                 |                 |                 |                  |
| 12       | Body                      | V50810   | V50811                                       | V50812          | V50813            | V50814          | V50815          | V50816          | V50817           |
| 20       | Nameplate                 | V50971   | V50972                                       | V50973          | V50974            | V50975          | V50976          | V50977          | V50978           |
| 1        | Upper Nameplate Retainer  | V51090   |  |                 | V51091            |                 |                 |                 |                  |
| 2        | Lower Nameplate Retainer  | V51093   |  |                 | V51094            |                 |                 |                 |                  |
| 22       | Nameplate Cap             | V51111   |  |                 | V51114            |                 |                 |                 |                  |
| 21       | Nameplate Screw (2 req'd) |  |  |                 | J92135            |                 |                 |                 |                  |
| 4        | Indicator Ring            | V51180   |  |                 | V51181            |                 |                 |                 |                  |
| 19       | Memory Button             | V56879   |  |                 | V56880            |                 |                 |                 |                  |

\*Disc Assembly includes disc, seal ring, seal retainer, and retainer nut.

■ - Factory recommended spare parts.

# PARTS FOR TRIPLE DUTY VALVES (CONTINUED)



**ASSEMBLED TRIPLE DUTY VALVE**

**NOTE: DISC IS NOT AVAILABLE SEPARATELY ON 2" THROUGH 10" VALVES. YOU MUST ORDER THE DISC ASSEMBLY.**

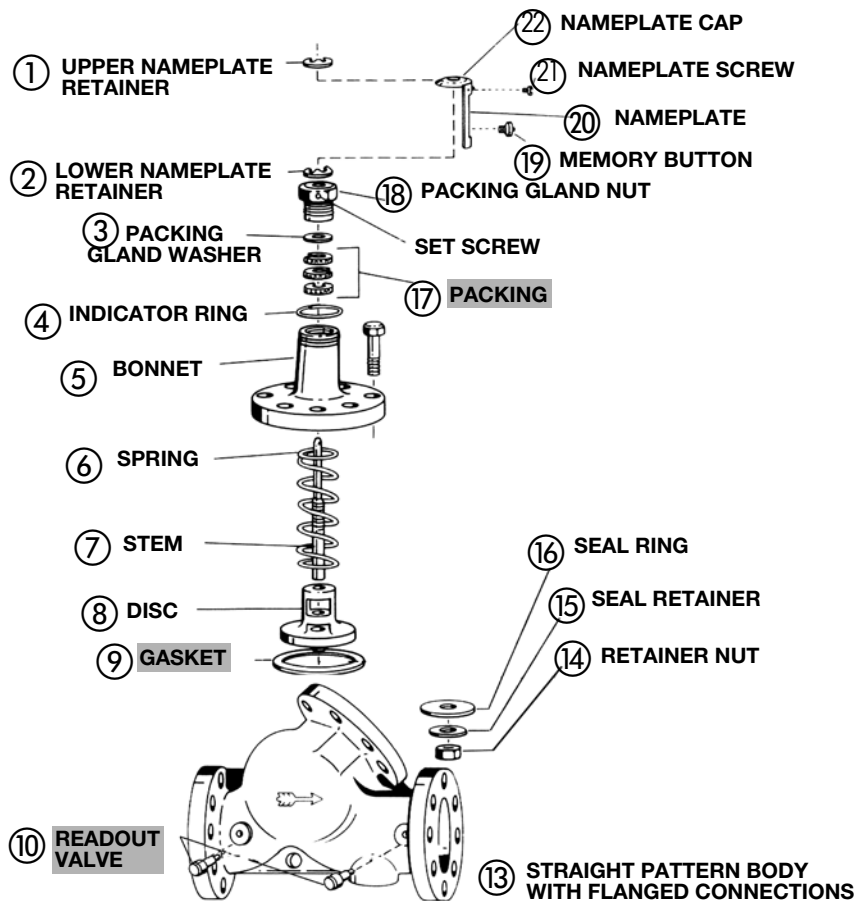

## STRAIGHT PATTERN MODELS

| ITEM NO. | DESCRIPTION               | 3DS-2S<br>132121   | 3DS-2 1/2 S<br>132122 | 3DS-3S<br>132123 | 3DS-4S<br>132124 | 3DS-5S<br>132125  | 3DS-6S<br>132126 | 3DS-8S<br>132127 | 3DS-10S<br>132128 | 3DS-12S<br>132129 | 3DS-14S<br>132120 |  |
|----------|---------------------------|--|-----------------------|------------------|------------------|-------------------|------------------|------------------|-------------------|-------------------|-------------------|--|
| 10       | Readout Valve Set         | G97030 (or Readout Valve model RV-125A, P/N 113100 [50 pairs per package]) |                       |                  |                  |                   |                  |                  |                   |                   |                   |  |
|          | Readout Probe Set         | G97032 (or Readout Probe model RP-250B, P/N 113102 [6 pairs per package])  |                       |                  |                  |                   |                  |                  |                   |                   |                   |  |
| 7        | Stem                      | V50922   |                       | V50924           | V50925           | V50926            | V50927           | V50928           | V50929            | V50930            | V50778            |  |
| 8        | Disc Assembly*            | V51756   | V51757                | V51758           | V51759           | V51760            | V51761           | V51762           | V51763            | V50920**          | V50754**          |  |
| 16       | Seal Ring*                | V50932   | V50933                | V50934           | V50935           | V50936            | V50937           | V50938           | V50939            | V50940            | V50793            |  |
| 15       | Seal Retainer*            | V50942   | V58164                |                  | V50945           | V50946            | V50947           | V50948           | V50949            | V50950            | V50750            |  |
| 14       | Retainer Nut*             | J91634   |                       |                  | J91635           |                   |                  | J91636           |                   |                   | J91637            |  |
| 6        | Spring                    | V50952   |                       | V50953           | V50954           |                   | V50955           | V50956           | V50957            | V50958            | V51083            |  |
| 5        | Bonnet                    | V51122   |                       | V51126           | V51128           | V51130            | V51132           | V51134           | V51136            | V51138            | V51140            |  |
| 9        | Gasket                    | F27800   |                       | F19000           | V29400           | V32801            | V33001           | V35000           | V36400            | V36401            | V36402            |  |
| 17       | Packing                   | F17000 (1 Piece)   |                       |                  |                  | V51096 (3 Pieces) |                  |                  |                   | V51097 (4 Pieces) |                   |  |
| 18       | Packing Gland Nut         | F16600   |                       |                  |                  | V51281            |                  |                  |                   | V51183            |                   |  |
| 3        | Packing Gland Washer      | NONE   |                       |                  |                  | V51282            |                  |                  |                   | V51184            |                   |  |
| 13       | Body                      | V50830   | V50831                | V50832           | V50833           | V50834            | V50835           | V50836           | V50837            | V50838            | V50839            |  |
| 20       | Nameplate                 | V50961   | V50962                | V50963           | V50964           | V50965            | V50966           | V50967           | V50968            | V50969            | V50896            |  |
| 1        | Upper Nameplate Retainer  | V51090   |                       |                  |                  | V51091            |                  |                  |                   | V51092            |                   |  |
| 2        | Lower Nameplate Retainer  | V51093   |                       |                  |                  | V51094            |                  |                  |                   | V51095            |                   |  |
| 22       | Nameplate Cap             | V51111   |                       |                  |                  | V51114            |                  |                  |                   | V51119            |                   |  |
| 21       | Nameplate Screw (2 req'd) | J92135   |                       |                  |                  |                   |                  |                  |                   |                   |                   |  |
| 4        | Indicator Ring            | V51180   |                       |                  |                  | V51181            |                  |                  |                   | J94171            |                   |  |
| 19       | Memory Button             | V56879   |                       |                  |                  | V56880            |                  |                  |                   |                   |                   |  |

\*Disc Assembly for valves 2" through 10" includes disc, seal ring, seal retainer, and retainer nut. Disc Assembly not available for 3DS-12S and 3DS-14S.

\*\*Disc only.

■ - Factory recommended spare parts.

# PARTS FOR TRIPLE DUTY VALVES – REDUCED PORT

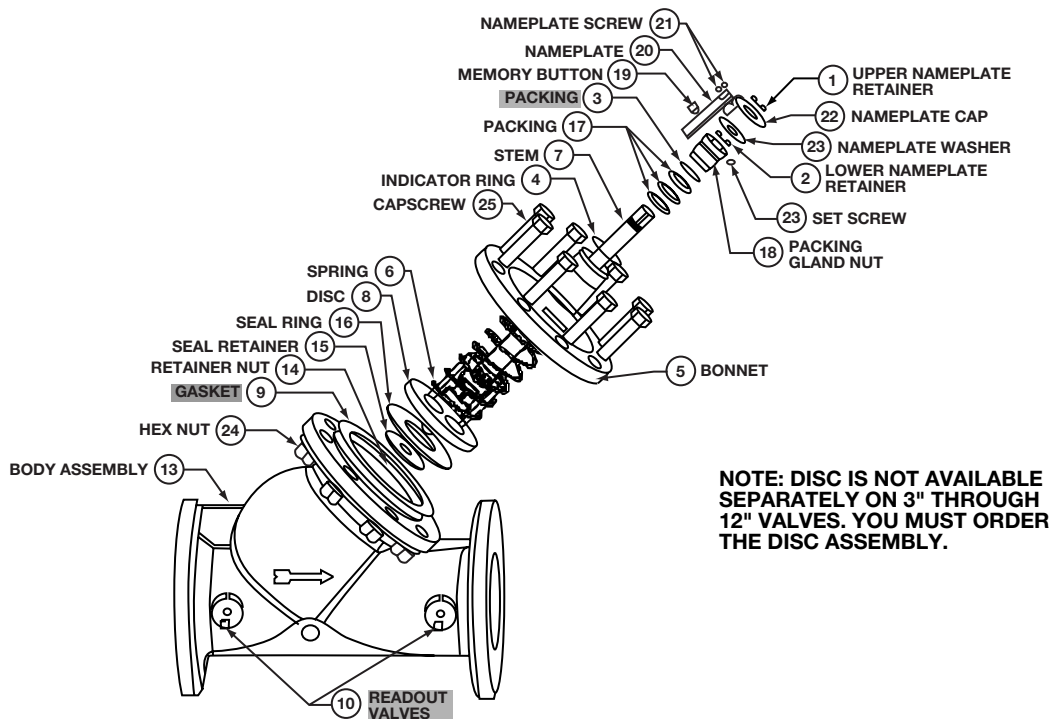

| ITEM NO. | DESCRIPTION               | 3DS-3B<br>132160   | 3DS-4B<br>132161 | 3DS-5B<br>132162 | 3DS-6B<br>132163    | 3DS-8B<br>132164    | 3DS-10B<br>132165 | 3DS-12B<br>132166   | 3DS-14B<br>132167    | 3DS-16B<br>132168    |        |
|----------|---------------------------|--|------------------|------------------|---------------------|---------------------|-------------------|---------------------|----------------------|----------------------|--------|
| 10       | Readout Valve Set         | G97030 (or Readout Valve model RV-125A, P/N 113100 [50 pairs per package]) |                  |                  |                     |                     |                   |                     |                      |                      |        |
|          | Readout Probe Set         | G97032 (or Readout Probe model RP-250B, P/N 113102 [6 pairs per package])  |                  |                  |                     |                     |                   |                     |                      |                      |        |
| 13       | Body                      | V51958   | V51961           | V51964           | V51967              | V51970              | V51973            | V51976              | V51979               | V51982               |        |
| 9        | Gasket                    | F27800   | F19000           | V29400           | V32801              | V33001              | V35000            | V36400              | V36401               | V36402               |        |
| 5        | Bonnet                    | V51122   | V51126           | V51128           | V51130              | V51132              | V51134            | V51136              | V51138               | V51140               |        |
| 7        | Stem                      | V50922   | V50924           | V50925           | V50926              | V50927              | V50928            | V50929              | V50930               | V50778               |        |
| 18       | Packing Gland Nut         | F16600   |                  |                  |                     | V51281              |                   |                     | V51183               |                      |        |
| 3        | Packing Gland Washer      | NONE   |                  |                  |                     | V51282              |                   |                     | V51184               |                      |        |
| 6        | Spring                    | V50952   | V50953           | V50954           |                     | V50955              | V50956            | V50957              | V50958               | V51083               |        |
| 17       | Packing                   | F17000   |                  |                  | V51096 (3 pieces)   |                     |                   |                     | V51097 (4 pieces)    |                      |        |
| 19       | Memory Button             | V56879   |                  |                  |                     | V56880              |                   |                     |                      |                      |        |
| 20       | Nameplate                 | V57089   | V57090           | V57091           | V57092              | V57093              | V57094            | V57095              | V57096               | V57097               |        |
| 22       | Nameplate Cap             | V51111   |                  |                  |                     | V51114              |                   |                     | V51119               |                      |        |
| 21       | Nameplate Screw (2 req'd) |  |                  |                  |                     |                     |                   | J92135              |                      |                      |        |
| 1        | Upper Nameplate Retainer  | V51090   |                  |                  |                     | V51091              |                   |                     | V51092               |                      |        |
| 2        | Lower Nameplate Retainer  | V51093   |                  |                  |                     | V51094              |                   |                     | V51095               |                      |        |
| 4        | Indicator Ring            | V51180   |                  |                  |                     | V51181              |                   |                     |                      |                      |        |
| 8        | Disc Assembly*            | V51757   | V51758           | V51759           | V51760              | V51761              | V51762            | V51763              | V50920**             | V50754**             |        |
| 16       | Seal Ring*                | V50933   | V50934           | V50935           | V50936              | V50937              | V50938            | V50939              | V50940               | V50793               |        |
| 15       | Seal Retainer*            | V58164   |                  |                  | V50945              | V50946              | V50947            | V50948              | V50949               | V50950               | V50750 |
| 14       | Retainer Nut*             | J91634   |                  |                  | J91635              |                     |                   |                     |                      |                      |        |
| 24       | Cap screw                 | NONE   |                  |                  | J92017<br>(8 req'd) | M06690<br>(8 req'd) |                   | DJ0157<br>(8 req'd) | M06720<br>(10 req'd) | DJ0157<br>(12 req'd) |        |
| 25       | Hex Nut                   | NONE   |                  |                  | T33740<br>(8 req'd) | T35840<br>(8 req'd) |                   |                     | T39830<br>(10 req'd) | T35840<br>(12 req'd) |        |

■ – Factory recommended spare part.

\* Disc Assembly for 3" through 12" valves includes disc, seal ring, seal retainer and retainer nut. Disc Assembly not available for 3DS-14B and 3DS-16B.

\*\*Disc only.

# PARTS FOR SUCTION DIFFUSERS



**SUCTION DIFFUSER  
W/ GROOVED CONNECTIONS**



**ASSEMBLED SUCTION  
DIFFUSER**

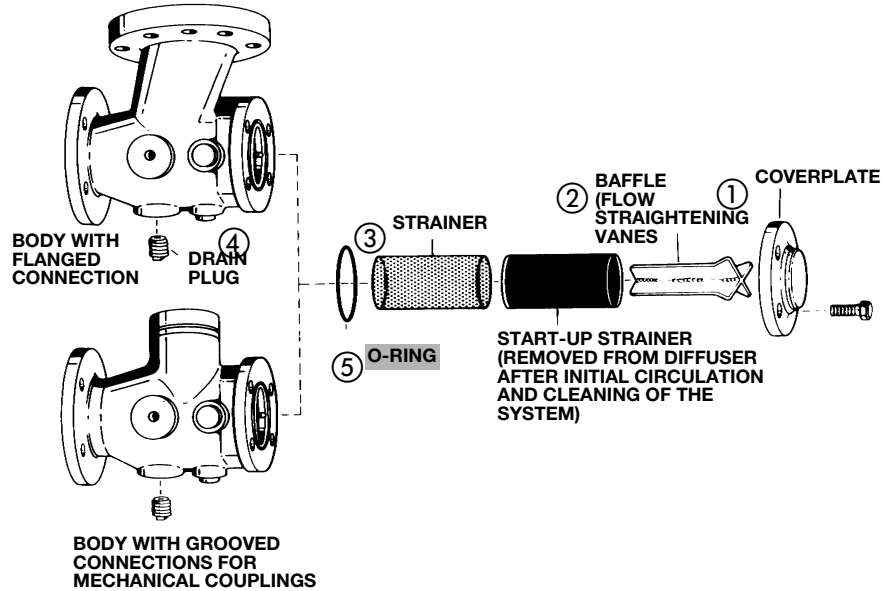

## MODELS WITH NPT OR FLANGED CONNECTIONS

| ITEM NO.                           | MODEL | "X" MODELS WITH STEEL COMPONENTS |        |          | "Z" MODELS WITH STAINLESS STEEL COMPONENTS |        |             | 5      | 1           | 4          | START-UP STRAINER PART NO. |
|------------------------------------|-------|----------------------------------|--------|----------|--|--------|-------------|--------|-------------|------------|----------------------------|
|                                    |       | 2                                | 3      | 2        | 3  | O-RING | COVER-PLATE |        |             |            |                            |
| SIZE                               | MODEL | PART NO.                         | BAFFLE | STRAINER | PART NO.                                   | BAFFLE | STRAINER    | O-RING | COVER-PLATE | DRAIN PLUG | START-UP STRAINER PART NO. |
| 2x1 <sup>1/2</sup>                 | BA-3  | 115019                           | A91554 | A91270   | 115060                                     | A91563 | A91280      | J94140 | A91242      | M06420     | A91260                     |
| 2x2                                | BB-3  | 115036                           | A91555 | A91271   | 115050                                     | A91564 | A91281      | J94141 | A91244      | M06420     | A91261                     |
| 2 <sup>1/2</sup> x2                | CB-3  | 115037                           | A91555 | A91271   | 115051                                     | A91564 | A91281      | J94141 | A91244      | M06420     | A91261                     |
| 2 <sup>1/2</sup> x2 <sup>1/2</sup> | CC-3  | 115038                           | A91556 | A91278   | 115052                                     | A07029 | A91288      | J94141 | A91244      | M06420     | A91268                     |
| 3x1 <sup>1/2</sup>                 | DA-3  | 115021                           | A91555 | A91271   | 115061                                     | A91564 | A91281      | J94141 | A91244      | M06420     | A91261                     |
| 3x2                                | DB-3  | 115022                           | A91555 | A91271   | 115062                                     | A91564 | A91281      | J94141 | A91244      | M06420     | A91261                     |
| 3x2 <sup>1/2</sup>                 | DC-3  | 115039                           | A91556 | A91278   | 115053                                     | A07029 | A91288      | J94141 | A91244      | M06420     | A91268                     |
| 3x3                                | DD-3  | 115024                           | A91557 | A91272   | 115063                                     | A07030 | A91282      | J94130 | A91246      | M06420     | A91262                     |
| 4x2 <sup>1/2</sup>                 | EC-3  | 115075                           | A91556 | A91278   | 115076                                     | A07029 | A91288      | J94141 | A91244      | M06420     | A91268                     |
| 4x3                                | ED-3  | 115025                           | A91557 | A91272   | 115064                                     | A07030 | A91282      | J94130 | A91246      | M06420     | A91262                     |
| 4x4                                | EE-3  | 115026                           | A91558 | A91273   | 115065                                     | A07031 | A91283      | J94131 | A91248      | M06420     | A91263                     |
| 5x4                                | FE-3  | 115027                           | A91558 | A91273   | 115066                                     | A07031 | A91283      | J94131 | A91248      | M06420     | A91263                     |
| 5x5                                | FF-3  | 115029                           | A91559 | A91274   | 115068                                     | A07032 | A91284      | J94142 | A91250      | M06420     | A91264                     |
| 6x4                                | GE-3  | 115028                           | A91558 | A91273   | 115067                                     | A07031 | A91283      | J94131 | A91248      | M06420     | A91263                     |
| 6x5                                | GF-3  | 115030                           | A91559 | A91274   | 115069                                     | A07032 | A91284      | J94142 | A91250      | M06420     | A91264                     |
| 6x6                                | GG-3  | 115031                           | A91560 | A91275   | 115070                                     | A07033 | A91285      | J94143 | A91252      | M06420     | A91265                     |
| 8x6                                | HG-3  | 115032                           | A91560 | A91275   | 115071                                     | A07033 | A91285      | J94143 | A91252      | M06420     | A91265                     |
| 8x8                                | HH-3  | 115033                           | A91561 | A91276   | 115072                                     | A07034 | A91286      | J94144 | A91254      | M06420     | A91266                     |
| 10x8                               | JH-3  | 115035                           | A91561 | A91276   | 115074                                     | A07034 | A91286      | J94144 | A91254      | M06420     | A91266                     |
| 10x10                              | JJ-3  | 115034                           | A91562 | A91277   | 115073                                     | A07035 | A91287      | J94145 | A91256      | M06420     | A91267                     |

## MODELS WITH GROOVED CONNECTIONS

| ITEM NO. | MODEL NO.            | PART NO. | 2      | 3        | 5      | 1          | 4          | START-UP STRAINER PART NO. |
|----------|----------------------|----------|--------|----------|--------|------------|------------|----------------------------|
|          |                      |          | BAFFLE | STRAINER | O-RING | COVERPLATE | DRAIN PLUG |                            |
|          | SDG-2 <sup>1/2</sup> | 115040   | A07029 | A91288   | J94141 | A07016     | M06420     | A91268                     |
|          | SDG-3                | 115041   | A07030 | A91282   | J94130 | A07018     | M06420     | A91262                     |
|          | SDG-4                | 115042   | A07031 | A91283   | J94131 | A07020     | M06420     | A91263                     |
|          | SDG-5                | 115043   | A07032 | A91284   | J94142 | A07022     | M06420     | A91264                     |
|          | SDG-6                | 115044   | A07033 | A91285   | J94143 | A07024     | M06420     | A91265                     |
|          | SDG-8                | 115045   | A07034 | A91286   | J94144 | A07026     | M06420     | A91266                     |
|          | SDG-10               | 115046   | A07035 | A91287   | J94145 | A07028     | M06420     | A91267                     |

■ - Factory recommended spare parts.

## “WHERE USED” LIST

| CATEGORY                       | PART NO. | WHERE USED  | NOTES/SPECIFICATION   |
|--------------------------------|----------|---|---|
| <b>POWER PACK &amp; MOTORS</b> | 111031   | PR, Obs. 1", Obs. 1 <sup>1</sup> / <sub>4</sub> ", Obs. 1 <sup>1</sup> / <sub>2</sub> ", Obs. 2", Obs. HV   | 1/6HP, 1PH, 115V  |
|                                | 111033   | PR, Obs. 1", Obs. 1 <sup>1</sup> / <sub>4</sub> ", Obs. 1 <sup>1</sup> / <sub>2</sub> ", Obs. 2", Obs. HV   | 1/6HP, 1PH, 230V  |
|                                | 111034   | Series 100  | 1/2HP, 1PH, 115V  |
|                                | 111035   | Series 100  | 1/2HP, 1PH, 230V  |
|                                | 111039   | Obs. 1", Obs. 1 <sup>1</sup> / <sub>4</sub> ", Obs. 1 <sup>1</sup> / <sub>2</sub> ", Obs. 2", Obs. HV   | 1/6HP, 3PH, 208-230/460V                                      |
|                                | 111040   | 2 <sup>1</sup> / <sub>2</sub> ", LD-3   | 1/4HP, 1PH, 115V  |
|                                | 111041   | 2 <sup>1</sup> / <sub>2</sub> ", LD-3   | 1/4HP, 1PH, 230V  |
|                                | 111042   | HD-3  | 1/3HP, 1PH, 115/230V  |
|                                | 111044   | PD-35S, 60-13S, 60-B13S, 60-15S, 60 1AA, 60 1 <sup>1</sup> / <sub>4</sub> "AA, 60 1 <sup>1</sup> / <sub>2</sub> "AA, 60 2AA, 60 1 <sup>1</sup> / <sub>2</sub> "A, 60 2A Obs. 60-3S, Obs. 60-5S  | 1/2HP, 1PH, 115/230V  |
|                                | 111046   | PD-35T, 60-13T, 60-B13T, 60-15T, 60 1AA, 60 1 <sup>1</sup> / <sub>4</sub> "AA, 60 1 <sup>1</sup> / <sub>2</sub> "AA, 60 2AA, 60 1 <sup>1</sup> / <sub>2</sub> "A, 60 2A, Obs. 60-3T, Obs. 60-5T | 1/2HP, 3PH, 208-230/460V                                      |
|                                | 111047   | PD-37S, 60-14S, 60-B14S, 60-16S, 60 1 <sup>1</sup> / <sub>2</sub> "AA, 60 2AA, 60 1 <sup>1</sup> / <sub>2</sub> "A, 60 2A, Obs. 60-4S, Obs. 60-6S, Obs. 60-8S                                   | 3/4HP, 1PH, 115/230V  |
|                                | 111049   | PD-37T, 60-14T, 60-B14T, 60-16T, 60 1 <sup>1</sup> / <sub>2</sub> "AA, 60 2AA, 60 1 <sup>1</sup> / <sub>2</sub> "A, 60 2A, Obs. 60-4T, Obs. 60-6T   | 3/4HP, 3PH, 208-230/460V                                      |
|                                | 111061   | HV, 2", Obs. 1 <sup>1</sup> / <sub>2</sub> ", Obs. HV   | 1/6HP, 1PH, 115V  |
|                                | 169035   | 60-10S, 60-11S, 60B-11S, 60 1AA, 60 1 <sup>1</sup> / <sub>4</sub> "AA, 60 1 <sup>1</sup> / <sub>2</sub> "AA, 60 2AA, Obs. 60-1S   | 1/4HP, 1PH, 115V  |
|                                | 169036   | 60-10S, 60-11S, 60B-11S, 60 1AA, 60 1 <sup>1</sup> / <sub>4</sub> "AA, 60 1 <sup>1</sup> / <sub>2</sub> "AA, 60 2AA   | 1/4HP, 1PH, 230V  |
|                                | 169037   | 60-11T, 60 1AA, 60 1 <sup>1</sup> / <sub>4</sub> "AA, 60 1 <sup>1</sup> / <sub>2</sub> "AA, 60 2AA, Obs. 60-1T  | 1/4HP, 3PH, 208-230/460V                                      |
|                                | 169038   | 60 1AA, 60 1 <sup>1</sup> / <sub>4</sub> "AA, 60 1 <sup>1</sup> / <sub>2</sub> "AA, 60 2AA, Obs. 60-2S  | 1/3HP, 1PH, 115/230V  |
|                                | 169039   | 60 1AA, 60 1 <sup>1</sup> / <sub>4</sub> "AA, 60 1 <sup>1</sup> / <sub>2</sub> "AA, 60 2AA, Obs. 60-2T  | 1/3HP, 3PH, 208-230/460V                                      |
|                                | 169040   | 1522 1S, 3/4AAB, 1522 1AAB, 1522 1 <sup>1</sup> / <sub>4</sub> "AAB, 1522 1 <sup>1</sup> / <sub>2</sub> "AAB  | 1/4HP, 1PH, 115V  |
|                                | 169041   | 1522 3/4AAB, 1522 1AAB, 1522 1 <sup>1</sup> / <sub>4</sub> "AAB, 1522 1 <sup>1</sup> / <sub>2</sub> "AAB  | 1/4HP, 1PH, 230V  |
|                                | 169042   | 1522 1T, 1522 3/4AAB, 1522 1AAB, 1522 1 <sup>1</sup> / <sub>4</sub> "AAB, 1522 1 <sup>1</sup> / <sub>2</sub> "AAB   | 1/4HP, 3PH, 208-230/460V                                      |
|                                | 169043   | 1522 2S, 1522 3/4AAB, 1522 1AAB, 1522 1 <sup>1</sup> / <sub>4</sub> "AAB, 1522 1 <sup>1</sup> / <sub>2</sub> "AAB   | 1/3HP, 1PH, 115/230V  |
|                                | 169044   | Obs. 1522 14S, Obs. 1522 3/4AAB   | 1/3HP, 1PH, 115/230V, 3450 RPM                                |
|                                | 169045   | 1522 2T, 1522 3/4AAB, 1522 1AAB, 1522 1 <sup>1</sup> / <sub>4</sub> "AAB, 1522 1 <sup>1</sup> / <sub>2</sub> "AAB   | 1/3HP, 3PH, 208-230/460V                                      |
|                                | 169046   | Obs. 1522 14T, Obs. 1522 3/4AAB   | 1/3HP, 3PH, 208-230/460V, 3450 RPM                            |
|                                | 169047   | 1522 3S, 1522 3/4AAB, 1522 1AAB, 1522 1 <sup>1</sup> / <sub>4</sub> "AAB, 1522 1 <sup>1</sup> / <sub>2</sub> "AAB   | 1/2HP, 1PH, 115/230V  |
|                                | 169048   | Obs. 1522 5S, Obs. 1522 3/4AAB, Obs. 1522 1AAB  | 1/2HP, 1PH, 115/230V, 3450 RPM                                |
|                                | 169049   | 1522 3T, 1522 3/4AAB, 1522 1AAB, 1522 1 <sup>1</sup> / <sub>4</sub> "AAB, 1522 1 <sup>1</sup> / <sub>2</sub> "AAB   | 1/2HP, 3PH, 208-230/460V                                      |
|                                | 169050   | Obs. 1522 5T, Obs. 1522 3/4AAB, Obs. 1522 1AAB  | 1/2HP, 3PH, 208-230/460V, 3450 RPM                            |
|                                | 169051   | 1522 4S, 1522 1 <sup>1</sup> / <sub>4</sub> "AAB, 1522 1 <sup>1</sup> / <sub>2</sub> "AAB   | 3/4HP, 1PH, 115/230V  |
|                                | 169052   | Obs. 1522 6S, Obs. 1522 7S, Obs. 1522 3/4AAB, Obs. 1522 1AAB, Obs. 1522 1 <sup>1</sup> / <sub>4</sub> "AAB  | 3/4HP, 1PH, 115/230, 3450 RPM                                 |
|                                | 169053   | 1522 4T, 1522 1 <sup>1</sup> / <sub>4</sub> "AAB, 1522 1 <sup>1</sup> / <sub>2</sub> "AAB   | 3/4HP, 3PH, 208-230/460V                                      |
|                                | 169054   | Obs. 1522 6T, Obs. 1522 7T, Obs. 3/4AAB, Obs. 1522 1AAB, Obs. 1522 1 <sup>1</sup> / <sub>4</sub> "AAB   | 3/4HP, 3PH, 208-230/460V, 3450 RPM                            |
|                                | 169055   | Obs. 1522 8S, Obs. 1522 12S, Obs. 1522 3/4AAB, Obs. 1522 1AAB, Obs. 1522 1 <sup>1</sup> / <sub>4</sub> "AAB, Obs. 1522 1 <sup>1</sup> / <sub>2</sub> "AAB                                       | 1HP, 1PH, 115/230V, 3450 RPM                                  |
|                                | 169056   | Obs. 1522 8T, Obs. 1522 12T, Obs. 1522 3/4AAB, Obs. 1522 1AAB, Obs. 1522 1 <sup>1</sup> / <sub>4</sub> "AAB, Obs. 1522 1 <sup>1</sup> / <sub>2</sub> "AAB                                       | 1HP, 3PH, 208-230/460V, 3450 RPM                              |
|                                | 169057   | Obs. 1522 9S, Obs. 1522 16S, Obs. 1522 17S, Obs. 1522 3/4AAB, Obs. 1522 1AAB, Obs. 1522 1 <sup>1</sup> / <sub>4</sub> "AAB, Obs. 1522 1 <sup>1</sup> / <sub>2</sub> "AAB                        | 1 <sup>1</sup> / <sub>2</sub> HP, 1PH, 230V, 3450 RPM         |
|                                | 169058   | Obs. 1522 9T, Obs. 1522 16T, Obs. 1522 17T, Obs. 1522 3/4AAB, Obs. 1522 1AAB, Obs. 1522 1 <sup>1</sup> / <sub>4</sub> "AAB, Obs. 1522 1 <sup>1</sup> / <sub>2</sub> "AAB                        | 1 <sup>1</sup> / <sub>2</sub> HP, 3PH, 208-230/460V, 3450 RPM |
|                                | 169060   | Obs. 1522 11T, Obs. 1522 15T, Obs. 1522 3/4AAB, Obs. 1522 1AAB, Obs. 60 1 <sup>1</sup> / <sub>4</sub> "AAB, Obs. 1522 1 <sup>1</sup> / <sub>2</sub> "AAB  | 2HP, 3PH, 208-230/460V, 3450 RPM                              |
|                                | 169221   | 60 2 <sup>1</sup> / <sub>2</sub> "F   | 3HP, 3PH, 208-230/460V, 145TC Frame                           |
|                                | 169222   | 60 2 <sup>1</sup> / <sub>2</sub> "F   | 3HP, 3PH, 200V, 182TC Frame                                   |
|                                | 169223   | 60 2 <sup>1</sup> / <sub>2</sub> "F   | 3HP, 3PH, 208-230/460V, 182TC Frame                           |
|                                | 169224   | MF 60 1 x 5 <sup>1</sup> / <sub>4</sub> ", MF 60 1 <sup>1</sup> / <sub>4</sub> x 5 <sup>1</sup> / <sub>4</sub> ", MF 60 1 <sup>1</sup> / <sub>2</sub> x 5 <sup>1</sup> / <sub>4</sub> "         | 1/4HP, 1PH, 115/208-230V, 1725 RPM                            |
|                                | 169225   | MF 60 1 x 5 <sup>1</sup> / <sub>4</sub> ", MF 60 1 <sup>1</sup> / <sub>4</sub> x 5 <sup>1</sup> / <sub>4</sub> "  | 1/4HP, 3PH, 208-230/460V, 1725 RPM                            |
|                                | 169226   | MF 60 with 5 <sup>1</sup> / <sub>4</sub> " impellers  | 1/3HP, 1PH, 115/208-230V, 1725 RPM                            |
|                                | 169227   | MF 60 with 5 <sup>1</sup> / <sub>4</sub> " impellers  | 1/3HP, 3PH, 208-230/460V, 1725 RPM                            |
|                                | 169228   | MF 60 with 5 <sup>1</sup> / <sub>4</sub> " & 6 <sup>1</sup> / <sub>4</sub> " impellers  | 1/2HP, 1PH, 115/208-230V, 1725 RPM                            |
|                                | 169229   | MF 60 with 5 <sup>1</sup> / <sub>4</sub> " & 6 <sup>1</sup> / <sub>4</sub> " impellers  | 1/2HP, 3PH, 208-230/460V, 1725 RPM                            |

\*All motors are 1725 RPM unless otherwise specified.

CF – contact factory for where used.

**NOTE:** Obs. = Obsolete Pump Model, MF = Maintenance Free

## “WHERE USED” LIST (CONTINUED)

| CATEGORY                           | PART NO.                           | WHERE USED  | NOTES/SPECIFICATION                            |
|------------------------------------|------------------------------------|---|--|
| POWER PACK & MOTORS<br>(CONTINUED) | 169230                             | All MF 60   | 3/4HP, 1PH, 115/208-230V, 1725 RPM             |
|                                    | 169231                             | All MF 60   | 3/4HP, 3PH, 208-230/460V, 1725 RPM             |
|                                    | 169232                             | All MF 60 except 1 x 5 1/4, 1 1/4 x 5 1/4, PD-38, PD-39                     | 1HP, 1PH, 115/208-230V, 1725 RPM               |
|                                    | 169233                             | All MF 60 except 1 x 5 1/4, 1 1/4 x 5 1/4, PD-38, PD-39                     | 1HP, 3PH, 208-230/460V, 1725 RPM               |
|                                    | 169234                             | MF 60 1 1/2 x 7, MF 60 2 x 7  | 3HP, 3PH, 208-230/460V, 1725 RPM               |
|                                    | 169236                             | All MF 60 except 1 x 5 1/4, 1 1/4 x 5 1/4, PD-40                            | 1 1/2HP, 1PH, 115/208-230V, 1725 RPM           |
|                                    | 169237                             | All MF 60 except 1 x 5 1/4, 1 1/4 x 5 1/4, PD-40                            | 1 1/2HP, 3PH, 115/208-230V, 1725 RPM           |
|                                    | 169238                             | MF 60 1 1/2 x 7, MF 60 2 x 7  | 2HP, 3PH, 208-230/460V, 1725 RPM               |
| MOTOR MOUNTS SETS                  | 118223                             | Series 100, HV, 2", PR, Obs. 1", Obs. 1 1/4", Obs. 1 1/2", Obs. 2", Obs. HV |  |
|                                    | 118228                             | 2 1/2", LD-3, HD-3, PD-35, PD-37, 60 "AA", 60 "A", 1522                     |  |
|                                    | 118848                             | PD-38, Obs. PD-39, Series 60, MF 60   |  |
| COUPLERS                           | 118473                             | PD-35, PD-37, 60 "AA", 1522, MF 60 with 5 1/4" and 6 1/4" impellers         | 1/2" x 1/2", spring type                       |
|                                    | 118635                             | PD-35, PD-37, 60 "AA", 1522   | 5/8" x 1/2", 3 piece type                      |
|                                    | 118705                             | Series 100, HV, 2", PR, Obs. 1", Obs. 1 1/4", Obs. 1 1/2", Obs. HV, Obs. 2" | Cast Iron, 1/2" x 1/2", spring type            |
|                                    | 118708                             | PD-35, PD-37, 60 "AA"   | 3/4" x 5/8", spring type                       |
|                                    | 118709                             | PD-35, PD-37, 60 "AA", 1522   | 5/8" x 1/2", spring type                       |
|                                    | 118723                             | 2 1/2", LD-3, HD-3, Obs. HLD-3, Obs. HHD-3                                  | 1/2" x 1/2", spring type                       |
|                                    | 118732                             | Obs. HV, Obs. 2", Obs. PR, Obs. 1", Obs. 1 1/4", Obs. 1 1/2"                | Reversing duty                                 |
|                                    | 185329                             | MF 60 with 5 1/4" & 6 1/4" impellers  |  |
|                                    | 185330                             | MF 60   |  |
|                                    | 185331                             | MF 60 with 7" impellers   |  |
|                                    | 186003                             | PD-40, 60 "A", 60 2 1/2F, MF 60 with 7" impellers                           | 5/8" Shaft Dia                                 |
|                                    | 186004                             | PD-38, Obs. PD-39, 60 "A", MF 60 with 7" impellers                          | 5/8" Shaft Dia                                 |
|                                    | 186410                             | PD-38, PD-40, Obs. PD-39, 60 "A"  | 5/8" x 1/2", spring type                       |
|                                    | 189110                             | Series 100, HV, 2", PR, Obs. 1", Obs. 1 1/4", Obs. 1 1/2", Obs. HV, Obs. 2" | Stamped Steel, 1/2" x 1/2", spring type        |
|                                    | P58598                             | MF 60 with 5 1/4" & 6 1/4" impellers  | 1/2" x 7/8", 3 piece                           |
|                                    | P62190                             | HV, 2", PR, Obs. 1", Obs. 1 1/4", Obs. 1 1/2"                               | Explosion Proof, 1/2" x 1/2", 3 piece          |
|                                    | P62320                             | 60 "AA"   | Explosion Proof, 7/8" x 1/2", 3 piece          |
|                                    | P75421                             | MF 60 with 5 1/4" & 6 1/4" impellers  | 1/2" x 5/8", 3 piece                           |
|                                    | P75422                             | MF 60 with 5 1/4" & 6 1/4" impellers  | 1/2" x 7/8", 3 piece                           |
|                                    | P77234                             | PD-35, PD-37, 60 "AA" 1522  | Explosion Proof, 1/2" x 1/2", 3 piece type     |
| P77237                             | 60 "A"                             | Explosion Proof, 1/2" x 5/8", 3 piece type                                  |  |
| P77279                             | 60-22T, 60 2 1/2F                  | Explosion Proof, 7/8" x 5/8", 3 piece type                                  |  |
| P77281                             | 60 2 1/2F, MF 60 with 7" impellers | Explosion Proof, 1 1/8" x 5/8", 3 piece type                                |  |
| COUPLER & RING MOUNT SETS          | 118474                             | PD-35, PD-37, 60 "AA", 60 "A", 1522   | 1/3-3/4HP power packs only                     |
|                                    | 118706                             | Series 100, HV, 2", PR  | Includes Cast Iron coupler                     |
|                                    | 118707                             | HV, PR, 2", Obs. 1 1/4", Obs. 1 1/2"  |  |
|                                    | 118724                             | 2 1/2", LD-3, HD-3  |  |
| BEARING ASSEMBLIES                 | 118844                             | Series 100  | Cast Iron models only                          |
|                                    | 185260                             | PD-38, PD-40, Obs. PD-39, 60 "A"  | Bronze Fitted models only                      |
|                                    | 185261                             | PD-38, PD-40, Obs. PD-39, 60 "A"  | All Iron models only                           |
|                                    | 185262                             | PD-38, PD-40, Obs. PD-39, 60 "A"  | Bronze models only                             |
|                                    | 185264                             | 60 2 1/2F   | Bronze Fitted models only                      |
|                                    | 185265                             | 60 2 1/2F   | Bronze models only                             |
|                                    | 185332                             | MF 60 with 5 1/4" & 6 1/4" impellers  | Copper Shaft Sleeve, Buna-N seal               |
|                                    | 185333                             | MF 60 with 7" impellers, PD-38, PD-40                                       | Copper Shaft Sleeve, Buna-N seal               |
|                                    | 185334                             | MF 60 with 7" impellers, PD-38, PD-40                                       | Copper Shaft Sleeve, Buna-N seal               |
|                                    | 185355                             | MF 60 with 5 1/4" & 6 1/4" impellers  | Copper Shaft Sleeve, EPT seal                  |
|                                    | 185356                             | MF 60 with 5 1/4" & 6 1/4" impellers  | Copper Shaft Sleeve, Viton seal                |
|                                    | 185357                             | MF 60 with 5 1/4" & 6 1/4" impellers  | Stn. Stl. Shaft Sleeve, Buna-N seal            |
|                                    | 185358                             | MF 60 with 5 1/4" & 6 1/4" impellers  | Stn. Stl. Shaft Sleeve, EPT seal               |
|                                    | 185359                             | MF 60 with 5 1/4" & 6 1/4" impellers  | Stn. Stl. Shaft Sleeve, Viton seal             |
|                                    | 185360                             | MF 60 with 7" impellers   | BF Const., Copper Shaft Sleeve, EPT seal       |
|                                    | 185361                             | MF 60 with 7" impellers   | BF Const., Copper Shaft Sleeve, Viton seal     |
|                                    | 185362                             | MF 60 with 7" impellers   | BF Const., Stn. Stl. Shaft Sleeve, Buna-N seal |

CF – contact factory for where used.

**NOTE:** Obs. = Obsolete Pump Model, MF = Maintenance Free

## “WHERE USED” LIST (CONTINUED)

| CATEGORY                       | PART NO.                      | WHERE USED   | NOTES/SPECIFICATION                               |
|--------------------------------|-------------------------------|--|---|
| BEARING ASSEMBLIES (CONTINUED) | 185363                        | MF 60 with 7" impellers  | BF Const., Stn. Stl. Shaft Sleeve, EPT seal       |
|                                | 185364                        | MF 60 with 7" impellers  | BF Const., Stn. Stl. Shaft Sleeve, Viton seal     |
|                                | 185365                        | MF 60 with 7" impellers  | AB Const., Copper Shaft Sleeve, EPT seal          |
|                                | 185366                        | MF 60 with 7" impellers  | AB Const., Copper Shaft Sleeve, Viton seal        |
|                                | 185367                        | MF 60 with 7" impellers  | AB Const., Stn. Stl. Shaft Sleeve, Buna-N seal    |
|                                | 185368                        | MF 60 with 7" impellers  | AB Const., Stn. Stl. Shaft Sleeve, EPT seal       |
|                                | 185369                        | MF 60 with 7" impellers  | AB Const., Stn. Stl. Shaft Sleeve, Viton seal     |
|                                | 186863                        | PD-35, PD-37, 60 "AA", 1522  | Bronze Fitted or All Bronze models                |
|                                | 186865                        | PD-35, PD-37, 60 "AA", 1522  | All Iron models only                              |
|                                | 189034                        | Series 100   | Bronze models only                                |
|                                | 189105                        | PR, 2 1/2", LD-3, HD-3   | Cast Iron or Bronze models                        |
|                                | 189134                        | Series 100   | Cast Iron models only, includes NFI impeller      |
|                                | 189161                        | Series 100   | Bronze models only, includes NFI Impeller         |
|                                | 189162                        | Obs. 1", Obs. 1 1/4", Obs. 1 1/2"  | Cast Iron or Bronze models                        |
|                                | 189163                        | Obs. 1 1/2", Obs. 2", Obs. HV  | Cast Iron models with Bronze impellers            |
|                                | 189165                        | HV, 2", Obs 1 1/2"   | Cast Iron or Bronze models                        |
|                                | 189166                        | HV, 2"   | Cast Iron or Bronze models, includes NFI Impeller |
| P10316                         | 1522                          | BFE models only, includes EPT seal   |   |
| BODY GASKETS                   | P04080                        | Series 100   |   |
|                                | P04890                        | HV, 2", Obs. 1", Obs. 1 1/4", Obs. 1 1/2", Obs. 2", Obs. HV  |   |
|                                | P05800                        | PR, 2 1/2", LD-3, HD-3   |   |
|                                | P15691                        | Obs. LR-20BF, Obs. LR-15B, Obs. LR-20B, Obs. LR-12BF, Obs. LR-12B, All Series PL Models except PL-55 and PL-55B              |   |
|                                | P57410                        | PD-35, PD-37, 60 "AA", 1522, MF 60 with 5 1/4" & 6 1/4" impellers  |   |
|                                | P57700                        | PD-38, PD-40, Obs. PD-39, 60 "A", MF 60 with 7" impellers  |   |
|                                | P57701                        | 60 2 1/2F  |   |
|                                | P83025                        | PL-55 and PL-55B   |   |
| BEARING BRACKETS               | P57282                        | PD-38, PD-40, Obs. PD-39, 60 "A", 60 2 1/2F  |   |
|                                | P77106                        | Obs. 1", Obs. 1 1/4", Obs. 1 1/2", Obs. 2", Obs. HV  |   |
|                                | P77119                        | Series 100   |   |
|                                | P77139                        | HV, 2", Obs. 1 1/2", Obs. HV   |   |
|                                | P77177                        | PR, 2 1/2", LD-3, HD-3   |   |
|                                | P77179                        | PD-35, PD-37, 60 "AA", 1522  |   |
|                                | P77198                        | Obs. 1522  | Stainless Steel models only                       |
| COVER-PLATES                   | P09421                        | Obs. 1522 models only  | Stainless Steel                                   |
|                                | P57242                        | 60 2 1/2F  | BF Construction                                   |
|                                | P57244                        | 60 2 1/2F  | AB Construction                                   |
|                                | P57246                        | PD-38, PD-40, Obs. PD-39, 60 "A"   |   |
|                                | P57248                        | PD-38, PD-40, Obs. PD-39, 60 "A"   | AB Construction                                   |
| WICK SETS                      | 118395                        | Series 100, HV, 2", PR, 2 1/2", LD-3, HD-3, PD-35, PD-37, 60 "AA", 1522, Obs. 1", Obs. 1 1/4", Obs. 1 1/2", Obs. 2", Obs. HV |   |
|                                | P04883                        | PD-38, PD-40, Obs. PD-39, 60 "A", 60 2 1/2F  | 2 required  |
| FRONT BEARINGS                 | 185241                        | PD-38, PD-40, Obs. PD-39, 60 "A", 60 2 1/2F  |   |
|                                | 189071                        | Series 100   |   |
|                                | P77087                        | PR, 2 1/2", LD-3, HD-3   |   |
|                                | P77215                        | PD-35, PD-37, 60 "AA", 1522  | All Iron models only                              |
|                                | P77216                        | PD-35, PD-37, 60 "AA", 1522  |   |
|                                | P77217                        | Obs. 1522  | Stainless Steel models only                       |
|                                | P77308                        | HV, 2", Obs. 1", Obs. 1 1/4", Obs. 1 1/2"  |   |
|                                | P77309                        | Obs. 2", Obs. HV   | Cast Iron models                                  |
| P77309                         | Obs. 1 1/2", Obs. 2", Obs. HV | Bronze models only   |   |

**NOTE:** Obs. = Obsolete Pump Model, MF = Maintenance Free



## “WHERE USED” LIST (CONTINUED)

| CATEGORY              | PART NO.  | WHERE USED  | NOTES/SPECIFICATION  |
|-----------------------|---|---|--|
| REAR BEARINGS         | 118697  | PD-35, PD-37, Obs. 60 “AA”, Obs. 1522   | For Obs. Replacement<br>Bearing Assembly Models:<br>118478, 118479, 118480 |
|                       | 185240  | PD-38, PD-40, Obs. PD-39, 60 “A”, 60 2 <sup>1</sup> / <sub>2</sub> F  |  |
| SEAL KITS             | 118680  | Series 100, HV, 2", PR, 2 <sup>1</sup> / <sub>2</sub> ", LD-3, HD-3, PD-35, PD-37, 60 “AA”, 1522, Obs. 1", Obs. 1 <sup>1</sup> / <sub>4</sub> ", Obs. 1 <sup>1</sup> / <sub>2</sub> ", Obs. 2", Obs. HV, MF 60 with 5 <sup>1</sup> / <sub>4</sub> " x 6 <sup>1</sup> / <sub>4</sub> " impellers | Seal less seat insert  |
|                       | 118681  | Series 100, HV, 2", PR, 2 <sup>1</sup> / <sub>2</sub> ", LD-3, HD-3, PD-35, PD-37, 60 “AA”, 1522, Obs. 1", Obs. 1 <sup>1</sup> / <sub>4</sub> ", Obs. 1 <sup>1</sup> / <sub>2</sub> ", Obs. 2", Obs. HV, MF 60 with 5 <sup>1</sup> / <sub>4</sub> " x 6 <sup>1</sup> / <sub>4</sub> " impellers |  |
|                       | 118682  | Series 100, HV, 2", PR, 2 <sup>1</sup> / <sub>2</sub> ", LD-3, HD-3, PD-35, PD-37, 60 “AA”, 1522, Obs. 1", Obs. 1 <sup>1</sup> / <sub>4</sub> ", Obs. 1 <sup>1</sup> / <sub>2</sub> ", Obs. 2", Obs. HV   | Seal less seat insert  |
|                       | 185222  | 100, HV, 2", PR, 2 <sup>1</sup> / <sub>2</sub> ", LD-3, HD-3, PD-35, PD-37, 60 “AA”, 1522, Obs. 1", Obs. 1 <sup>1</sup> / <sub>4</sub> ", Obs. 1 <sup>1</sup> / <sub>2</sub> ", Obs. 2", Obs. HV  | EPT Elastomer  |
|                       | 185223  | PD-38, PD-40, Obs. PD-39, 60 “A”, 60 2 <sup>1</sup> / <sub>2</sub> F, MF 60 with 7" impellers   | EPT Elastomer  |
|                       | 185224  | PD-38, PD-40, Obs. PD-39, 60 “A”, 60 2 <sup>1</sup> / <sub>2</sub> F  | EPT Elastomer  |
|                       | 185227  | All PD-38, PD-40, Obs. PD-39, 60 “A”, 60 2 <sup>1</sup> / <sub>2</sub> F  | Teflon Elastomer   |
|                       | 185230  | Series 100, HV, 2", PR, 2 <sup>1</sup> / <sub>2</sub> ", LD-3, HD-3, PD-35, PD-37, 60 “AA”, 1522, Obs. 1", Obs. 1 <sup>1</sup> / <sub>4</sub> ", Obs. 1 <sup>1</sup> / <sub>2</sub> ", Obs. 2", Obs. HV, MF 60 with 5 <sup>1</sup> / <sub>4</sub> " x 6 <sup>1</sup> / <sub>4</sub> " impellers | EPT Elastomer  |
|                       | 186433  | PD-38, PD-40, Obs. PD-39, 60 “A”, 60 2 <sup>1</sup> / <sub>2</sub> F  |  |
|                       | 186499  | PD-38, PD-40, Obs. PD-39, 60 “A”, 60 2 <sup>1</sup> / <sub>2</sub> F, MF 60 with 7" impellers   |  |
|                       | 186681  | Series 100, HV, 2", PR, 2 <sup>1</sup> / <sub>2</sub> ", LD-3, HD-3, PD-35, PD-37, 60 “AA”, 1522, Obs. 1", Obs. 1 <sup>1</sup> / <sub>4</sub> ", Obs. 1 <sup>1</sup> / <sub>2</sub> ", Obs. 2", Obs. HV   |  |
|                       | 186875  | Series 100, HV, 2", PR, 2 <sup>1</sup> / <sub>2</sub> ", LD-3, HD-3, PD-35, PD-37, 60 “AA”, 1522, Obs. 1", Obs. 1 <sup>1</sup> / <sub>4</sub> ", Obs. 1 <sup>1</sup> / <sub>2</sub> ", Obs. 2", Obs. HV, MF 60 with 5 <sup>1</sup> / <sub>4</sub> " x 6 <sup>1</sup> / <sub>4</sub> " impellers | Viton Elastomer  |
|                       | 189144  | PL-30, PL-36, PL-45, PL-50, PL-75   |  |
|                       | 189174  | PL-130  |  |
|                       | 189577  | PL-55   |  |
| P59861                | Series 100, HV, 2", PR, 2 <sup>1</sup> / <sub>2</sub> ", LD-3, HD-3, PD-35, PD-37, 60 “AA”, 1522, Obs. 1", Obs. 1 <sup>1</sup> / <sub>4</sub> ", Obs. 1 <sup>1</sup> / <sub>2</sub> ", Obs. 2", Obs. HV | Seal less seat insert   |  |
| SHAFTS & SLEEVES      | 118469  | PD-38, PD-40, Obs. PD-39, 60 “A”, 60 2 <sup>1</sup> / <sub>2</sub> F  |  |
|                       | 189035  | Series 100, HV, 2", PR, 2 <sup>1</sup> / <sub>2</sub> ", LD-3, HD-3, PD-35, PD-37, 60 “AA”, 1522, Obs. 1", Obs. 1 <sup>1</sup> / <sub>4</sub> ", Obs. 1 <sup>1</sup> / <sub>2</sub> ", Obs. 2", Obs. HV   |  |
|                       | P08725  | PD-38, PD-40, Obs. PD-39, 60 “A”  | All Iron models only   |
|                       | P81960  | PD-35, PD-37, 60 “AA”, 1522   | All Iron models only   |
| PUMP BODIES & VOLUTES | 118339  | Series 100  | Cast Iron  |
|                       | 118413  | Series 100  | Bronze   |
|                       | 118449  | PD-35, PD-37, MF 60 3 x 5 <sup>1</sup> / <sub>4</sub>   | Cast Iron  |
|                       | 118637  | PR  | Cast Iron  |
|                       | 118644  | 2 <sup>1</sup> / <sub>2</sub> ", LD-3, HD-3   | Cast Iron  |
|                       | 186074  | 1522 3/4AAB   | Cast Iron  |
|                       | 186075  | 1522 1AAB   | Cast Iron  |
|                       | 186081  | 1522 1 <sup>1</sup> / <sub>4</sub> AAB  | Cast Iron  |
|                       | 186087  | 1522 1 <sup>1</sup> / <sub>2</sub> AAB  | Cast Iron  |
|                       | 186333  | 1522 3/4AAB   | Bronze   |
|                       | 186334  | 1522 1 <sup>1</sup> / <sub>2</sub> AAB  | Bronze   |
|                       | 186384  | 60 1AA  | Cast Iron  |
|                       | 186385  | 60 1AA  | Bronze   |
|                       | 186386  | 60 1 <sup>1</sup> / <sub>4</sub> AA, MF 60 1 x 5 <sup>1</sup> / <sub>4</sub> , MF 60 1 <sup>1</sup> / <sub>4</sub> x 5 <sup>1</sup> / <sub>4</sub>  | Cast Iron  |
|                       | 186389  | 60 1 <sup>1</sup> / <sub>2</sub> A, MF 60 1 <sup>1</sup> / <sub>2</sub> x 5 <sup>1</sup> / <sub>4</sub> , MF 60 2 x 5 <sup>1</sup> / <sub>4</sub>   | Cast Iron  |
|                       | 186390  | 60 1 <sup>1</sup> / <sub>2</sub> A, MF 60 1 <sup>1</sup> / <sub>2</sub> x 7   | Bronze   |
|                       | 186392  | 60 2AA, MF 60 2 x 5 <sup>1</sup> / <sub>4</sub>   | Cast Iron  |
|                       | 186671  | MF 60 1 <sup>1</sup> / <sub>2</sub> x 6 <sup>1</sup> / <sub>4</sub>   | AB Construction  |
|                       | 186672  | MF 60 2 x 6 <sup>1</sup> / <sub>4</sub>   | AB Construction  |
|                       | 186931  | 60 1 <sup>1</sup> / <sub>4</sub> AA, MF 60 1 x 5 <sup>1</sup> / <sub>4</sub> , MF 60 1 <sup>1</sup> / <sub>4</sub> x 5 <sup>1</sup> / <sub>4</sub>  | AB Construction  |
|                       | 186932  | 60 1 <sup>1</sup> / <sub>2</sub> AA, MF 60 1 <sup>1</sup> / <sub>2</sub> x 5 <sup>1</sup> / <sub>4</sub>  | AB Construction  |
|                       | 186933  | 60 2AA, MF 60 2 x 5 <sup>1</sup> / <sub>4</sub>   | AB Construction  |
|                       | 186934  | 60 1 <sup>1</sup> / <sub>2</sub> A, MF 60 1 <sup>1</sup> / <sub>2</sub> x 7   | AB Construction  |
|                       | 186935  | MF 60 1 <sup>1</sup> / <sub>2</sub> x 6 <sup>1</sup> / <sub>4</sub>   | BF Construction  |
|                       | 186936  | MF 60 2 x 6 <sup>1</sup> / <sub>4</sub>   | BF Construction  |
|                       | 186937  | 60 2A, MF 60 2 x 7  | BF Construction  |
|                       | 186938  | 60 2A, MF 60 2 x 7  | AB Construction  |

**NOTE:** Obs. = Obsolete Pump Model, MF = Maintenance Free

## “WHERE USED” LIST (CONTINUED)

| CATEGORY                             | PART NO.   | WHERE USED   | NOTES/SPECIFICATION  |
|--------------------------------------|--|--|--|
| PUMP BODIES & VOLUTES<br>(CONTINUED) | 189124   | HV   | Cast Iron  |
|                                      | 189125   | HV   | Bronze   |
|                                      | 189126   | 2"   | Cast Iron  |
|                                      | 189127   | 2"   | Bronze   |
|                                      | P00240   | PR   | Bronze   |
|                                      | P07610   | 2 1/2", LD-3, HD-3   | Bronze   |
|                                      | P08440   | PD-38, PD-40, Obs. PD-39   | Bronze   |
|                                      | P08460   | PD-38, PD-40, Obs. PD-39   | Cast Iron  |
|                                      | P09290   | PD-35, PD-37, MF 60 3 x 5 1/4  | Bronze   |
|                                      | P41160   | Obs. 1522 1AAB   | Bronze   |
|                                      | P41300   | Obs. 1522 1 1/4AAB   | Bronze   |
|                                      | P57232   | Series 60 2 1/2F   | BF Construction  |
|                                      | P57234   | Series 60 2 1/2F   | AB Construction  |
| BODY OR VOLUTE<br>CAPSCREWS          | P00660   | Obs. 1522  | Stainless Steel models only, 8 required  |
|                                      | P01850   | 60 "AA", 1522, MF 60 with 5 1/4" impeller  | All Bronze models only, 8 required   |
|                                      | P03470   | HV, 2", PR, 2 1/2", LD-3, HD-3, 60 2 1/2F, Obs. 1", Obs. 1 1/4", Obs. 1 1/2", Obs. HV, Obs. 2"                 | 60 2 1/2F Bronze Fitted only, 12 required all other circulators, 4 required                                    |
|                                      | P10620   | PD-35, PD-37, 60 "AA", 1522, MF 60 with 5 1/4" and 6 1/4" impellers  | For all Cast Iron and All Iron models  |
|                                      | P40020   | Series 100, PD-38, PD-40, Obs. PD-39, MF 60 with 7" impeller, 60 "A"   | For all Series 100 models, 4 required. For all Bronze Fitted or All Iron PD, 60 "A" or 1522 models, 8 required |
|                                      | P52310   | 60 "A", MF 60 with 7" impeller   | All Bronze models only   |
| S04180                               | 60 2 1/2F  | All Bronze models only   |  |
| VOLUTE DRAIN<br>PLUGS                | P39020   | 60 "AA", 60 "A", 1522, All MF 60   | All Cast Iron or All Iron models, 5 required for Series 60, 4 required for 1522                                |
|                                      | P39030   | Obs. 1522  | Stainless Steel models only, 4 required  |
|                                      | P39040   | 60 2 1/2F  | Bronze Fitted models only, 5 required  |
|                                      | P39470   | 60 "AA", 60 "A", 1522, All MF 60   | All Bronze models only, 5 required for Series 60, 4 required for 1522  |
|                                      | P39480   | 60 2 1/2F  | All Bronze models only, 5 required   |
| IMPELLERS                            | 118431   | Series 100   | Brass – 2 3/4" Diameter  |
|                                      | 118434   | Obs. 1"  | Brass – 3 1/16" Diameter   |
|                                      | 118435   | Obs. 1 1/4", Obs. 1 1/2"   | Brass – 3 5/16" Diameter   |
|                                      | 118436   | Obs. HV, Obs. 2", Obs. 1 1/4", Obs. 1 1/2"   | Brass – 3 3/8" Diameter  |
|                                      | 118439   | HD-3   | Brass – 4 1/4" Diameter  |
|                                      | 118440   | 2 1/2", LD-3   | Brass – 3 7/8" Diameter  |
|                                      | 118452   | PD-40, Obs. PD-39  | Cast Iron – 6" Diameter  |
|                                      | 118453   | PD-40, Obs. PD-39  | Brass – 6" Diameter  |
|                                      | 118612   | PR   | Brass – 4 1/4" Diameter  |
|                                      | 118626   | PD-37, Obs. 60-14S, Obs. 60-14T, Obs. 60-B14S, Obs. 60-B14T, Obs. 60-4S, Obs. 60-4T, 1522 4S, 1522 4T          | Brass – 5 1/4" Diameter  |
|                                      | 118627   | PD-35  | Brass – 4 3/4" Diameter  |
|                                      | 118629   | PD-37  | Steel – 5 1/4" Diameter  |
|                                      | 118630   | PD-35  | Steel – 4 3/4" Diameter  |
|                                      | 118665   | Obs. 1"  | Steel – 3 1/2" Diameter  |
|                                      | 118666   | Obs. 1 1/4", Obs. 1 1/2"   | Steel – 3 5/16" Diameter   |
|                                      | 118668   | Obs. HV, Obs. 2"   | Steel – 3 3/8" Diameter  |
|                                      | 118675   | HD-3   | Steel – 4 1/4" Diameter  |
|                                      | 118676   | 2 1/2", LD-3   | Steel – 3 7/8" Diameter  |
|                                      | 118830   | PR   | Steel – 4 1/4" Diameter  |
|                                      | 186359   | Obs. 60-10S, Obs. 60-1S, Obs. 60-1T, Obs. 60-2S, Obs. 60-2T, 1522 1S, 1522 1T, 1522 2S, 1522 2T, Obs. 1522 15T | Bronze – 5 1/4" Diameter   |
| 186360                               | Obs. 60-11S, Obs. 60-11T, Obs. 60-B11S, Obs. 1522 9S, Obs. 1522 9T | Bronze – 5 3/16" Diameter  |  |
| 186361                               | Obs. 1522 12S, Obs. 1522 12T                                       | Bronze – 4 1 1/16" Diameter  |  |
| 186362                               | Obs. 1522 7S, Obs. 1522 7T   | Bronze – 4 3/8" Diameter   |  |
| 186363                               | Obs. 1522 5S, Obs. 1522 5T   | Bronze – 4" Diameter   |  |

**NOTE:** Obs. = Obsolete Pump Model, MF = Maintenance Free

## “WHERE USED” LIST (CONTINUED)

| CATEGORY              | PART NO. | WHERE USED   | NOTES/SPECIFICATION        |
|-----------------------|----------|--|----------------------------|
| IMPELLERS (CONTINUED) | 186364   | Obs. 1522 14S, Obs. 1522 14T   | Bronze – 37/16" Diameter   |
|                       | 186366   | Obs. 1522 6S, Obs. 1522 6T   | Bronze – 37/8" Diameter    |
|                       | 186368   | Obs. 60-13S, Obs. 60-13T, Obs. 60-B13S, Obs. 60-B13T, Obs. 60-3S, Obs. 60-3T, 1522 3S, 1522 3T             | Bronze – 51/4" Diameter    |
|                       | 186370   | Obs. 1522 16S, Obs. 1522 16T   | Bronze – 41/8" Diameter    |
|                       | 186371   | Obs. 1522 8S, Obs. 1522 8T   | Bronze – 35/8" Diameter    |
|                       | 186373   | Obs. 1522 11T  | Bronze – 315/16" Diameter  |
|                       | 186375   | Obs. 1522 17S, Obs. 1522 17T   | Bronze – 311/16" Diameter  |
|                       | 189128   | HV, 2"   | NFI – 33/8" Diameter       |
|                       | 189132   | Series 100   | NFI – 23/4" Diameter       |
|                       | 189169   | PL-50, PL-50B, PL-75, PL-75B   | NFI – 2" Diameter          |
|                       | 189170   | PL-30, PL-30B, PL-36, PL-36B   | NFI – 31/16" Diameter      |
|                       | 189171   | PL-45, PL-45B  | NFI – 23/4" Diameter       |
|                       | 189172   | PL-55, PL-55B  |                            |
|                       | 189173   | PL-130, PL-130B  |                            |
|                       | P07792   | HV, 2"   | Bronze – 33/8" Diameter    |
|                       | P08690   | PD-38  | Bronze – 53/4" Diameter    |
|                       | P08709   | PD-38  | Cast Iron – 53/4" Diameter |
|                       | P15627   | Obs. LR-20BF, Obs. LR-15B, Obs. LR-20B   | NFI – 21/4" Diameter       |
|                       | P15629   | Obs. LR-12BF, Obs. LR-12B  | NFI – 21/2" Diameter       |
|                       | P56550   | 60 1AA, 60 11/4AA, 1522 3/4AAB, 1522 1AAB  | Bronze – 51/4" Diameter    |
|                       | P56740   | 60 11/2AA, 1522 11/4AAB  | Bronze – 51/4" Diameter    |
|                       | P56810   | 1522 11/2AAB, 60 2AA   | Bronze – 51/4" Diameter    |
|                       | P57440   | MF 60 11/2 x 7, 60-618T  | Bronze – 7" Diameter       |
|                       | P57445   | Obs. 60-17S, Obs. 60-17T, 60 11/2A, Obs. 60-6S, Obs. 60-6T, Obs. 60-7S, Obs. 60-7T                         | Bronze – 7" Diameter       |
|                       | P57446   | Obs. 60-16S, Obs. 60-16T   | Bronze – 63/8" Diameter    |
|                       | P57447   | Obs. 60-15S, Obs. 15T, Obs. 60-5S, Obs. 60-5T  | Bronze – 53/4" Diameter    |
|                       | P57450   | Obs. 60-21T, 60 2A, Obs. 60-10T  | Bronze – 63/4" Diameter    |
|                       | P57451   | Obs. 60-20S, Obs. 60-20T, Obs. 60-9S, Obs. 60-9T   | Bronze – 61/8" Diameter    |
|                       | P57452   | Obs. 60-19S, Obs. 60-19T, Obs. 60-8S, Obs. 60-8T   | Bronze – 55/8" Diameter    |
|                       | P57460   | 60-617S, 60-617T   | Bronze – 61/2" Diameter    |
|                       | P57500   | 60 11/2A   | Cast Iron – 7" Diameter    |
|                       | P57580   | MF 60 2 x 7, 60-620T   | Bronze – 7" Diameter       |
|                       | P57583   | 60 21/2F   | Bronze – 8" Diameter       |
|                       | P57584   | Obs. 60-22T  | Bronze – 73/4" Diameter    |
|                       | P58536   | MF 60 2 x 51/4 and 3 x 51/4, 60-627S, 60-627T, 60-B627S, 60-B627T  |                            |
|                       | P58538   | MF 60 11/2 x 51/4, 60-609S, 60-609T, 60-B609S, 60-B609T  |                            |
|                       | P58541   | MF 60 1 x 51/4 and 11/4 x 51/4, 60-603S, 60-603T, 60-B603S, 60-B603T, 60-606S, 60-606T, 60-B606S, 60-B606T |                            |
|                       | P58562   | MF 60 2 x 61/4, 60-616S, 60-616T   |                            |
|                       | P58564   | MF 60 11/2 x 61/4, 60-614S, 60-614T, 60-B614S, 60-B614T  |                            |
|                       | P58661   | 60-621S, 60-621T, 60-B621S, 60-B621T   |                            |
|                       | P58662   | 60-622S, 60-622T   | Bronze – 51/2" Diameter    |
|                       | P58663   | 60-623S, 60-623T   | Bronze – 6" Diameter       |
|                       | P58664   | 60-624S, 60-624T   |                            |
|                       | P58665   | 60-625S, 60-625T   | Bronze – 61/8" Diameter    |
|                       | P60350   | 60 1AA, 60 11/4AA, 1522 3/4AAB, 1522 1AAB  | Steel – 51/4" Diameter     |
|                       | P61010   | 60 11/2AA, 1522 11/4AAB  | Steel – 51/4" Diameter     |
|                       | P61550   | 60 2AA, 1522 11/2AAB   | Steel – 51/4" Diameter     |
|                       | P82137   | 60-619T  | Bronze – 61/2" Diameter    |
|                       | P82877   | 60-602S, 60-602T, 60-B602S, 60-B602T, 60-605S, 60-605T, 60-B605S, 60-B605T                                 | Bronze – 53/4" Diameter    |
|                       | P82878   | 60-601S, 60-601T, 60-B601S, 60-B601T, 60-604S, 60-604T, 60-B604S, 60-B604T                                 | Bronze – 43/8" Diameter    |
|                       | P82880   | 60-608S, 60-608T, 60-B608S, 60-B608T   | Bronze – 415/16" Diameter  |
|                       | P82881   | 60-607S, 60-607T, 60-B607S, 60-B607T   | Bronze – 43/8" Diameter    |
|                       | P82882   | 60-611S, 60-611T, 60-B611S, 60-B611T   | Bronze – 43/4" Diameter    |
|                       | P82883   | 60-610S, 60-610T, 60-B610S, 60-B610T   | Bronze – 41/8" Diameter    |
|                       | P82884   | 60-613S, 60-613T   |                            |
|                       | P82885   | 60-615S, 60-615T, 60-B615S, 60-B615T   |                            |
|                       | P83023   | 60-626S, 60-626T, 60-B626S, 60-B626T   |                            |

CF – contact factory for where used.

**NOTE:** Obs. = Obsolete Pump Model, MF = Maintenance Free

## “WHERE USED” LIST (CONTINUED)

| CATEGORY           | PART NO.  | WHERE USED  | NOTES/SPECIFICATION                              |
|--------------------|---|---|--|
| FLANGES            | A24600  | PD-38, PD-40, Obs. PD-39  | Steel – 3"                                       |
|                    | A40000  | PD-38, PD-40, Obs. PD-39  | Brass – 3"                                       |
|                    | F14200  | 2", Obs. 2", 60 2AA, 60 2A, PL-75, PL-130, MF 60 2"   | Steel – 2"                                       |
|                    | F54200  | 2", Obs. 2", 60-B14S, 60-B14T, 60 2AA, 60 2A, PL-75B, PL-130B, MF 60 2"   | Bronze – 2"                                      |
|                    | F74000  | LD-3, HD-3, PD-35, PD-37, PL-130, MF 60 3 x 5 1/4   | Steel – 3"                                       |
|                    | F74800  | LD-3, HD-3, PD-35, PD-37, PL-130B, MF 60 3 x 5 1/4  | Brass – 3"                                       |
|                    | P00739  | PL-30, PL-36, PL-55, Obs. LR-250BF, Obs. LR-12, Obs. LR-12BF, Series 100, PR  | Steel – 3/4"                                     |
|                    | P00779  | PL-30B, PL-36B, Series 100, LR, PR, PL-55B  | Brass – 1 1/2"                                   |
|                    | P00789  | PL-30B, PL-36B, PL-55B, LR, Series 100, PR  | Brass – 3/4"                                     |
|                    | P00792  | PL-30, PL-36, Series 100, Obs. LR, PR, 60 1AA, PL-55  | Steel – 1"                                       |
|                    | P00802  | PL-45, PL-50, HV, Obs. HV   | Steel – 1"                                       |
|                    | P00804  | PL-45B, PL-50B, HV, Obs. 1", Obs. HV  | Brass – 1"                                       |
|                    | P00836  | LR-20B, LR-12B, LR-15B, PL-30B, PL-36B, Series 100, PR, PL-55B  | Brass – 1"                                       |
|                    | P00837  | LR-20B, LR-12B, LR-15B, PL-30B, PL-36B, Series 100, PR, PL-55B  | Brass – 1 1/4"                                   |
|                    | P01510  | MF 60 1 x 5 1/4, 60 1"AA  |  |
|                    | P03250  | PL-30, PL-36, PL-55, Series 100, Obs. LR, PR, Obs. 1 1/4", 60 1 1/4AA, MF60 1 1/4 x 5 1/4                           | Steel – 1 1/4"                                   |
|                    | P03300  | PL-45, PL-50, HV, Obs. HV   | Steel – 1 1/4"                                   |
|                    | P03410  | PL-45, PL-50, HV, Obs. 1 1/2", Obs. HV, 60 1 1/2AA, 60 1 1/2A, MF 60 1 1/2"   | Steel – 1 1/2"                                   |
|                    | P03430  | PL-30, PL-36, Series 100, Obs. LR, PR, PL-55  | Steel – 1 1/2"                                   |
|                    | P03560  | 2 1/2", PL-130  | Steel – 2 1/2"                                   |
| P06660             | PL-45B, PL-50B, HV, Obs. 1 1/4", Obs. HV                                      | Brass – 1 1/4"  |  |
| P06690             | PL-45B, PL-50B, HV, Obs. 1 1/2", Obs. HV, 60 1 1/2AA, 60 1 1/2A, MF 60 1 1/2" | Brass – 1 1/2"  |  |
| P06750             | 2 1/2", PL-130B   | Brass – 2 1/2"  |  |
| FLANGE GASKET SETS | 118060  | Obs. HV, Obs. 1 1/4"  |  |
|                    | 118062  | Obs. 1 1/2"   |  |
|                    | 118065  | Obs. 2"   |  |
|                    | 118129  | 2 1/2", LD-3, HD-3, PD-35, PD-37, PD-38, PD-40, Obs. PD-39, MF 60 3 x 5 1/4, PL-130                                 |  |
|                    | 118351  | Obs. Series 100, Obs. 1"  |  |
|                    | 118368  | Obs. LR, PL-30, PL-36, Series 100, PR, 60 1AA, 60 1 1/4AA, PL-55, Obs. 1 1/4", MF 60 1 x 5 1/4, MF 60 1 1/4 x 5 1/4 |  |
|                    | 118373  | PL-45, PL-50, HV, Obs. 1 1/2", Obs. HV, 60 1 1/2AA, 60 1 1/2A, MF 60 1 1/2"   |  |
|                    | 118378  | 2", 60 2AA, 60 2A, MF 60 2", PL-75, PL-130  |  |
| P15692             | Obs. LR   | Not a set, 2 required   |  |
| FASTENER PACKS     | F91600  | Obs. 2"   |  |
|                    | P09540  | PD-38, PD-40, Obs. PD-39, PL-130  |  |
|                    | P15696  | Obs. LR   |  |
|                    | P64230  | Obs. 1"   |  |
|                    | P64900  | 60 1AA, 60 1 1/4AA  |  |
|                    | P64910  | Obs. LR, PL-30, PL-36, Series 100, 60 1AA, 60 1 1/4AA, Obs. 1 1/4", MF 60 1 x 5 1/4 and 1 1/4 x 5 1/4               |  |
|                    | P64930  | 60 1 1/2AA, 60 1 1/2A Obs. 1 1/2", Obs. HV, MF 60 1 1/2"  | Series 60 All Bronze models only                 |
|                    | P64940  | PL-45, PL-50, HV, 60 1 1/2AA, 60 1 1/2A, Obs. HV, Obs. 1 1/2", MF 60 1 1/2"   | Series 60 Bronze Fitted and All Iron models only |
|                    | P65030  | 2", 60 2AA, 60 2A, MF 60 2"   | Series 60 Bronze Fitted and All Iron models only |
|                    | P65031  | PL-75, PL-130, 2", MF 60 2", 60 2AA, 60 2A  |  |
|                    | P65128  | PR  |  |
| P65130             | 2 1/2", LD-3, HD-3, PD-35, PD-37, MF 60 3 x 5 1/4                             | Does not include flange gaskets   |  |
| P83031             | PL-55, PL-55B   |   |  |

CF – contact factory for where used.

**NOTE:** Obs. = Obsolete Pump Model, MF = Maintenance Free

## “WHERE USED” LIST (CONTINUED)

| CATEGORY                        | PART NO.             | PART DESCRIPTION  | WHERE USED   | NOTES/SPECIFICATION         |
|---------------------------------|----------------------|---|--|-----------------------------|
| <b>MISCELLANEOUS PUMP PARTS</b> | H32400               | Coupler Key   | PD-38, PD-40, Obs. PD-39, 60 "A", 60 2 <sup>1</sup> / <sub>2</sub> F   |                             |
|                                 | J91702               | Impeller Nut  | Obs. HV  | Cast Iron models only       |
|                                 | M15784               | Capacitor   | Obs. LR  | 220V                        |
|                                 | M15788               | Capacitor   | Obs. LR-15B  | 220V                        |
|                                 | P00651               | Impeller Nut  | Obs. 1522  | Stainless Steel models      |
|                                 | P04650               | Impeller Lockwasher   | 60 AA, 1522  |                             |
|                                 | P04660               | Impeller Washer   | Obs. 1522, MF 60 5 <sup>1</sup> / <sub>4</sub> " and 6 <sup>1</sup> / <sub>4</sub> "   |                             |
|                                 | P04670               | Impeller Nut  | PD-35, PD-37, 60 AA, 1522  | AI Construction             |
|                                 | P04940               | Impeller Key  | Series 100, HV, 2", PR, 2 <sup>1</sup> / <sub>2</sub> ", LD-3, HD-3, PD-35, PD-37, 60 "AA", 1522, Obs. 1", Obs. 1 <sup>1</sup> / <sub>4</sub> ", Obs. 1 <sup>1</sup> / <sub>2</sub> ", Obs. 2", Obs. HV, MF 60 5 <sup>1</sup> / <sub>4</sub> " and 6 <sup>1</sup> / <sub>4</sub> " |                             |
|                                 | P04945               | Impeller Key  | Obs. 1522  | Stainless Steel models only |
|                                 | P08480               | Impeller Nut  | PD-38, PD-40, Obs. PD-39, 60 "A", 60 2 <sup>1</sup> / <sub>2</sub> F, MF 60 7"   | All Bronze model only       |
|                                 | P11150               | Impeller Washer   | 60 2 <sup>1</sup> / <sub>2</sub> F, PD-38, PD-40, Obs. PD-39, 60 A   |                             |
|                                 | P11220               | Impeller Washer   | PD-38, PD-40, Obs. PD-39, MF 60 7", 60 A, 60 2 <sup>1</sup> / <sub>2</sub> F   | AB Construction             |
|                                 | P12422               | Oil Wick Retainer   | PD-38, PD-40, Obs. PD-39, 60 "A", 60 2 <sup>1</sup> / <sub>2</sub> F   |                             |
|                                 | P15210               | Assembly Tool   | Obs. LR  |                             |
|                                 | P15683               | Seat Cup  | Obs. LR  |                             |
|                                 | P15697               | Impeller Nut  | Obs. LR  |                             |
|                                 | P15698               | Impeller Tube   | Obs. LR  |                             |
|                                 | P15775               | Oil Tube  | Obs. LR  |                             |
|                                 | P44200               | Impeller Nut  | Series 100, HV, 2", PR, 2 <sup>1</sup> / <sub>2</sub> ", LD-3, HD-3, PD-35, PD-37, 60 "AA", 1522, Obs. 1", Obs. 1 <sup>1</sup> / <sub>4</sub> ", Obs. 1 <sup>1</sup> / <sub>2</sub> ", Obs. 2", Obs. HV, MF 60 5 <sup>1</sup> / <sub>4</sub> " and 6 <sup>1</sup> / <sub>4</sub> " |                             |
|                                 | P45910               | Impeller Nut  | PD-38, PD-40, Obs. PD-39, 60 "A", 60 2 <sup>1</sup> / <sub>2</sub> F   | Cast Iron Models Only       |
|                                 | P49358               | Impeller Key  | 60 "A", 2 <sup>1</sup> / <sub>2</sub> F, PD-38, PD-40, Obs. PD-39, MF 60 7"  |                             |
|                                 | P51190               | Flat head Capscrew  | Obs. 1522  |                             |
|                                 | P57000               | Impeller Gasket   | Series 100, HV, 2", PR, 2 <sup>1</sup> / <sub>2</sub> ", LD-3, HD-3, PD-35, PD-37, 60 "AA", 1522, Obs. 1 <sup>1</sup> / <sub>2</sub> ", Obs. 2", Obs. HV, Obs. 1", Obs. 1 <sup>1</sup> / <sub>4</sub> "  |                             |
|                                 | P57300               | Oil Well Gasket   | PD-38, PD-40, Obs. PD-39, 60 "A", 60 2 <sup>1</sup> / <sub>2</sub> F   |                             |
|                                 | P57302               | Oil Well Cover  | PD-38, PD-40, Obs. PD-39, 60 "A", 60 2 <sup>1</sup> / <sub>2</sub> F   |                             |
|                                 | P70712               | Ceramic Insert  | Obs. LR  |                             |
|                                 | P80815               | Front Bearing Gasket  | Series 100   |                             |
| P80816                          | Front Bearing Gasket | HV, 2", Obs. 1", Obs. 1 <sup>1</sup> / <sub>4</sub> ", Obs. 1 <sup>1</sup> / <sub>2</sub> ", Obs. 2", Obs. HV, PR, 2 <sup>1</sup> / <sub>2</sub> ", LD-3, HD-3, PD-35, PD-37, 60 "AA", 1522 |  |                             |
| P81238                          | Oil Well Cover       | Series 100  |  |                             |
| P81239                          | Oil Well Cover       | HV, 2", PR, 2 <sup>1</sup> / <sub>2</sub> ", LD-3, HD-3, PD-35, PD-37, 60 "AA", 1522, Obs. 1", Obs. 1 <sup>1</sup> / <sub>4</sub> ", Obs. 1 <sup>1</sup> / <sub>2</sub> ", Obs. 2", Obs. HV |  |                             |

**NOTE:** Obs. = Obsolete Pump Model

# “WHERE USED” LIST

| CATEGORY        | PART NO.                   | WHERE USED   | NOTES/SPECIFICATION |
|-----------------|----------------------------|--|---------------------|
| <b>BAFFLES</b>  | A03720                     | EAS-1 <sup>1</sup> / <sub>2</sub> , EAS-2  |                     |
|                 | A03835                     | EAS-1, EAS-1 <sup>1</sup> / <sub>4</sub>   |                     |
|                 | A07029                     | SDG-2 <sup>1</sup> / <sub>2</sub> , CC-3Z, DC-3Z, EC-3Z  | Stainless Steel     |
|                 | A07030                     | SDG-3, DD-3Z, ED-3Z  | Stainless Steel     |
|                 | A07031                     | SDG-4, EE-3Z, FE-3Z, GE-3Z   | Stainless Steel     |
|                 | A07032                     | SDG-5, FF-3Z, GF-3Z  | Stainless Steel     |
|                 | A07033                     | SDG-6, GG-3Z, HG-3Z  | Stainless Steel     |
|                 | A07034                     | SDG-8, HH-3Z, JH-3Z  | Stainless Steel     |
|                 | A07035                     | SDG-10, JJ-3Z  | Stainless Steel     |
|                 | A91554                     | Obs. DB, BA-3X   | Steel               |
|                 | A91555                     | BB-3X, CB-3X, DA-3X, DB-3X   | Steel               |
|                 | A91556                     | CC-3X, DC-3X, EC-3X  | Steel               |
|                 | A91557                     | DD-3X, ED-3X   | Steel               |
|                 | A91558                     | EE-3X, FE-3X, GE-3X  | Steel               |
|                 | A91559                     | FF-3X, GF-3X   | Steel               |
|                 | A91560                     | GG-3X, HG-3X   | Steel               |
|                 | A91561                     | HH-3X, JH-3X   | Steel               |
|                 | A91562                     | JJ-3X  | Steel               |
| A91563          | Obs. DB, BA-3Z             | Stainless Steel  |                     |
| A91564          | BB-3Z, CB-3Z, DA-3Z, DB-3Z | Stainless Steel  |                     |
| <b>BLADDERS</b> | 189579                     | B-200  |                     |
|                 | 189580                     | B-300  |                     |
|                 | 189581                     | B-400  |                     |
|                 | 189582                     | B-500  |                     |
|                 | 189583                     | B-600  |                     |
|                 | 189584                     | B-800  |                     |
|                 | 189585                     | B-1000   |                     |
|                 | 189586                     | B-1200   |                     |
|                 | 189587                     | B-1400   |                     |
|                 | 189588                     | B-1600   |                     |
|                 | 189589                     | B-2000   |                     |
|                 | 189590                     | B-2500   |                     |
|                 | 189591                     | B-3000   |                     |
|                 | 189592                     | B-3500   |                     |
|                 | 189593                     | B-4000   |                     |
|                 | 189594                     | B-35 LA, B-50 LA, B-85 LA, B-100 LA  |                     |
|                 | 189595                     | B-130 LA, B-165 LA, B-200 LA, B-300 LA   |                     |
|                 | 189596                     | B-400 LA, B-500 LA, B-600 LA   |                     |
| 189597          | B-5000                     |  |                     |
| <b>BODIES</b>   | A03715                     | EAS-1  |                     |
|                 | A03716                     | EAS-1 <sup>1</sup> / <sub>4</sub>  |                     |
|                 | A03831                     | EAS-1 <sup>1</sup> / <sub>2</sub>  |                     |
|                 | A03832                     | EAS-2  |                     |
|                 | G92500                     | TFI-1 <sup>1</sup> / <sub>4</sub> , TFI-1 <sup>1</sup> / <sub>2</sub> , TFI-2, TFI-2 <sup>1</sup> / <sub>2</sub> , TFI-3, TFI-4, TFI-5, TFI-6, TFI-8 |                     |
|                 | V01103                     | CTS-7524   |                     |
|                 | V18802                     | CB-4G, 3DS-4G  |                     |
|                 | V50807                     | 3DX-1  |                     |
|                 | V50808                     | 3DX-1 <sup>1</sup> / <sub>4</sub>  |                     |
|                 | V50809                     | 3DX-1 <sup>1</sup> / <sub>2</sub>  |                     |
|                 | V50810                     | 3D-2S  |                     |
|                 | V50811                     | 3D-2 <sup>1</sup> / <sub>2</sub> S   |                     |
|                 | V50812                     | 3D-3S  |                     |
|                 | V50813                     | 3D-4S  |                     |
|                 | V50814                     | 3D-5S  |                     |
|                 | V50815                     | 3D-6S  |                     |
|                 | V50816                     | 3D-8S  |                     |
|                 | V50817                     | 3D-10S   |                     |
|                 | V50818                     | 3DS-2G   |                     |
|                 | V50819                     | 3DS-2 <sup>1</sup> / <sub>2</sub> G  |                     |
|                 | V50820                     | 3DS-3G   |                     |
|                 | V50821                     | CB-5G, 3DS-5G  |                     |
|                 | V50822                     | CB-6G, 3DS-6G  |                     |
|                 | V50823                     | CB-8G, 3DS-8G  |                     |
|                 | V50824                     | CB-10G, 3DS-10G  |                     |
|                 | V50825                     | CB-12G, 3DS-10G  |                     |
|                 | V50830                     | 3DS-2S   |                     |
|                 | V50831                     | 3DS-2 <sup>1</sup> / <sub>2</sub> S  |                     |
|                 | V50832                     | 3DS-3S   |                     |
|                 | V50833                     | CB-4F, 3DS-4S  |                     |
| V50834          | CB-5F, 3DS-5S              |  |                     |

**NOTE:** Obs. = Obsolete Model

## “WHERE USED” LIST (CONTINUED)

| CATEGORY    | PART NO.     | WHERE USED  | NOTES/SPECIFICATION |
|-------------|--------------|---|---------------------|
| BODIES      | V50835       | CB-6F, 3DS-6S   |                     |
|             | V50836       | CB-8F, 3DS-8S   |                     |
|             | V50837       | CB-10F, 3DS-10S   |                     |
|             | V50838       | CB-12F, 3DS-12S   |                     |
|             | V50839       | 3DS-14S   |                     |
|             | V51958       | 3DS-3B  |                     |
|             | V51961       | 3DS-4B  |                     |
|             | V51964       | 3DS-5B  |                     |
|             | V51967       | 3DS-6B  |                     |
|             | V51970       | 3DS-8B  |                     |
|             | V51973       | 3DS-10B   |                     |
|             | V51976       | 3DS-12B   |                     |
|             | V51979       | 3DS-14B   |                     |
| V51982      | 3DS-16B      |   |                     |
| BONNETS     | G10001       | CB-4F   |                     |
|             | G10002       | CB-5F   |                     |
|             | G10003       | CB-6F   |                     |
|             | G10004       | CB-8F   |                     |
|             | G10060       | CB-4G   |                     |
|             | G10061       | CB-5G   |                     |
|             | G10062       | CB-6G   |                     |
|             | G10063       | CB-8G   |                     |
|             | V50986       | CB-10G  |                     |
|             | V50987       | CB-12F  |                     |
|             | V50988       | CB-12G  |                     |
|             | V51021       | CB-10F  |                     |
|             | V51122       | 3D-2S, 2DS-2S, 3D-2 <sup>1</sup> / <sub>2</sub> , 3DS-2 <sup>1</sup> / <sub>2</sub> S, 3DS-2S, 3DS-3B |                     |
|             | V51126       | 3D-3S, 3DS-3S, 3DS-4B   |                     |
|             | V51128       | 3D-4S, 3DS-4S, 3DS-5B   |                     |
|             | V51130       | 3D-5S, 3DS-5S, 3DS-6B   |                     |
|             | V51132       | 3D-6S, 3DS-6S, 3DS-8B   |                     |
|             | V51134       | 3D-8S, 3DS-8S, 3DS-10B  |                     |
|             | V51136       | 3D-10S, 3DS-10S, 3DS-12B  |                     |
|             | V51138       | 3DS-12S, 3DS-14B  |                     |
|             | V51140       | 3DS-14S, 3DS-16B  |                     |
|             | V51142       | 3DS-4G  |                     |
|             | V51811       | 3DS-2G, 2DS-2 <sup>1</sup> / <sub>2</sub> G   |                     |
|             | V51813       | 3DS-3G  |                     |
| V51815      | 3DS-5G       |   |                     |
| V51817      | 3DS-6G       |   |                     |
| V51819      | 3DS-8G       |   |                     |
| V51821      | 3DS-10G      |   |                     |
| V51841      | 3DS-12G      |   |                     |
| BUSH-INGS   | G10030       | CB-4F, CB-4G, CB-5F, CB-5G, CB-6F, CB-6G  |                     |
|             | G10038       | CB-8F, CB-8G  |                     |
|             | V51010       | CB-10F, CB-10G  |                     |
|             | V51011       | CB-12F, CB-12G  |                     |
| CAPS        | A03722       | EAS-1 <sup>1</sup> / <sub>2</sub> , EAS-2   |                     |
|             | A03834       | EAS-1, EAS-1 <sup>1</sup> / <sub>4</sub>  |                     |
|             | V50690       | 3DX-1   |                     |
|             | V50693       | 3DX-1 <sup>1</sup> / <sub>4</sub>   |                     |
|             | V50696       | 3DX-1 <sup>1</sup> / <sub>2</sub>   |                     |
| COVERPLATES | A07016       | SDG-2 <sup>1</sup> / <sub>2</sub>   |                     |
|             | A07018       | SDG-3   |                     |
|             | A07020       | SDG-4   |                     |
|             | A07022       | SDG-5   |                     |
|             | A07024       | SDG-6   |                     |
|             | A07026       | SDG-8   |                     |
|             | A07028       | SDG-10  |                     |
|             | A91242       | BA-3X, BA-3Z  |                     |
|             | A91244       | BB-3X, BB-3Z, CB-3X, CB-3Z, CC-3X, CC-3Z, DA-3X, DA-3Z, DB-3X, DB-3Z, DC-3X, DC-3Z                    |                     |
|             | A91246       | DD-3X, DD-3Z, ED-3X, ED-3Z  |                     |
|             | A91248       | EE-3X, EE-3Z, FE-3X, FE-3Z, GE-3X, GE-3Z  |                     |
|             | A91250       | FF-3X, FF-3Z, GF-3X, GF-3Z  |                     |
|             | A91252       | GG-3X, GG-3Z, HG-3X, HG-3Z  |                     |
|             | A91254       | HH-3X, HH-3Z, JH-3X, JH-3Z  |                     |
| A91256      | JJ-3X, JJ-3Z |   |                     |

## “WHERE USED” LIST (CONTINUED)

| CATEGORY             | PART NO. | WHERE USED  | NOTES/SPECIFICATION |
|----------------------|----------|---|---------------------|
| DATA PLATES          | V50855   | 3DX-1   |                     |
|                      | V50856   | 3DX-1 <sup>1</sup> / <sub>4</sub>   |                     |
|                      | V50857   | 3DX-1 <sup>1</sup> / <sub>2</sub>   |                     |
| DISCS                | G10009   | CB-4F, CB-4G  |                     |
|                      | G10010   | CB-5F, CB-5G  |                     |
|                      | G10011   | CB-6F, CB-6G  |                     |
|                      | G10012   | CB-8F, CB-8G  |                     |
|                      | V50697   | 3DX-1   |                     |
|                      | V50698   | 3DX-1 <sup>1</sup> / <sub>4</sub>   |                     |
|                      | V50699   | 3DX-1 <sup>1</sup> / <sub>2</sub>   |                     |
|                      | V50754   | 3DS-14S, 3DS-16B  |                     |
|                      | V50920   | 3DS-12S, 3DS-14B  |                     |
|                      | V50992   | CB-10F, CB-10G  |                     |
|                      | V50993   | CB-12F, CB-12G  |                     |
| V56884               | 3DS-12G  |   |                     |
| DISC ASSEMBLIES      | V51756   | 3DS-2G, 3D-2S, 3D-2 <sup>1</sup> / <sub>2</sub> S, 3DS-2S   |                     |
|                      | V51757   | 3DS-2 <sup>1</sup> / <sub>2</sub> G, 3DS-2 <sup>1</sup> / <sub>2</sub> S, 3DS-3B  |                     |
|                      | V51758   | 3DS-3G, 3D-3S, 3DS-3S, 3DS-4B   |                     |
|                      | V51759   | 3DS-4G, 3D-4S, 3DS-4S, 3DS-5B   |                     |
|                      | V51760   | 3DS-5G, 3D-5S, 3DS-5S, 3DS-6B   |                     |
|                      | V51761   | 3DS-6G, 3D-6S, 3DS-6S, 3DS-8B   |                     |
|                      | V51762   | 3DS-8G, 3D-8S, 3DS-8S, 3DS-10B  |                     |
|                      | V51763   | 3D-10S, 3DS-10S, 3DS-12B  |                     |
|                      | V51764   | 3DS-10G   |                     |
| DISC KITS            | 118858   | 3DX-1 <sup>1</sup> / <sub>4</sub>   |                     |
|                      | 118859   | 3DX-1 <sup>1</sup> / <sub>2</sub>   |                     |
|                      | 118860   | 3DX-1   |                     |
| DYNA DISC ASSEMBLIES | 118094   | SA-1 <sup>1</sup> / <sub>4</sub>  |                     |
|                      | 118095   | SA-1 <sup>1</sup> / <sub>2</sub> , SA-2   |                     |
|                      | 118096   | A-2 <sup>1</sup> / <sub>2</sub> , S-2 <sup>1</sup> / <sub>2</sub> , A-3, S-3  |                     |
|                      | 118117   | SA-1  |                     |
|                      | 118118   | S-4   |                     |
|                      | 118864   | SB- <sup>3</sup> / <sub>4</sub>   |                     |
|                      | 189168   | SA- <sup>3</sup> / <sub>4</sub>   |                     |
| FLANGE GASKETS       | F17400   | S-4   |                     |
|                      | F26200   | SA-2  |                     |
|                      | G82750   | A-2 <sup>1</sup> / <sub>2</sub> , S-2 <sup>1</sup> / <sub>2</sub>   |                     |
|                      | G86500   | A-3, S-3  |                     |
| GASKETS              | F19000   | S-4, 3D-3S, 3DS-3G, 3DS-3S, 3DS-4B  |                     |
|                      | F27800   | A-2 <sup>1</sup> / <sub>2</sub> , S-2 <sup>1</sup> / <sub>2</sub> , A-3, S-3, 3D-2S, 3DS-2G, 3DS-2S, 3D-2 <sup>1</sup> / <sub>2</sub> S, 3DS-2 <sup>1</sup> / <sub>2</sub> G, 3DS-2 <sup>1</sup> / <sub>2</sub> S, 3DS-3B |                     |
|                      | F43000   | SA- <sup>3</sup> / <sub>4</sub> , Obs. SA- <sup>3</sup> / <sub>4</sub> , Obs. SB- <sup>3</sup> / <sub>4</sub>   |                     |
|                      | F44400   | SA-1, 3DX-1   |                     |
|                      | F47200   | SA-1 <sup>1</sup> / <sub>4</sub> , 3DX-1 <sup>1</sup> / <sub>4</sub> , SA-1 <sup>1</sup> / <sub>2</sub> , SA-2  |                     |
|                      | F49000   | SA-1 <sup>1</sup> / <sub>2</sub> , SA-2, 3DX-1 <sup>1</sup> / <sub>2</sub>  |                     |
|                      | V29400   | CB-4F, CB-4G, 3D-4, 3DS-4G, 3DS-4S, 3DS-5B  |                     |
|                      | V32801   | 3D-5S, 3DS-5G, 3DS-5S, CB-5F, CB-5G, 3DS-6B   |                     |
|                      | V33001   | CB-6F, CB-6G, 3D-6S, 3DS-6G, 3DS-6S, 3DS-8B   |                     |
|                      | V35000   | CB-8F, CB-8G, 3D-8S, 3DS-8G, 3DS-8S, 3DS-10B  |                     |
|                      | V36400   | CB-10F, CB-10G, 3D-10S, 3DS-10G, 3DS-10S, 3DS-12B   |                     |
|                      | V36401   | CB-12F, CB-12G, 3DS-12G, 3DS-12S, 3DS-14B   |                     |
|                      | V36402   | 3DS-14S, 3DS-16B  |                     |
|                      | V56936   | SB- <sup>3</sup> / <sub>4</sub>   |                     |

**NOTE:** Obs. = Obsolete Model



## “WHERE USED” LIST (CONTINUED)

| CATEGORY                           | PART NO. | WHERE USED  | NOTES/SPECIFICATION |
|------------------------------------|----------|---|---------------------|
| GLAND WASHERS                      | G10032   | CB-4F, CB-4G, CB-5F, CB-5G, CB-6F, CB-6G  |                     |
|                                    | G10040   | CB-8F, CB-8G, CB-10F, CB-10G  |                     |
|                                    | V51003   | CB-12F, CB-12G  |                     |
| GLASS-TUBE KITS                    | 118098   | TB-3/4  |                     |
|                                    | 118820   | TFI-4, TFI-5, TFI-6, TFI-8  |                     |
|                                    | 118822   | TB-1  |                     |
|                                    | 189111   | TFI-1 <sup>1</sup> / <sub>4</sub> , TFI-1 <sup>1</sup> / <sub>2</sub> , TFI-2, TFI-2 <sup>1</sup> / <sub>2</sub> , TFI-3  |                     |
| HANDLES                            | F13400   | SA-3/4, SA-1, SA-1 <sup>1</sup> / <sub>4</sub> , SA-1 <sup>1</sup> / <sub>2</sub> , SB-3/4, SA-2, A-2 <sup>1</sup> / <sub>2</sub> , S-2 <sup>1</sup> / <sub>2</sub> , A-3, S-3,<br>Obs. SA-3/4, Obs. SB-3/4, 3DX-1, 3DX-1 <sup>1</sup> / <sub>4</sub> , 3DX-1 <sup>1</sup> / <sub>2</sub> |                     |
|                                    | F17800   | S-4   |                     |
| INDICATOR LOCKS OR INDICATOR STOPS | G10028   | CB-4F, CB-4G, CB-5F, CB-5G, CB-6F, CB-6G  | Indicator Lock      |
|                                    | G10036   | CB-8F, CB-8G, CB-10F, CB-10G  | Indicator Lock      |
|                                    | G96839   | CB-1 <sup>1</sup> / <sub>4</sub> , CB-1 <sup>1</sup> / <sub>4</sub> S, CB-1 <sup>1</sup> / <sub>2</sub> , CB-1 <sup>1</sup> / <sub>2</sub> S, CB-2, CB-2S, CB-2 <sup>1</sup> / <sub>2</sub> , CB-2 <sup>1</sup> / <sub>2</sub> F,<br>CB-3, CB-3F, CB-4                                    | Indicator Stop      |
|                                    | V51012   | CB-12F, CB-12G  | Indicator Lock      |
| INDICATOR RINGS                    | J94171   | 3DS-12G, 3DS-12S, 3DS-14S, 3DS-14B, 3DS-16B   |                     |
|                                    | V51180   | 3D-2S, 3DS-2G, 3DS-2S, 3D-2 <sup>1</sup> / <sub>2</sub> S, 3DS-2 <sup>1</sup> / <sub>2</sub> G, 3DS-2 <sup>1</sup> / <sub>2</sub> S, 3D-3S,<br>3DS-3G, 3DS-3S, 3DS-3B, 3DS-4B   |                     |
|                                    | V51181   | 3D-4S, 3DS-4G, 3DS-4S, 3D-5S, 3DS-5G, 3DS-5S, 3D-6S, 3DS-6G,<br>3DS-6S, 3D-8S, 3DS-8G, 3DS-8S, 3D-10S, 3DS-10G, 3DS-10S,<br>3DS-5B, 3DS-6B, 3DS-8B, 3DS-10B, 3DS-12B  |                     |
| KNOBS                              | G10105   | RF-1 <sup>2</sup> / <sub>S</sub> , RF-3 <sup>4</sup> / <sub>S</sub>   |                     |
|                                    | G95951   | CB-1 <sup>2</sup> / <sub>S</sub> , CB-1 <sup>2</sup> / <sub>S</sub> , CB-3 <sup>4</sup> / <sub>S</sub> , CB-3 <sup>4</sup> / <sub>S</sub> , CB-1, CB-1S   |                     |
|                                    | G96831   | CB-1 <sup>1</sup> / <sub>4</sub> , CB-1 <sup>1</sup> / <sub>4</sub> S, CB-1 <sup>1</sup> / <sub>2</sub> , CB-1 <sup>1</sup> / <sub>2</sub> S, CB-2,<br>CB-2S, CB-2 <sup>1</sup> / <sub>2</sub> , CB-2 <sup>1</sup> / <sub>2</sub> F, CB-3, CB-3F, CB-4                                    |                     |
| LOCK-WASHERS                       | G10027   | CB-4F, CB-4G, CB-5F, CB-5G, CB-6F, CB-6G  |                     |
|                                    | G10035   | CB-8F, CB-8G, CB-10F, CB-10G, CB-12F, CB-12G  |                     |
| LOWER NAMEPLATE RETAINERS          | V51093   | 3D-2S, 3DS-2G, 3DS-2S, 3D-2 <sup>1</sup> / <sub>2</sub> S, 3DS-2 <sup>1</sup> / <sub>2</sub> G, 3DS-2 <sup>1</sup> / <sub>2</sub> S, 3D-3S,<br>3DS-3G, 3DS-3S, 3DS-3B, 3DS-4B   |                     |
|                                    | V51094   | 3D-4S, 3DS-4G, 3DS-4S, 3D-5S, 3DS-5G, 3DS-5S, 3D-6S, 3DS-6G,<br>3DS-6S, 3D-8S, 3DS-8G, 3DS-8S, 3D-10S, 3DS-10G, 3DS-10S,<br>3DS-5B, 3DS-6B, 3DS-8B, 3DS-10B, 3DS-12B  |                     |
|                                    | V51095   | 3DS-12G, 3DS-12S, 3DS-14S, 3DS-14B, 3DS-16B   |                     |
| NAMEPLATES                         | G10017   | CB-4F   |                     |
|                                    | G10018   | CB-5F   |                     |
|                                    | G10019   | CB-6F   |                     |
|                                    | G10020   | CB-8F   |                     |
|                                    | G10064   | CB-4G   |                     |
|                                    | G10065   | CB-5G   |                     |
|                                    | G10066   | CB-6G   |                     |
|                                    | G10067   | CB-8G   |                     |
|                                    | V50896   | 3DS-14S   |                     |
|                                    | V50961   | 3DS-2S  |                     |
|                                    | V50962   | 3DS-2 <sup>1</sup> / <sub>2</sub> S   |                     |
|                                    | V50963   | 3DS-3S  |                     |
|                                    | V50964   | 3DS-4S  |                     |
|                                    | V50965   | 3DS-5S  |                     |
|                                    | V50966   | 3DS-6S  |                     |
|                                    | V50967   | 3DS-8S  |                     |
|                                    | V50968   | 3DS-10S   |                     |
|                                    | V50969   | 3DS-12S   |                     |
|                                    | V50971   | 3D-2S   |                     |
|                                    | V50972   | 3D-2 <sup>1</sup> / <sub>2</sub> S  |                     |
| V50973                             | 3D-3S    |   |                     |

**NOTE:** Obs. = Obsolete Model

## “WHERE USED” LIST (CONTINUED)

| CATEGORY               | PART NO.   | WHERE USED   | NOTES/SPECIFICATION |
|------------------------|--|--|---------------------|
| NAMEPLATES (CONTINUED) | V50974   | 3D-4S  |                     |
|                        | V50975   | 3D-5S  |                     |
|                        | V50976   | 3D-6S  |                     |
|                        | V50977   | 3D-8S  |                     |
|                        | V50978   | 3D-10S   |                     |
|                        | V50996   | CB-10F   |                     |
|                        | V50997   | CB-12F   |                     |
|                        | V50998   | CB-10G   |                     |
|                        | V50999   | CB-12G   |                     |
|                        | V51823   | 3DS-2G   |                     |
|                        | V51824   | 3DS-2 <sup>1</sup> / <sub>2</sub> G  |                     |
|                        | V51825   | 3DS-3G   |                     |
|                        | V51826   | 3DS-4G   |                     |
|                        | V51827   | 3DS-5G   |                     |
|                        | V51828   | 3DS-6G   |                     |
|                        | V51829   | 3DS-8G   |                     |
|                        | V51830   | 3DS-10G  |                     |
|                        | V51831   | 3DS-12G  |                     |
|                        | V57089   | 3DS-3B   |                     |
|                        | V57090   | 3DS-4B   |                     |
| V57091                 | 3DS-5B   |  |                     |
| V57092                 | 3DS-6B   |  |                     |
| V57093                 | 3DS-8B   |  |                     |
| V57094                 | 3DS-10B  |  |                     |
| V57095                 | 3DS-12B  |  |                     |
| V57096                 | 3DS-14B  |  |                     |
| V57097                 | 3DS-16B  |  |                     |
| NAMEPLATE CAPS         | G10025   | CB-4F, CB-4G, CB-5F, CB-5G, CB-6F, CB-6G, CB-8F, CB-8G, CB-10F, CB-10G   |                     |
|                        | V51005   | CB-12F, CB-12G   |                     |
|                        | V51111   | 3D-2S, 3DS-2G, 3DS-2S, 3D-2 <sup>1</sup> / <sub>2</sub> S, 3DS-2 <sup>1</sup> / <sub>2</sub> G, 3DS-2 <sup>1</sup> / <sub>2</sub> S, 3D-3S, 3DS-3G, 3DS-3S, 3DS-3B, 3DS-4B   |                     |
|                        | V51114   | 3D-4S, 3DS-4G, 3DS-4S, 3D-5S, 3DS-5G, 3DS-5S, 3D-6S, 3DS-6G, 3DS-6S, 3D-8S, 3DS-8G, 3DS-8S, 3D-10S, 3DS-10G, 3DS-10S, 3DS-5B, 3DS-6B, 3DS-8B, 3DS-10B, 3DS-12B   |                     |
| V51119                 | 3DS-12G, 3DS-12S, 3DS-14S, 3DS-14B, 3DS-16B  |  |                     |
| O-RINGS                | A03719   | EAS-1 <sup>1</sup> / <sub>2</sub> , EAS-2  |                     |
|                        | A03841   | EAS-1, EAS-1 <sup>1</sup> / <sub>4</sub>   |                     |
|                        | J94130   | SDG-3, DD-3X, DD-3Z, ED-3X, ED-3Z  |                     |
|                        | J94131   | SDG-4, EE-3X, EE-3Z, FE-3X, FE-3Z, GE-3X, GE-3Z  |                     |
|                        | J94140   | BA-3X, BA-3Z   |                     |
|                        | J94141   | SDG-2 <sup>1</sup> / <sub>2</sub> , BB-3X, BB-3Z, CB-3X, CB-3Z, CC-3X, CC-3Z, DA-3X, DA-3Z, DB-3X, DB-3Z, DC-3X, DC-3Z, EC-3X, EC-3Z   |                     |
|                        | J94142   | SDG-5, FF-3X, FF-3Z, GF-3X, GF-3Z  |                     |
|                        | J94143   | SDG-6, GG-3X, GG-3Z, HG-3X, HG-3Z  |                     |
|                        | J94144   | SDG-8, HH-3X, HH-3Z, JH-3X, JH-3Z  |                     |
| J94145                 | SDG-10, JJ-3X, JJ-3Z   |  |                     |
| PACKING                | F17000   | S-4, 3D-2S, 3DS-2G, 3DS-2S, 3D-2 <sup>1</sup> / <sub>2</sub> S, 3DS-2 <sup>1</sup> / <sub>2</sub> G, 3DS-2 <sup>1</sup> / <sub>2</sub> S, 3D-3S, 3DS-3G, 3DS-3S, 3DS-3B, 3DS-4B  |                     |
|                        | G10033   | CB-4F, CB-4G, CB-5F, CB-5G, CB-6F, CB-6G   |                     |
|                        | G10041   | CB-8F, CB-8G, CB-10F, CB-10G   |                     |
|                        | V51004   | CB-12F, CB-12G   |                     |
|                        | V51096   | 3D-4S, 3DS-4G, 3DS-4S, 3D-5S, 3DS-5G, 3DS-5S, 3D-6S, 3DS-6G, 3DS-6S, 3D-8S, 3DS-8G, 3DS-8S, 3D-10S, 3DS-10G, 3DS-10S, 3DS-5B, 3DS-6B, 3DS-8B, 3DS-10B, 3DS-12B   |                     |
|                        | V51097   | 3DS-12G, 3DS-12S, 3DS-14S, 3DS-14B, 3DS-16B  |                     |
| 118057                 | SA- <sup>3</sup> / <sub>4</sub> , SA-1, SA-1 <sup>1</sup> / <sub>4</sub> , SA-1 <sup>1</sup> / <sub>2</sub> , SB- <sup>3</sup> / <sub>4</sub> , SA-2, A-2 <sup>1</sup> / <sub>2</sub> , S-2 <sup>1</sup> / <sub>2</sub> , A-3, S-3, Obs. SA- <sup>3</sup> / <sub>4</sub> , Obs. SB- <sup>3</sup> / <sub>4</sub> , TB- <sup>3</sup> / <sub>4</sub> , TB-1, 3DX-1, 3DX-1 <sup>1</sup> / <sub>4</sub> , 3DX-1 <sup>1</sup> / <sub>2</sub> |  |                     |
| PACKING GLAND NUTS     | F16600   | S-4, 3D-2S, 3DS-2G, 3DS-2S, 3D-2 <sup>1</sup> / <sub>2</sub> S, 3DS-2 <sup>1</sup> / <sub>2</sub> G, 3DS-2 <sup>1</sup> / <sub>2</sub> S, 3D-3S, 3DS-3G, 3DS-3S, 3DS-3B, 3DS-4B  |                     |
|                        | G10026   | CB-4F, CB-4G, CB-5F, CB-5G, CB-6F, CB-6G   |                     |
|                        | G10034   | CB-8F, CB-8G, CB-10F, CB-10G   |                     |
|                        | V51002   | CB-12F, CB-12G   |                     |
|                        | V51183   | 3DS-12G, 3DS-12S, 3DS-14S, 3DS-14B, 3DS-16B  |                     |
|                        | V51281   | 3D-4S, 3DS-4G, 3DS-4S, 3D-5S, 3DS-5G, 3DS-5S, 3D-6S, 3DS-6G, 3DS-6S, 3D-8S, 3DS-8G, 3DS-8S, 3D-10S, 3DS-10G, 3DS-10S, 3DS-5B, 3DS-6B, 3DS-8B, 3DS-10B, 3DS-12B   |                     |
|                        | 118056   | SA- <sup>3</sup> / <sub>4</sub> , SA-1, SA-1 <sup>1</sup> / <sub>4</sub> , SA-1 <sup>1</sup> / <sub>2</sub> , SB- <sup>3</sup> / <sub>4</sub> , SA-2, A-2 <sup>1</sup> / <sub>2</sub> , S-2 <sup>1</sup> / <sub>2</sub> , A-3, S-3, Obs. SA- <sup>3</sup> / <sub>4</sub> , Obs. SB- <sup>3</sup> / <sub>4</sub> , 3DX-1, 3DX-1 <sup>1</sup> / <sub>4</sub> , 3DX-1 <sup>1</sup> / <sub>2</sub> |                     |

NOTE: Obs. = Obsolete Model

## “WHERE USED” LIST (CONTINUED)

| CATEGORY              | PART NO.       | WHERE USED   | NOTES/SPECIFICATION |
|-----------------------|----------------|--|---------------------|
| PACKING GLAND WASHERS | G10032         | CB-4F, CB-4G, CB-5F, CB-5G, CB-6F, CB-6G   |                     |
|                       | G10040         | CB-8F, CB-8G, CB-10F, CB-10G   |                     |
|                       | V51003         | CB-12F, CB-12G   |                     |
|                       | V51184         | 3DS-12G, 3DS-12S, 3DS-14S, 3DS-14B, 3DS-16B  |                     |
|                       | V51282         | 3D-4S, 3DS-4G, 3DS-4S, 3D-5S, 3DS-5G, 3DS-5S, 3D-6S, 3DS-6G, 3DS-6S, 3D-8S, 3DS-8G, 3DS-8S, 3D-10S, 3DS-10G, 3DS-10S, 3DS-5B, 3DS-6B, 3DS-8B, 3DS-10B, 3DS-12B                               |                     |
| RETAINER OR JAM NUTS  | J91634         | 3D-2S, 3DS-2G, 3DS-2S, 3D-2 <sup>1</sup> / <sub>2</sub> S, 3DS-2 <sup>1</sup> / <sub>2</sub> G, 3DS-2 <sup>1</sup> / <sub>2</sub> S, 3D-3S, 3DS-3G, 3DS-3S, 3DS-3B, 3DS-4B                   |                     |
|                       | J91635         | CB-4F, CB-4G, CB-5F, CB-5G, CB-6F, CB-6G, 3DS-4G, 3DS-5G, 3DS-6G, 3DS-6S, 3DS-5S, 3DS-4S, 3D-4S, 3D-5S, 3D-6S, 3DS-5B, 3DS-6B, 3DS-8B  |                     |
|                       | J91636         | CB-8F, CB-8G, CB-10F, CB-10G, CB-12F, CB-12G, 3D-8S, 3DS-8G, 3DS-8S, 3D-10S, 3DS-10G, 3DS-10S, 3DS-12G, 3DS-12S, 3DS-10B, 3DS-12B, 3DS-14B   |                     |
|                       | J91637         | 3DS-14S, 3DS-16B   |                     |
| RETAINER RINGS        | F02800         | SA-1, Obs. SA- <sup>3</sup> / <sub>4</sub> , Obs. SB- <sup>3</sup> / <sub>4</sub> , 3DX-1  |                     |
|                       | F06800         | S-4  |                     |
|                       | F20800         | SA-1 <sup>1</sup> / <sub>4</sub> , SA-1 <sup>1</sup> / <sub>2</sub> , SA-2, 3DX-1 <sup>1</sup> / <sub>4</sub> , 3DX-1 <sup>1</sup> / <sub>2</sub>  |                     |
|                       | F22200         | A-2 <sup>1</sup> / <sub>2</sub> , S-2 <sup>1</sup> / <sub>2</sub> , A-3, S-3   |                     |
|                       | G92000         | TFI-1 <sup>1</sup> / <sub>4</sub> , TFI-1 <sup>1</sup> / <sub>2</sub> , TFI-2, TFI-2 <sup>1</sup> / <sub>2</sub> , TFI-3, TFI-4, TFI-5, TFI-6, TFI-8, TB- <sup>3</sup> / <sub>4</sub> , TB-1 |                     |
|                       | G10029         | CB-4F, CB-4G, CB-5F, CB-5G, CB-6F, CB-6G   |                     |
|                       | G10037         | CB-8F, CB-8G, CB-10F, CB-10G   |                     |
|                       | J92344         | 3DX-1, 3DX-1 <sup>1</sup> / <sub>4</sub> , 3DX-1 <sup>1</sup> / <sub>2</sub>   |                     |
|                       | J92345         | CB-4F, CB-4G, CB-5F, CB-5G, CB-6F, CB-6G   |                     |
|                       | J92346         | CB-4F, CB-4G, CB-5F, CB-5G, CB-6F, CB-6G   |                     |
|                       | J92347         | CB-8F, CB-8G, CB-10F, CB-10G   |                     |
|                       | J92348         | CB-8F, CB-8G, CB-10F, CB-10G   |                     |
|                       | J92349         | CB-4F, CB-4G, CB-5F, CB-5G, CB-6F, CB-6G, CB-8F, CB-8G, CB-10F, CB-10G   |                     |
|                       | J92350         | SA- <sup>3</sup> / <sub>4</sub> , SB- <sup>3</sup> / <sub>4</sub>  |                     |
| V51008                | CB-12F, CB-12G |  |                     |
| SCALE PLATES          | G95594         | TFI-1 <sup>1</sup> / <sub>4</sub>  |                     |
|                       | G95595         | TFI-1 <sup>1</sup> / <sub>2</sub>  |                     |
|                       | G95596         | TFI-2  |                     |
|                       | G95597         | TFI-2 <sup>1</sup> / <sub>2</sub>  |                     |
|                       | G95598         | TFI-3  |                     |
|                       | G95915         | TFI-4  |                     |
|                       | G95916         | TFI-5  |                     |
|                       | G95917         | TFI-6  |                     |
| G95918                | TFI-8          |  |                     |
| SEAL RETAINERS        | G10013         | CB-4F, CB-4G   |                     |
|                       | G10014         | CB-5F, CB-5G   |                     |
|                       | G10015         | CB-6F, CB-6G   |                     |
|                       | G10016         | CB-8F, CB-8G   |                     |
|                       | V50686         | 3DX-1  |                     |
|                       | V50687         | Obs. 3DX-1 <sup>1</sup> / <sub>4</sub>   |                     |
|                       | V50688         | 3DX-1 <sup>1</sup> / <sub>2</sub>  |                     |
|                       | V50750         | 3DS-14S, 3DS-16B   |                     |
|                       | V50942         | 3D-2S, 3DS-2G, 3DS-2S, 3D-2 <sup>1</sup> / <sub>2</sub> S, 3DS-2 <sup>1</sup> / <sub>2</sub> G, 3DS-2 <sup>1</sup> / <sub>2</sub> S, 3D-3S, 3DS-3G, 3DS-3S, 3DS-3B                           |                     |
|                       | V50945         | 3D-4S, 3DS-4G, 3DS-4S, 3DS-5B  |                     |
|                       | V50946         | 3D-5S, 3DS-5G, 3DS-5S, 3DS-6B  |                     |
|                       | V50947         | 3D-6S, 3DS-6G, 3DS-6S, 3DS-8B  |                     |
|                       | V50948         | 3D-8S, 3DS-8G, 3DS-8S, 3DS-10B   |                     |
|                       | V50949         | 3D-10S, 3DS-10G, 3DS-10S, 3DS-12B  |                     |
|                       | V50950         | 3DS-12G, 3DS-12S, 3DS-14B  |                     |
|                       | V50994         | CB-10F, CB-10G   |                     |
|                       | V50995         | CB-12F, CB-12G   |                     |
|                       | V56889         | 3DX-1 <sup>1</sup> / <sub>4</sub>  |                     |
|                       | V58164         | 3DS-3G, 3D-3S, 3DS-3S, 3DS-4B  |                     |

**NOTE:** Obs. = Obsolete Model

## “WHERE USED” LIST (CONTINUED)

| CATEGORY                  | PART NO.                                  | WHERE USED  | NOTES/SPECIFICATION |
|---------------------------|---|---|---------------------|
| <b>SEAL RINGS</b>         | V50781                                    | 3DX-1   |                     |
|                           | V50782                                    | 3DX-1 <sup>1</sup> / <sub>4</sub>   |                     |
|                           | V50783                                    | 3DX-1 <sup>1</sup> / <sub>2</sub>   |                     |
|                           | V50793                                    | 3DS-14S, 3DS-16B  |                     |
|                           | V50932                                    | 3D-2, 3DS-2G, 3DS-2S, 3D-2 <sup>1</sup> / <sub>2</sub> S  |                     |
|                           | V50933                                    | 3DS-2 <sup>1</sup> / <sub>2</sub> G, 3DS-2 <sup>1</sup> / <sub>2</sub> S, 3DS-3B  |                     |
|                           | V50934                                    | 3D-3, 3DS-3G, 3DS-3S, 3DS-4B  |                     |
|                           | V50935                                    | CB-4F, CB-4G, 3D-4, 3DS-4G, 3DS-4S, 3DS-15B   |                     |
|                           | V50936                                    | CB-5F, CB-5G, 3D-5S, 3DS-5G, 3DS-5S, 3DS-6B   |                     |
|                           | V50937                                    | CB-6F, CB-6G, 3D-6S, 3DS-6G, 3DS-6S, 3DS-8B   |                     |
|                           | V50938                                    | CB-8F, CB-8G, 3D-8S, 3DS-8G, 3DS-8S, 3DS-10B  |                     |
|                           | V50939                                    | CB-10F, CB-10G, 3D-10S, 3DS-10G, 3DS-10S, 3DS-12B   |                     |
| V50940                    | CB-12F, CB-12G, 3DS-12G, 3DS-12S, 3DS-14B |   |                     |
| <b>SET SCREWS</b>         | J91999                                    | CB-12G  |                     |
|                           | J92020                                    | CB-4F, CB-4G, CB-5F, CB-5G, CB-6F, CB-6G, CB-8F, CB-8G, CB-10F, CB-10G, CB-12F  |                     |
| <b>SPRINGS</b>            | F66200                                    | TB-1  |                     |
|                           | F66800                                    | TFI-1 <sup>1</sup> / <sub>4</sub> , TFI-1 <sup>1</sup> / <sub>2</sub> , TFI-2, TFI-2 <sup>1</sup> / <sub>2</sub> , TFI-3, TFI-4, TFI-5, TFI-6, TFI-8, TB- <sup>3</sup> / <sub>4</sub> |                     |
|                           | V50952                                    | 3D-2S, 3DS-2G, 3DS-2S, 3D-2 <sup>1</sup> / <sub>2</sub> , 3DS-2 <sup>1</sup> / <sub>2</sub> G, 3DS-2 <sup>1</sup> / <sub>2</sub> S, 3DS-3B  |                     |
|                           | V50953                                    | 3D-3S, 3DS-3G, 3DS-3S, 3DS-4B   |                     |
|                           | V50954                                    | 3D-4S, 3DS-4G, 3DS-4S, 3D-5S, 3DS-5G, 3DS-5S, 3DS-5B, 3DS-6B  |                     |
|                           | V50955                                    | 3D-6S, 3DS-6G, 3DS-6S, 3DS-8B   |                     |
|                           | V50956                                    | 3D-8S, 3DS-8G, 3DS-8S, 3DS-10B  |                     |
|                           | V50957                                    | 3D-10S, 3DS-10G, 3DS-10S, 3DS-12B   |                     |
|                           | V50958                                    | 3DS-12G, 3DS-12S, 3DS-14B   |                     |
|                           | V51077                                    | 3DX-1   |                     |
|                           | V51078                                    | 3DX-1 <sup>1</sup> / <sub>4</sub>   |                     |
|                           | V51079                                    | 3DX-1 <sup>1</sup> / <sub>2</sub>   |                     |
| V51083                    | 3DS-14S, 3DS-16B                          |   |                     |
| <b>START-UP STRAINERS</b> | A91260                                    | BA-3X, BA-3Z  |                     |
|                           | A91261                                    | BB-3X, BB-3Z, CB-3X, CB-3Z, DA-3X, DA-3Z, DB-3X, DB-3Z  |                     |
|                           | A91262                                    | DD-3X, DD-3Z, ED-3X, ED-3Z, SDG-3   |                     |
|                           | A91263                                    | EE-3X, EE-3Z, FE-3X, FE-3Z, GE-3X, GE-3Z, SDG-4   |                     |
|                           | A91264                                    | FF-3X, FF-3Z, GF-3X, GF-3Z, SDG-5   |                     |
|                           | A91265                                    | GG-3X, GG-3Z, HG-3X, HG-3Z, SDG-6   |                     |
|                           | A91266                                    | HH-3X, HH-3Z, JH-3X, JH-3Z, SDG-8   |                     |
|                           | A91267                                    | JJ-3X, JJ-3Z, SDG-10  |                     |
|                           | A91268                                    | CC-3X, CC-3Z, DC-3X, DC-3Z, EC-3X, EC-3Z, SDG-2 <sup>1</sup> / <sub>2</sub>   |                     |
| <b>STEMS</b>              | G10005                                    | CB-4F, CB-4G  |                     |
|                           | G10006                                    | CB-5F, CB-5G  |                     |
|                           | G10007                                    | CB-6F, CB-6G  |                     |
|                           | G10008                                    | CB-8F, CB-8G  |                     |
|                           | V50767                                    | 3DX-1   |                     |
|                           | V50768                                    | 3DX-1 <sup>1</sup> / <sub>4</sub>   |                     |
|                           | V50769                                    | 3DX-1 <sup>1</sup> / <sub>2</sub>   |                     |
|                           | V50778                                    | 3DS-14S, 3DS-16B  |                     |
|                           | V50922                                    | 3D-2S, 3DS-2G, 3DS-2S, 3D-2 <sup>1</sup> / <sub>2</sub> , 3DS-2 <sup>1</sup> / <sub>2</sub> S, 3DS-2 <sup>1</sup> / <sub>2</sub> G, 3DS-3B  |                     |
|                           | V50924                                    | 3D-3S, 3DS-3G, 3DS-3S, 3DS-4B   |                     |
|                           | V50925                                    | 3D-4S, 3DS-4G, 3DS-4S, 3DS-5B   |                     |
|                           | V50926                                    | 3D-5S, 3DS-5G, 3DS-5S, 3DS-6B   |                     |
|                           | V50927                                    | 3D-6S, 3DS-6G, 3DS-6S, 3DS-8B   |                     |
|                           | V50928                                    | 3D-8S, 3DS-8G, 3DS-8S, 3DS-10B  |                     |
|                           | V50929                                    | 3D-10S, 3DS-10G, 3DS-10S, 3DS-12B   |                     |
|                           | V50930                                    | 3DS-12G, 3DS-12S, 3DS-14B   |                     |
|                           | V50989                                    | CB-10F, CB-10G  |                     |
|                           | V50990                                    | CB-12F, CB-12G  |                     |

**NOTE:** Obs. = Obsolete Model

## “WHERE USED” LIST (CONTINUED)

| CATEGORY                          | PART NO.  | WHERE USED  | NOTES/SPECIFICATION   |                      |
|-----------------------------------|---|---|---|----------------------|
| <b>STRAINERS</b>                  | A91270  | Obs. BZ-3, Obs. BA-3, BA-3X   | Steel   |                      |
|                                   | A91271  | BB-3X, CB-3X, DA-3X, DB-3X  | Steel   |                      |
|                                   | A91272  | DD-3X, ED-3X  | Steel   |                      |
|                                   | A91273  | EE-3X, FE-3X, GE-3X   | Steel   |                      |
|                                   | A91274  | FF-3X, GF-3X  | Steel   |                      |
|                                   | A91275  | GG-3X, HG-3X  | Steel   |                      |
|                                   | A91276  | HH-3X, JH-3X  | Steel   |                      |
|                                   | A91277  | JJ-3X   | Steel   |                      |
|                                   | A91278  | CC-3X, DC-3X, EC-3X   | Steel   |                      |
|                                   | A91280  | Obs. BZ-3, Obs. BA-3Z, BA-3Z  | Stainless Steel   |                      |
|                                   | A91281  | BB-3Z, CB-3Z, DA-3Z, DB-3Z  | Stainless Steel   |                      |
|                                   | A91282  | Obs. DC-3, DD-3Z, ED-3Z, SDG-3  | Stainless Steel   |                      |
|                                   | A91283  | EE-3Z, FE-3Z, GE-3Z, SDG-4  | Stainless Steel   |                      |
|                                   | A91284  | SDG-5, FF-3Z, GF-3Z   | Stainless Steel   |                      |
|                                   | A91285  | GG-3Z, HG-3Z, SDG-6   | Stainless Steel   |                      |
|                                   | A91286  | HH-3Z, JH-3Z, SDG-8   | Stainless Steel   |                      |
| A91287                            | JJ-3Z, SDG-10   | Stainless Steel   |   |                      |
| A91288                            | CC-3Z, DC-3Z, SDG-2 <sup>1</sup> / <sub>2</sub> , EC-3Z | Stainless Steel   |   |                      |
| <b>STRAINER &amp; GASKET KITS</b> | 118036  | B-38, B-38TU, F-3, F-8, F-3TU, F-8TU, FB-38, FB-38TU, 6, 8, 8TU   |   |                      |
|                                   | 189160  | B7-12, 7  |   |                      |
| <b>TEFLON WASHERS</b>             | G10031  | CB-4F, CB-4G, CB-5F, CB-5G, CB-6F, CB-6G  |   |                      |
|                                   | G10039  | CB-8F, CB-8G, CB-10F, CB-10G, CB-12F, CB-12G  |   |                      |
| <b>TUBE GLASS</b>                 | G91900  | TFI-1 <sup>1</sup> / <sub>4</sub> , TFI-1 <sup>1</sup> / <sub>2</sub> , TFI-2, TFI-2 <sup>1</sup> / <sub>2</sub> , TFI-3  | Clear glass   |                      |
|                                   | G91904  | TFI-1 <sup>1</sup> / <sub>4</sub> , TFI-1 <sup>1</sup> / <sub>2</sub> , TFI-2, TFI-2 <sup>1</sup> / <sub>2</sub> , TFI-3, TFI-4, TFI-5, TFI-6, TFI-8                          | Etched glass  |                      |
|                                   | G91908  | TB- <sup>3</sup> / <sub>4</sub>   |   |                      |
|                                   | G91910  | TB-1  |   |                      |
| <b>UPPER NAMEPLATE RETAINERS</b>  | V51090  | 3D-2S, 3DS-2G, 3DS-2S, 3D-2 <sup>1</sup> / <sub>2</sub> S, 3DS-2 <sup>1</sup> / <sub>2</sub> G, 3DS-2 <sup>1</sup> / <sub>2</sub> S,<br>3D-3S, 3DS-3G, 3DS-3S, 3DS-3B, 3DS-4B |   |                      |
|                                   | V51091  | 3D-4S, 3DS-4G, 3DS-4S, 3D-5S, 3DS-5G, 3DS-5S, 3D-6S, 3DS-6G,<br>3DS-6S, 3D-8S, 3DS-8G, 3DS-8S, 3D-10S, 3DS-10G, 3DS-10S,<br>3DS-5B, 3DS-6B, 3DS-8B, 3DS-10B, 3DS-12B          |   |                      |
|                                   | V51092  | 3DS-12G, 3DS-12S, 3DS-14S, 3DS-14B, 3DS-16B   |   |                      |
| CATEGORY                          | PART NO.  | PART DESCRIPTION  | WHERE USED  | NOTES/SPECIFICATION  |
| <b>MISCELLANEOUS VALVE PARTS</b>  | 109024  | Operator  | CT-24, CTS-7524, CTF-10024  |                      |
|                                   | 113100  | Readout Valve Sets  | All Circuit Setter Models & All Triple Duty Valve Models  | 50 pairs per package |
|                                   | 113102  | Readout Probe Sets  | All Circuit Setter Models & All Triple Duty Valve Models  | 6 pairs per package  |
|                                   | 118029  | Diaphragm   | All Pressure Reducing Valve & Dual Unit Valve Models  |                      |
|                                   | 118855  | Lever, Button & Gasket  | 107A  |                      |
|                                   | 118861  | PRV Repair Kit  | All Pressure Reducing Valve & Dual Unit Valve Models  |                      |
|                                   | 189137  | Heat Motor Assembly   | CT-24, CTS-7524, CTF-10024  | 6 per package        |
|                                   | 189138  | Gland Assembly  | CT-24, CTS-7524, CTF-10024  | 6 per package        |
|                                   | 189139  | Bonnet & Retainer Assembly  | CT-24, CTS-7524, CTF-10024  | 6 per package        |
|                                   | 189143  | Heat Motor Kit  | Obs. M-1  |                      |
|                                   | A03717  | Diffuser  | EAS-1 <sup>1</sup> / <sub>2</sub> , EAS-2   |                      |
|                                   | A03718  | Wire Brush  | EAS-1 <sup>1</sup> / <sub>2</sub> , EAS-2   |                      |
|                                   | A03723  | Air Vent  | EAS-2   |                      |
|                                   | A03836  | Diffuser  | EAS-1, EAS-1 <sup>1</sup> / <sub>4</sub>  |                      |
|                                   | A03837  | Wire Brush  | EAS-1, EAS-1 <sup>1</sup> / <sub>4</sub>  |                      |
|                                   | A03842  | Air Vent  | EAS-1, EAS-1 <sup>1</sup> / <sub>4</sub> , EAS-1 <sup>1</sup> / <sub>2</sub>  |                      |
|                                   | F42800  | Snap Ring   | SA- <sup>3</sup> / <sub>4</sub> , SA-1, SA-1 <sup>1</sup> / <sub>4</sub> , SA-1 <sup>1</sup> / <sub>2</sub> , SB- <sup>3</sup> / <sub>4</sub> , SA-2, A-2 <sup>1</sup> / <sub>2</sub> , S-2 <sup>1</sup> / <sub>2</sub> ,<br>A-3, S-3, Obs. SA- <sup>3</sup> / <sub>4</sub> , Obs. SB- <sup>3</sup> / <sub>4</sub> , 3DX-1, 3DX-1 <sup>1</sup> / <sub>4</sub> , 3DX-1 <sup>1</sup> / <sub>2</sub> |                      |
|                                   | F62800  | Indicator Disc  | TB- <sup>3</sup> / <sub>4</sub>   |                      |
|                                   | F67200  | Sealing Ring  | TFI-1 <sup>1</sup> / <sub>4</sub> , TFI-1 <sup>1</sup> / <sub>2</sub> , TFI-2, TFI-2 <sup>1</sup> / <sub>2</sub> , TFI-3, TFI-4, TFI-5, TFI-6,<br>TFI-8, TB- <sup>3</sup> / <sub>4</sub> , TB-1   | 4 required           |
|                                   | F69000  | Hanger  | TFI-1 <sup>1</sup> / <sub>4</sub> , TFI-1 <sup>1</sup> / <sub>2</sub> , TFI-2, TFI-2 <sup>1</sup> / <sub>2</sub> , TFI-3, TFI-4, TFI-5, TFI-6,<br>TFI-8, TB- <sup>3</sup> / <sub>4</sub> , TB-1   |                      |
|                                   | F69200  | Guide Wire  | TFI-1 <sup>1</sup> / <sub>4</sub> , TFI-1 <sup>1</sup> / <sub>2</sub> , TFI-2, TFI-2 <sup>1</sup> / <sub>2</sub> , TFI-3, TFI-4, TFI-5, TFI-6,<br>TFI-8, TB- <sup>3</sup> / <sub>4</sub> , TB-1   |                      |
|                                   | G95000  | Angle Valve   | TFI-1 <sup>1</sup> / <sub>4</sub> , TFI-1 <sup>1</sup> / <sub>2</sub> , TFI-2, TFI-2 <sup>1</sup> / <sub>2</sub> , TFI-3, TFI-4, TFI-5,<br>TFI-6, TFI-8   | 2 required           |
|                                   | G97030  | Readout Valve Set   | All Circuit Setter Models & All Triple Duty Valve Models  |                      |
|                                   | G97032  | Readout Probe Set   | All Circuit Setter Models & All Triple Duty Valve Models  |                      |
|                                   | J92135  | Nameplate Screw   | CB-4F, CB-4G, CB-5F, CB-5G, CB-6F, CB-6G, CB-8F,<br>CB-8G, CB-10F, CB-10G, CB-12F, CB-12G, All Triple Duty<br>Valve Models except 3DX-1, 3DX-1 <sup>1</sup> / <sub>4</sub> & 3DX-1 <sup>1</sup> / <sub>2</sub>  | 2 required           |
|                                   | V01340  | Cover   | CT-24, CTS-7524, CTF-10024  |                      |
|                                   | V14609  | Strainer Nut  | All Pressure Reducing Valve & Dual Unit Valve Models  |                      |
|                                   | V50740  | Retainer  | 3DX-1, 3DX-1 <sup>1</sup> / <sub>4</sub> , 3DX-1 <sup>1</sup> / <sub>2</sub>  |                      |
| V51657                            | Tail Piece Gasket                                       | B-38TU, F-3TU, F-8TU, FB-38TU, 8TU  |   |                      |
| V51658                            | Rubber Check Valve                                      | All Pressure Reducing Valve & Dual Unit Valve Models  | Round   |                      |

**NOTE:** Obs. = Obsolete Model

# TROUBLESHOOTING HYDRONIC SYSTEM PROBLEMS

Below and on the following page are four guides for troubleshooting various problems found in typical hydronic heating systems. Each guide was developed by Bob DeWyze, Director of Training and Education for ITT Fluid Handling Division (retired). Familiarization with this information may provide insight in preventing future repairs required for pumps, valves and other hydronic accessories found in this service parts catalog.

| PUMPING SYSTEM TROUBLE ANALYSIS GUIDE                         |  |  |
|---|--|--|
| COMPLAINT   | POSSIBLE CAUSE   | RECOMMENDED ACTION   |
| No circulation  | Set screw not tight, coupler loose on shaft<br>Impeller slipping on shaft<br><br>Air-bound system<br>Air-bound pump<br>Broken pump coupler<br>Clogged impeller or piping<br>System valve closed<br>Pump electrical circuit broken  | Tighten set screw in shaft recess.<br>Check to see if impeller is placed on the key way of the shaft.<br>Tighten impeller nut.<br>Vent system<br>Vent pump casing<br>Replace; check alignment<br>Locate and remove obstruction<br>Open<br>Check all related low and line voltage circuits.   |
| Inadequate circulation  | Air-bound system<br>Air-bound pump<br>Clogged impeller or piping<br>Clogged strainer<br>Pump impeller damaged<br>Insufficient NPSH (net positive suction head)<br>Pump too small<br>Partially air-bound pump<br>Pump running backwards (three phase)<br>Improper motor speed | Vent system<br>Vent pump casing<br>Locate and remove obstruction<br>Remove and clean screen<br>Replace<br>Lower pump or raise pressure or relocate<br>Replace pump or impeller<br>Vent pump casing<br>Reverse any two motor leads<br>Check wiring and voltage  |
| Pump or system noise  | Entrained air<br>Pump cavitation<br>Pump misalignment<br>Worn pump coupler<br>Excessive water velocity<br>Poor foundation (base-mounted pumps only)<br>Pipe vibration  | Vent system<br>Lower pump or raise pressure or relocate (see note below)<br>Re-align pump<br>Replace; check alignment of shafts - replace sagging motor mounts<br>Install balancing cocks or parallel piping.<br>Provide rigid foundation with adequate grouting.<br>Provide adequate pipe support.  |
| Premature failure of pump components                          | Improper pump (size/type)<br>Improper pump location<br>Pump misalignment<br>Excessive water treatment<br>Over-oiling of pump<br>Under-oiling of pump<br>Pump operating close to or beyond end point of curve<br>Excessive piping load  | Replace<br>Relocate<br>Re-align<br>Check manufacturer's instructions<br>Check manufacturer's instructions<br>Check manufacturer's instructions<br>Balance system<br>Provide proper pipe support  |
| Seal failures within 1 year period or less in a closed system | Excessive dirt, sand and oxides<br>Excessive or improper water treatment<br><br>Pump Cavitation:<br>1. Improper selection<br>2. Compression tank location<br>Air-seal without lubricant (water)<br>Excessive temperatures<br>Pumps run without fluid                         | Clean system<br>Check for proper water treatment recommendations from pump manufacturer.<br><br>Check pump operation on its curve - overloading<br>High head pump must have compression tank on suction side of pump.<br>Vent air from pump volute<br>Check type of seal and max. operating temperature from manufacturer.<br>Pumps must be primed before operation. |
| Seal pitting<br>• Oxygen corrosion<br>• Magnetic iron oxide   | Caused by wear and excessive amounts of free oxygen.<br>Fresh water feeding carries oxygen into the system.  | Check if system has a constant leak.   |

Note: Cavitation can be identified by low rumbling or sharp rattling noises. This situation is created by the lack of available net positive suction head (NPSH). The pressure at some point in the pump falls below the vapor pressure of the water causing flashing and the formation of bubbles, which are carried into the volute where the higher pressure causes them to implode. This can eventually destroy the pump.

| AIR CONTROL SYSTEM PROBLEMS   |   |   |
|---|---|---|
| COMPLAINT   | POSSIBLE CAUSE  | RECOMMENDED ACTION  |
| Waterlogged compression tank  | Gravity circulation between boiler and tank<br>Leak in tank<br>Leak in gauge glass. Top gasket dries out allowing air to escape.  | Install air control system<br>Check with soap solution - replace<br>Check tapping - would most likely be in upper tapping   |
| Insufficient air control in air control devices<br>Boiler top outlet fittings | Dip tube not 2½" below water line in boiler   | This is almost impossible to find without taking the supply piping on the boiler apart.   |
| In-Line fitting not working properly  | Velocity too high through fitting for air separation.<br>Initial system start-up not performed properly<br>Improper pitch in piping to the tank<br><br>Leaks in system piping | Check size of fitting - it should be the same as the pipe size<br>Check manufacturer's instructions<br>Check to make sure horizontal pipe is pitched towards the compression tank.<br>Check for leaks |
| No heat radiation   | Air-bound   | Vent  |

# TROUBLESHOOTING HYDRONIC SYSTEM PROBLEMS (CONT.)

| VALVE SYSTEM TROUBLE ANALYSIS GUIDE  |  |   |
|--|--|---|
| COMPLAINT  | POSSIBLE CAUSE   | RECOMMENDED ACTION  |
| No circulation<br>Relief valve opens                                       | Set screw not tight, coupler loose on shaft<br>Defective relief valve<br>Compression tank undersized<br>Waterlogged compression tank<br>Run-away burner<br>Fuel valve stuck in open position<br>Pump not operating<br>High limit control fails<br>Defective reducing valve<br>System operating pressure too high<br>Dirt on seal | Tighten set screw in shaft recess<br>Replace<br>Check for proper size - replace<br>Install air control system or drain tank<br>Check controls<br>Check valve<br>Check pump<br>Check control<br>Clean or replace<br>Check static pressure and temperature operation<br>Lift handle rapidly to discharge dirt - still drips - replace |
| Valve drips  |  |   |
| Reducing valve failures  | Valve does not feed<br>Strainer plugged<br>Valve seat scaled shut  | Check if valve is scaled<br>Clean or replace<br>Turn adjustment screw all the way down to free - if it doesn't - replace  |
| Reducing valve does not reduce pressure<br>Relief valve pops - hot or cold | City pressure too high for valve<br>Reducing valve sticking in open position   | Check valve limitation and replace with higher pressure-rated valve.<br>Check valve, replace if necessary   |
| Flo-control valve problems-<br>Gravity circulation                         | Dirt on seat<br>Stem not turned down all the way<br>Valve body not installed in a horizontal position<br>Air in upper part of valve body<br>Thermostat not working properly  | Take cover off and wipe seat<br>Turn handle on stem all the way and seat<br>If in a vertical position, change to horizontal, use straight or angle valve<br>Open cover and vent<br>Check thermostat   |
| Pulsating action<br>Zone valves will not operate (see note below)          | Power pill burned out<br>Sticking seal assembly valve will not seal  | Check & replace - check electrical connections<br>Check and clean stem and seat for build-up of mineral scale   |

Note: If valve does not operate, install in a manual full open or partial position to prevent freeze-up.

| MISCELLANEOUS SYSTEM PROBLEMS          |  |   |
|--|--|---|
| COMPLAINT                              | POSSIBLE CAUSE   | RECOMMENDED ACTION  |
| Insufficient heat in one or more zones | Air binding<br>Clogged zone piping<br>Defective zone valve<br>Unbalanced circuits<br>Undersized radiation<br>Broken coupler on pump<br>Motor burn-out<br>Power off   | Install air control<br>Locate and remove obstruction<br>Repair or replace<br>Balance<br>Add radiation or more insulation - increase water temperature<br>Check alignment of shafts - replace sagging motor mounts<br>Check pump motor<br>Check electrical connections - power source                            |
| Overheating - cold or mild weather     | Gravity circulation<br>Defective flo-control valve<br>Zone valve stuck in open position<br>Thermostat not operating<br>Flo-control valve stem in open position<br>Fuel valve stuck in open position<br>Controls not operating properly | Install flo-control valve<br>Clean or repair or replace<br>Check - repair or replace<br>Check - replace<br>Close valve<br>Check - replace if needed<br>Check  |
| Pounding or waterhammer                | Lack of system pressure<br>Over-sized compression tank<br>Excessive boiler temperature<br>Pumping into the boiler using high head pumps<br>Use of solenoid valves  | Check if static pressure is correct for system<br>See note below<br>Check to see if water is circulating through boiler - stuck fuel valve<br>(1) Increase static pressure above pump head if possible.<br>(2) Move pump to pump away from boiler and discharge into system.<br>Do not use on hydronic systems. |
| Crackling sound                        | Boiler full of lime (mineral compounds)  | Clean and flush   |

Note: If a compression tank is so large that system pressure does not build-up in the proper range with temperature increase, boiling may occur in piping or radiation at the high point of the system, particularly when pumping into the boiler.

For additional hydronic system troubleshooting information, contact your local Bell & Gossett Representative.



# ITT

## BELL & GOSSETT PRODUCTS

### Stocked ... Sold ... Serviced EVERYWHERE!

FOR MORE DETAILS CALL YOUR LOCAL BELL & GOSSETT REPRESENTATIVE

#### ALABAMA

Mangham & Associates, Inc.  
Irontdale (Birmingham)  
Phone: 205/956-2362

#### ALASKA

Columbia Hydronics Co.  
Anchorage  
Phone: 907/563-3327  
907/563-3337

#### ARIZONA

J & B Sales Company  
Phoenix  
Phone: 602/258-1545

#### ARKANSAS

Johnson & Scott, Inc.  
Little Rock  
Phone: 501/803-9520  
Hydronic Technology Inc.  
Shreveport, LA  
Phone: 318/797-1500  
Boone & Boone Sales Co., Inc.  
Tulsa, OK  
Phone: 918/664-9756

#### CALIFORNIA

California Hydronics Corp.  
Hayward (San Francisco)  
Phone: 510/293-1993  
Rocklin (Sacramento)  
Phone: 510/293-1993  
San Jose  
Phone: 408/295-5874  
Dawson Co.  
Altadena (Los Angeles)  
Phone: 626/797-9710  
San Diego  
Phone: 858/541-7867

#### COLORADO

McNevin Company  
Aurora (Denver)  
Phone: 303/322-0165

#### CONNECTICUT

F.I.A., Inc.  
Middleton  
Phone: 781-938-8900  
Woburn (Boston) MA  
Phone: 781/938-8900

#### DELAWARE

R. D. Bitzer Co., Inc.  
Bensalem, PA  
Phone: 215/604-6600  
Cummins-Wagner Co., Inc.  
Annapolis Junction, MD  
Phone: 800/966-1277  
301/490-9007

#### FLORIDA

George A. Israel Jr., Inc.  
Jacksonville  
Phone: 904/355-7867  
Miami  
Phone: 305/592-5343  
Orlando  
Phone: 407/423-5078  
Tampa  
Phone: 813/839-2161  
79 Holly Circle  
Tequesta, FL 33469  
Phone: 561/248-3556

#### GEORGIA

James M. Pleasants Co., Inc.  
Duluth  
Phone: 678/507-1091  
Norcross  
Phone: 800/522-1861  
678/507-1091  
George A. Israel Jr., Inc.  
Jacksonville, FL  
Phone: 904/355-7867

#### HAWAII

CBC Inc.  
Kailua  
Phone: 808/263-8838

#### IDAHO

Gritton & Associates, Inc.  
Salt Lake City, UT  
Phone: 801/486-0767  
Columbia Hydronics Co.  
Boise  
Phone: 208/345-2744

#### ILLINOIS

Bornquist, Inc.  
Chicago  
Phone: 773/774-2800  
Blackmore & Glunt, Inc.  
Maryland Hgts. (St. Louis) MO  
Phone: 314/878-4313  
Sandberg Co., Inc.  
East Moline  
Phone: 309/796-2371  
Hydronic & Steam Equip. Co., Inc.  
Indianapolis, IN  
Phone: 800/669-4926  
317/577-8326

#### INDIANA

Hydronic & Steam Equip. Co., Inc.  
Indianapolis  
Phone: 800/669-4926  
317/577-8326  
Evansville  
Phone: 800/473-2753  
812/473-0330  
Ft. Wayne  
Phone: 260/489-5785  
South Bend  
Phone: 800/932-6490  
574/234-6005

#### Bornquist, Inc.

Chicago, IL  
Phone: 773/774-2800  
Blackmore & Glunt, Inc.  
Cincinnati, OH  
Phone: 513/489-5225

#### IOWA

Products, Inc.  
Des Moines  
Phone: 515/288-5738  
Sandberg Co., Inc.  
East Moline, IL  
Phone: 309/796-2371  
Verne Simmonds Co.  
Omaha, NE  
Phone: 402/592-3131

#### KANSAS

Blackmore & Glunt, Inc.  
Lenexa (Kansas City)  
Phone: 913/469-5715

#### KENTUCKY

Blackmore & Glunt, Inc.  
Cincinnati, OH  
Phone: 513/489-5225  
Hydronic & Steam Equip. Co., Inc.  
Evansville, IN  
Phone: 800/473-2753  
812/473-0330  
Johnson & Scott, Inc.  
Nashville, TN  
Phone: 615/254-5454

#### LOUISIANA

Hydronic Technology Inc.  
New Orleans  
Phone: 800/365-6746  
504/827-1163  
Shreveport  
Phone: 800/673-5737  
318/797-1500

#### MAINE

F.I.A., Inc.  
Woburn (Boston) MA  
Phone: 781/938-8900

#### MARYLAND

Cummins-Wagner Co., Inc.  
Annapolis Junction  
Phone: 800/966-1277  
301/490-9007  
Thermoflo Equipment Co., Inc.  
Pittsburgh, PA  
Phone: 412/366-2012

#### MASSACHUSETTS

F.I.A., Inc.  
Woburn (Boston)  
Phone: 781/938-8900  
**MICHIGAN**  
R. L. Deppmann Co.  
Southfield (Detroit)  
Phone: 248/354-3710  
Grand Rapids  
Phone: 616/656-0821  
Bridgeport  
Phone: 989/652-3049  
Hydro-Flo Products, Inc.  
Brookfield (Milwaukee), WI  
Phone: 262/781-2810

#### MINNESOTA

Mulcahy Company  
Eagan  
Phone: 651/686-8580  
**MISSISSIPPI**  
Hydronic Technology Inc.  
New Orleans, LA  
Phone: 800/365-6746  
504/827-1163  
Johnson & Scott, Inc.  
Little Rock, AR  
Phone: 501/803-9520

#### MISSOURI

Blackmore & Glunt, Inc.  
Lenexa (Kansas City) KS  
Phone: 913/469-5715  
Maryland Hgts. (St. Louis)  
Phone: 314/878-4313

#### MONTANA

Columbia Hydronics Co.  
Spokane, WA  
Phone: 509/242-1118

#### NEBRASKA

Verne Simmonds Co.  
Omaha  
Phone: 402/592-3131

#### NEVADA

California Hydronics Corp.  
Rocklin, CA (Northwest NV)  
Phone: 510/293-1993  
Gritton & Associates, Inc.  
Salt Lake City, UT  
Phone: 801/486-0767

#### NEW HAMPSHIRE

F.I.A., Inc.  
Woburn (Boston) MA  
Phone: 781/938-8900

#### NEW JERSEY

Wallace-Eannace Assoc., Inc.  
Franklin Lakes  
Phone: 201/891-9550  
R. D. Bitzer Co., Inc.  
Bensalem, PA  
Phone: 215/604-6600

#### NEW MEXICO

Boyd Engineering Co., Inc.  
Albuquerque  
Phone: 505/275-1250

#### NEW YORK

Wallace-Eannace Assoc., Inc.  
Plainview (NYC)  
Phone: 516/454-9300  
Frank P. Langley Co., Inc.  
E. Rochester  
Phone: 585/248-5010  
Amherst (Buffalo)  
Phone: 716/691-7575  
Johnson City  
Phone: 607/766-9950  
Albany  
Phone: 518/459-1060  
Syracuse Thermal Products, Inc.  
East Syracuse  
Phone: 315/437-7321

#### NORTH CAROLINA

James M. Pleasants Co., Inc.  
Greensboro  
Phone: 800/365-9010  
336/378-9911  
Charlotte  
Phone: 704/545-0145  
Raleigh  
Phone: 919/845-1960  
Wilmington  
Phone: 910/794-5447

#### NORTH DAKOTA

Mulcahy Company.  
Eagan, MN  
Phone: 651/686-8580

#### OHIO

Blackmore & Glunt, Inc.  
Cincinnati  
Phone: 513/489-5225  
R. L. Deppmann Co.  
Richfield  
Phone: 330/468-1102

#### OHIO (Cont'd.)

Steffens-Shultz, Inc.  
Columbus  
Phone: 614/274-5515  
Dayton, Ohio  
Phone: 937/454-4980  
Thermoflo Equipment Co., Inc.  
Pittsburgh, PA  
Phone: 412/366-2012

#### OKLAHOMA

Boone & Boone Sales Co., Inc.  
Oklahoma City  
Phone: 405/525-7475  
Tulsa  
Phone: 918/664-9756

#### OREGON

Columbia Hydronics Co.  
Vancouver, WA  
Phone: 360/883-2600

#### PENNSYLVANIA

R. D. Bitzer Co., Inc.  
Bensalem  
Phone: 215/604-6600  
Thermoflo Equipment Co., Inc.  
Pittsburgh  
Phone: 412/366-2012

#### Frank P. Langley Co., Inc.

Amherst (Buffalo) NY  
Phone: 716/691-7575

#### RHODE ISLAND

F.I.A., Inc.  
Woburn (Boston) MA  
Phone: 781/938-8900

#### SOUTH CAROLINA

James M. Pleasants Co., Inc.  
Greensboro, NC  
Phone: 800/365-9010  
336/378-9911  
Columbia  
Phone: 803/798-1405  
Greenville  
Phone: 864/232-0200

#### SOUTH DAKOTA

Mulcahy Company  
Eagan, MN  
Phone: 651/686-8580  
Verne Simmonds Co.  
Omaha, NE  
Phone: 402/592-3131

#### TENNESSEE

Johnson & Scott, Inc.  
Nashville  
Phone: 615/254-5454  
Cordova (Memphis)  
Phone: 901/388-2919  
James M. Pleasants Co., Inc.  
Greensboro, NC  
Phone: 800/365-9010  
336/378-9911  
Knoxville  
Phone: 865/584-5054

#### TEXAS

Boyd Engineering Co., Inc.  
Albuquerque, NM  
Phone: 505/275-1250  
Oslin Nation Co.  
Dallas  
Phone: 214/631-5650  
Ft. Worth  
Phone: 817/590-2500

#### TEXAS (Cont'd.)

Oslin Nation Co. (Cont'd)  
Houston  
Phone: 713/699-3500  
San Antonio  
Phone: 800/243-7756  
210/342-5544

#### UTAH

Gritton & Associates, Inc.  
Salt Lake City  
Phone: 801/486-0767

#### VERMONT

F.I.A., Inc.  
Woburn (Boston) MA  
Phone: 781/938-8900

#### VIRGINIA

TLA, Inc.  
Richmond  
Phone: 804/321-4444  
Virginia Beach  
Phone: 757/497-3567  
Cummins-Wagner Co., Inc.  
Annapolis Junction, MD  
Phone: 800/966-1277  
301/490-9007

#### WASHINGTON

Columbia Hydronics Co.  
Renton  
Phone: 425/271-5870  
Spokane  
Phone: 509/242-1118  
Vancouver  
Phone: 360/883-2600

#### WASHINGTON, DC

Cummins-Wagner Co., Inc.  
Annapolis Junction, MD  
Phone: 800/966-1277  
301/490-9007

#### WEST VIRGINIA

Blackmore & Glunt, Inc.  
Cincinnati, OH  
Phone: 513/489-5225  
TLA, Inc.  
Richmond, VA  
Phone: 804/321-4444

#### Thermoflo Equipment Co., Inc.

Pittsburgh, PA  
Phone: 412/366-2012

#### WISCONSIN

Hydro-Flo Products, Inc.  
Brookfield (Milwaukee)  
Phone: 262/781-2810  
Mulcahy Company  
Eagan, MN  
Phone: 651/686-8580

#### WYOMING

Gritton & Associates, Inc.  
Salt Lake City, UT  
Phone: 801/486-0767  
J. E. McNevin Co.  
Aurora (Denver), CO  
Phone: 303/322-0165

#### INTERNATIONAL:

Visit our website or contact our office at the address shown below.

© COPYRIGHT 2007 BY  
ITT CORPORATION  
PRINTED IN U.S.A. 11-07

THE ITT ENGINEERED BLOCKS SYMBOL AND  
ENGINEERED FOR LIFE ARE REGISTERED  
TRADEMARKS OF ITT CORPORATION

ITT

8200 N. Austin Avenue  
Morton Grove, IL 60053  
Phone: (847) 966-3700  
Fax: (847) 966-9052  
www.bellgossett.com

