

# ACCESSORY KIT INSTALLATION INSTRUCTIONS

1NP0347 / 1NP0348 / 1NP0349

PROPANE CONVERSION ACCESSORY - INDUCED COMBUSTION FURNACES

MODELS - P\*HU/P\*DN/P\*UR/P\*DH/FL8/G9T-UP/G9T-DH/FG9-UP/  
FG9-DH/G8T-UH/L8T-UH/G8T-DN/L8T-DN/GF9/GM9

## WARNING

*This conversion kit is to be installed by a qualified service agency in accordance with the manufacturer's instructions and all applicable codes and requirements of the authority having jurisdiction. If the information in these instructions are not followed exactly, a fire, an explosion or production of carbon monoxide may result causing property damage, personal injury or loss of life. The qualified service agency is responsible for the proper installation of this kit. The installation is not proper and complete until the operation of the converted appliance is checked as specified in the manufacturer's instructions supplied with the kit.*

## CAUTION

*The conversion of new certified central heating gas appliances must conform to directions outlined in this instruction. Installation must be made in accordance with American National Standard National Fuel Gas Code, ANSI Z223.1-latest edition, unless superseded by local codes. For Canadian installations, the conversion shall be carried out in accordance with the requirements of the Provincial authorities having jurisdiction and in accordance with the CAN1-B149.1 and .2 installation codes.*

*The manufacturer accepts no responsibility for malfunctions due to improper conversions*

## CAUTION

*Lo-NOx furnaces requiring propane (LP) gas must have the NOx screens removed prior to operation. Failure to do so may result in operational problems and/or reduced heat exchanger life. Follow the instructions below for removal of the NOx screens.*

## GENERAL

This kit is intended for the conversion of new equipment only, from natural gas to propane gas operation.

All unit installations above 2,000 ft. must be field derated as required by the National Fuel Gas Code, ANSI Z223.1 (latest edition), or in Canada, CAN/CGA B149.1 or .2 and all other applicable local codes and utility requirements.

This instruction covers the conversion of this unit when it is equipped with a White-Rodgers gas valve. The installation instruction supplied with the unit is to be used for all other aspects of the installation.

PROPANE CONVERSION KIT APPLICATION		
MODELS	USAGE (INPUTS)	ACCESSORY
P*HU/P*DN/FL8 G8T-UH/L8T-UH/ G8T-DN/L8T-DN	40, 80, & 100 MBH <u>Only</u>	1NP0347
P*HU/P*DN/FL8 G8T-UH/L8T-UH/ G8T-DN/L8T-DN	60, 115 & 130 MBH <u>Only</u>	1NP0348
P*HU	160 MBH <u>Only</u>	1NP0349
P*UR/P*DH G9T-UP/FG9-UP G9T-DH/FG9-DH	40 - 120 MBH <u>Only</u>	1NP0347
P*UR/G9T-UP/FG9-UP	140 MBH <u>Only</u>	1NP0349
GF9/GM9	All Models	1NP0347

## WARNING

*Improper installation, adjustment, service or maintenance can cause injury or property damage; therefore, only a qualified installer or qualified service personnel should perform this conversion.*

## CONTENTS OF KIT

Parts Common to All Kits:		
DESCRIPTION	PART NUMBER	QTY
Gas Valve Conversion Kit, White-Rodgers .	025-25463-000 (WR #92-0923)	1
Propane Conver. Label	035-11635-000	1
Kit Installation Instruction	035-14445-000	1
1NP0347 Kit:		
Main Burner Orifices #55 .	029-20423-055	7
1NP0348 Kit:		
Main Burner Orifices #56 .	029-20423-056	7
1NP0349 Kit:		
Main Burner Orifices #54 .	029-20423-054	7

**▲ WARNING**

*An overpressure protection device, such as a pressure regulator, which conforms to the National Fuel Gas code, ANSI Z223.1 (U.S.) or CAN-B149.1 or.2 (Canada) and acts to limit the downstream pressure to value that does not exceed 0.5 PSI (14" w.c.), must be installed in the gas piping system upstream of the furnace. Failure to do so may result in a fire or explosion or cause damage to the furnace or some of its components.*

**FURNACE CONVERSION****▲ CAUTION**

*The gas supply shall be shut off prior to disconnecting the electrical power, before proceeding with the conversion.*

1. Remove the upper access door. On 90+AFUE units, remove the burner box cover.
2. Carefully remove the wires from the gas valve and note their location so they may be properly replaced. Remove the screws that hold the manifold to the manifold brackets and slide the manifold off the burners. On 90+ AFUE units, the manifold is retained by two screws at the bottom and hooks in at the top of the burner box.
3. Remove the main burner orifices from the manifold and retain for future use.
4. Install the propane main burner orifices in the manifold and tighten them. After installing a propane orifice in each location, any leftover orifices may be discarded.
5. Reinstall the main burners in the assembly by reversing the removal process.
6. Convert the natural gas valve to propane by following instructions packed inside of the gas conversion kit envelope (025-25463-000 for White-Rodgers gas valve). Keep the original parts for future use.
7. Install the propane gas conversion label as described in the LABELS section of this instruction.
8. Refer to the unit installation instructions to complete the installation before continuing with these procedures.

**ORIFICE SIZE SELECTION**

A number of factors determine the correct orifice usage for your application. These factors include the original orifice sizing, BTU content of the gas and the altitude.

For natural gas applications, contact you gas supplier for the actual BTU content (heating value) of the fuel provided at your altitude.

Use the BTU heating value that is nearest to your value. Read across the selected table from the standard orifice to the altitude for your application and the note the new orifice size.

**EXAMPLE:** If your unit has a #56 orifice, as standard for propane, and a heating gas value of 2516 BTU/CU.FT., at an altitude of 7,000 feet, the #58 orifice will provide the correct firing rate.

For propane (LP) applications, Use Table 1 to select the proper high altitude orifice size.

**Table 1: ORIFICE PART NUMBERS**

BURNER ORIFICES	
SIZE #	SOURCE 1 PART NUMBER
Blank	029-20423-000
41	029-20423-041
42	029-20423-042
43	029-24243-043
44	029-20423-044
45	029-20423-045
46	029-20423-046
47	029-20423-047
48	029-20423-048
49	029-20423-049
50	029-20423-050
51	029-20423-051
52	029-20423-052
55	029-20423-055
56	029-20423-056
57	029-20423-057
58	029-20423-058
59	029-20423-059
60	029-20423-060

## NOX SCREEN REMOVAL (Lo-NOx Models Only)

1. Make sure that the electrical power to the unit is turned off and that the gas supply is turned off at the shutoff valve.
2. Remove the blower compartment and burner compartment access doors.
3. Disconnect the gas supply piping at the union to permit removal of the entire burner and gas control assembly from the vestibule panel. Use the wrench boss on the gas valve when removing or installing this piping.
4. Unplug the ignitor from the wire harness. Disconnect the flame sensor wires located on top of the air shield. Unplug the gas valve from the wiring harness.
5. Remove the ignitor and ignitor bracket. Handle the ignitor very carefully since it is fragile and easily broken.
6. Remove the screws holding the burner assembly to the vestibule panel. It may be necessary to remove the roll-out switch bracket(s) to gain access to one or more of these screws.
7. Remove the burner assembly. It should be possible to swing the burner assembly out of the way without disconnecting the remaining wires.
8. With the burner assembly out of the way, simply slide the NOx screens out of the heat exchanger tubes and discard the screens.
9. Replace all components in reverse order. Reconnect all wiring.

## TESTS AND ADJUSTMENTS

The following tests must be performed at the time of conversion following completion of the installation.

### CAUTION

*Make sure both gas and power supplies are shut off before proceeding*

1. Connect a manometer to the pressure tap on both the inlet and outlet side of the gas valve. Connect a power supply and a propane gas supply to the unit, if not already connected.

### CAUTION

*On 90+ AFUE models, refer to unit installation instructions for proper procedure for connecting manometer to furnace.*

2. Turn on the propane gas supply and bleed air from the gas supply lines at a point as close to the inlet or the gas valve as is practical.
3. Turn the gas valve control switch to the ON position.
4. Make sure unit electrical disconnect switch is in the OFF position.
5. Set the room thermostat to call for heat.
6. Turn unit electrical disconnect switch to ON. The combustion blower should start and the hot surface igniter should start glowing.
7. After air has been purged from the gas supply line, ignition should occur. Shortly after ignition, the manifold and gas inlet pressures can be checked on the manometers. Main burner ignition may be delayed on the first ignition cycle due to air in the gas manifold.
8. Adjust manifold pressure to 10.0" W.C. This setting will result in a propane gas input which is the same as the natural gas input found on the unit rating plate. (supply gas must be supplied to the unit at a pressure of 11-13.9" W.C.). Verify that the supply gas pressure is within the range specified above. If required, adjust the incoming regulator spring so that the pressure falls within the range.

### CAUTION

*On 90+ AFUE furnaces, the gas valve regulator cap must be in place to determine final gas pressure setting.*

9. Observe several ignition cycles. All main burners must ignite without delayed ignition or burning at the orifices. If delayed ignition is observed, verify that the igniter is properly mounted (not loose or crooked on bracket, and that bracket screws are not loose).
10. If burning at the orifices, excessive yellow tipping, or excessive noise is observed during any phase of main burner operation, verify unit operation.

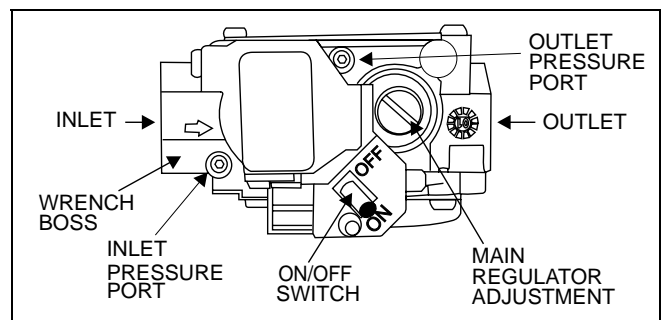
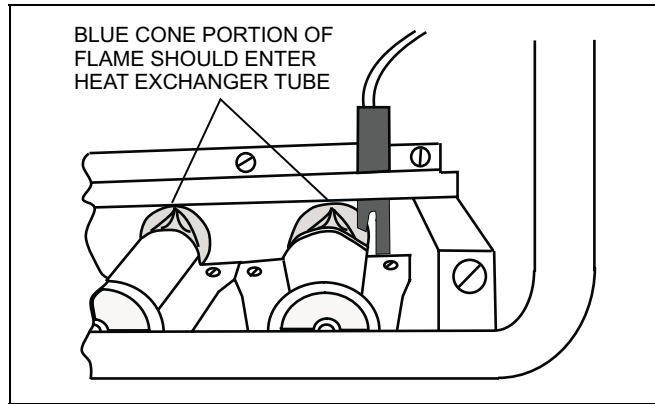

FIGURE 1 - Gas Valve

11. With the main burners ignited, check for gas leaks, especially in the following locations: gas valve inlet and outlet connections, manifold union in the burner compartment, and main burner orifices where they thread into the manifold. Repair any leaks found and recheck.

 <b>CAUTION</b>
<i>Do not use an open flame</i>

12. During Unit Operation, the main burner appearance and igniter location should be as shown below:
13. With the main burners off, disconnect the manometers and replace the plugs. Check for gas leakage at the plugs.
14. Replace all access panels.



**FIGURE 2 - Proper Burner Flame Appearance**

**Table 2: ALTITUDE/PROPANE (LP) GAS HEATING VALUE ORIFICE SECTION**

Propane Gas Heating Value (Manifold Pressure 10.0" W.C.)	Propane Orifice @ Sea Level	Recommended Orifice									
		Altitude (Ft. Above Sea Level)									
		0	2,000	3,000	4,000	5,000	6,000	7,000	8,000	9,000	10,000
2516 BTU/CU.FT	54	54	54	55	55	55	55	55	56	56	56
	55	55	55	55	55	56	56	56	56	56	57
	56	56	56	56	57	57	57	57	58	59	59

INLET GAS PRESSURE MUST BE AT 11-13.8" WC AT FURNACE. SET MANIFOLD PRESSURE AT 10.0"
--

**LABELS**

1. Remove label 035-11635-000 from the shipping box. Check the Natural Gas to Propane box.
2. Under "Rating After Conversion", write in the following:
  - a. Orifice size, as stamped on the orifice
  - b. Maximum inlet pressure
  - c. Minimum inlet pressure
  - d. Manifold pressure
  - e. Input ratings, same as on the Rating Plate
  - f. Output ratings, same as on the Rating Plate
3. Under "Changes After Conversion", write in the following:
  - a. Kit number, located on the outside of the box
  - b. Unit model number
  - c. Stamp or write in the name of the organization making conversion, address, city, state, month and year
4. Remove label backing and affix label adjacent to the Rating Plate.
5. Secure the labels furnished with each respective gas valve conversion packet.