



ITT

BEAR TRAP®

Hoffman Specialty
Installation & Maintenance
Instructions
HS-229(D)

Series 8C, 9C and 17C Balanced Pressure Thermostatic Steam Traps

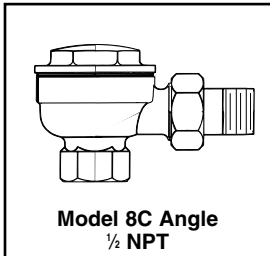

Model 8C Angle
1/2 NPT

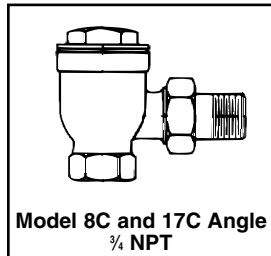

Model 8C and 17C Angle
3/4 NPT

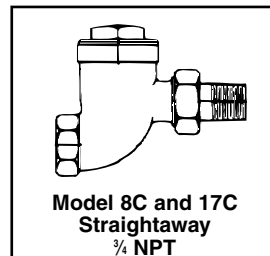

Model 8C and 17C
Straightaway
3/4 NPT

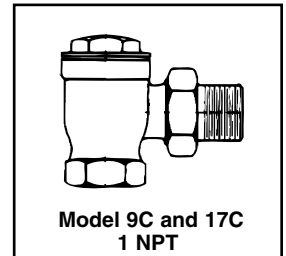

Model 9C and 17C
1 NPT

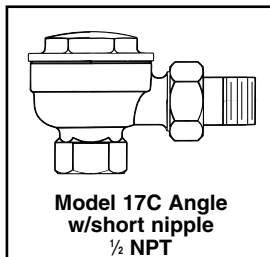

Model 17C Angle
w/short nipple
1/2 NPT

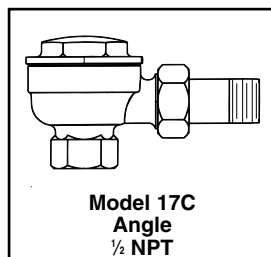

Model 17C
Angle
1/2 NPT

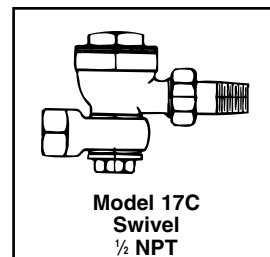

Model 17C
Swivel
1/2 NPT

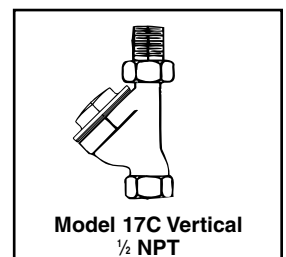

Model 17C Vertical
1/2 NPT

CAUTION

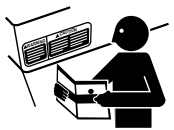

- Before using product, read and understand instructions.
- Save these instructions for future reference.

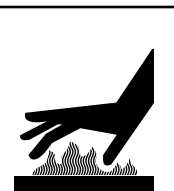

- All work must be performed by qualified personnel trained in the proper application, installation, and maintenance of steam systems in accordance with all applicable codes and ordinances.
- To prevent serious burns, wear heat resistant gloves when opening and closing steam valves, or handling hot equipment.



- To prevent serious burns, the internal pressure of the trap must be 0 psi (0 bar) before servicing.
- To prevent serious personal injury from steam pipe blow down, connect a temporary pipe between the steam pipe opening and a drain, or stand at least 100 ft. (30m) from the front of the pipe opening.

Failure to follow this caution will cause personal injury.

IMPORTANT: To prevent system damage from water hammer or sudden shock, open supply valves slowly.

If you are uncertain about the product's adaptability for your application, please call the factory or authorized representative before using the product.

The trap pressure rating must be equal or greater than the maximum system pressure.

INSTALLATION –

STEP 1 - Where to Install the Thermostatic Steam Trap

Determine where to install the thermostatic steam trap based on the following information.

- a. The trap should be located below the equipment to be drained.
- b. The trap discharge should drain by gravity into a vented return line.
- c. Allow plenty of space around the trap for servicing, which may require removal of the cap or body.

TYPICAL INSTALLATION DIAGRAMS

A. For Radiators

Radiator connections taken from up or downfeed risers

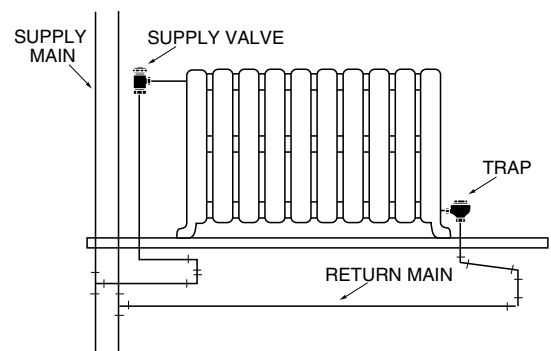
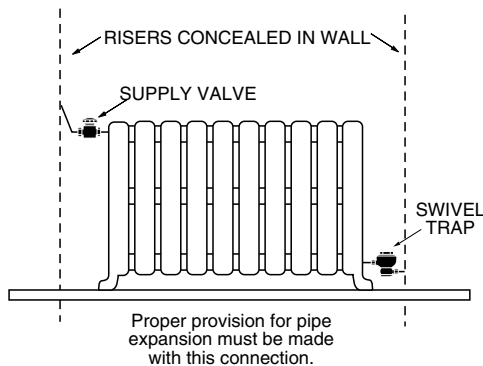

Dripping heel of downfeed riser into dry return

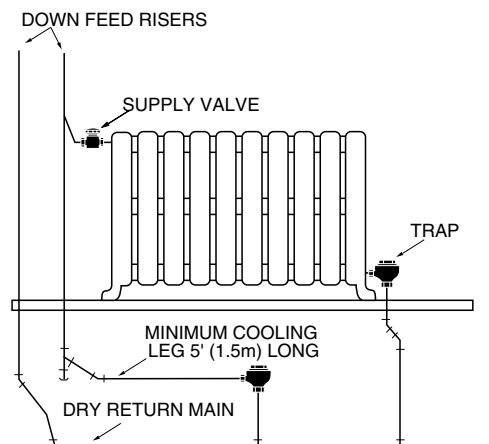

INSTALLATION –

STEP 1 - Where to Install the Thermostatic Steam Trap (cont'd)

TYPICAL INSTALLATION DIAGRAMS

A. For Radiators (cont'd)

Radiator connections from horizontal supply main into dry return

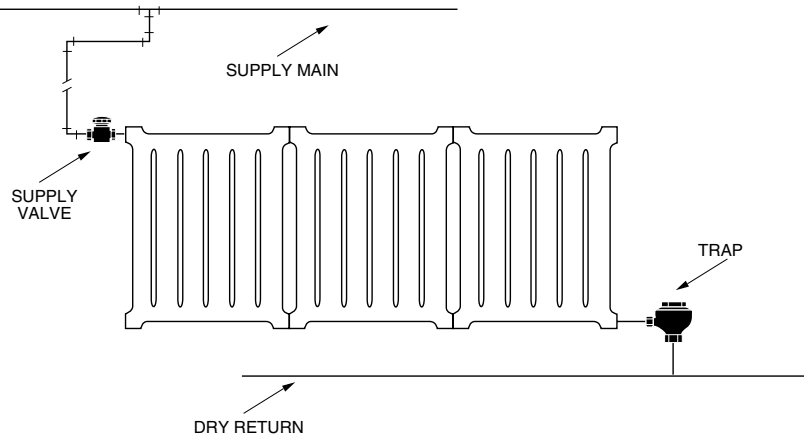

Connections to ceiling radiator located above supply and return

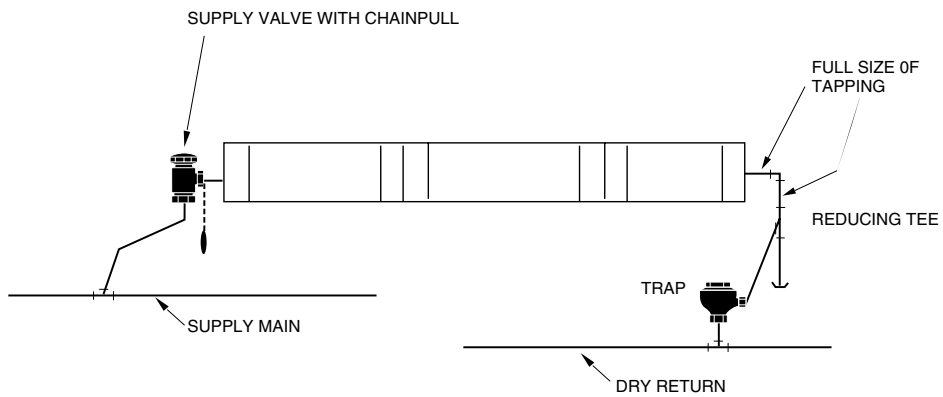

Connections to ceiling radiators with return bleed into wet return

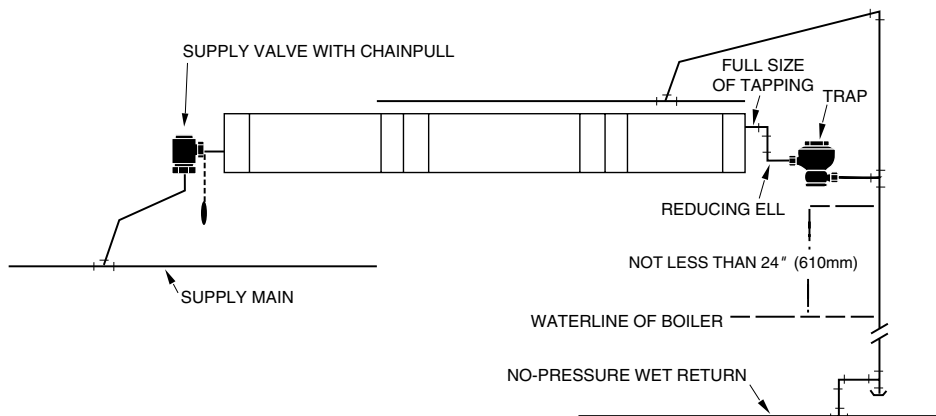

INSTALLATION –

STEP 1 - Where to Install the Thermostatic Steam Trap (cont'd)

TYPICAL INSTALLATION DIAGRAMS

B. For Steam Unit Heaters

Unit heater connections for two pipe gravity or vacuum system with supply branch dripped through trap

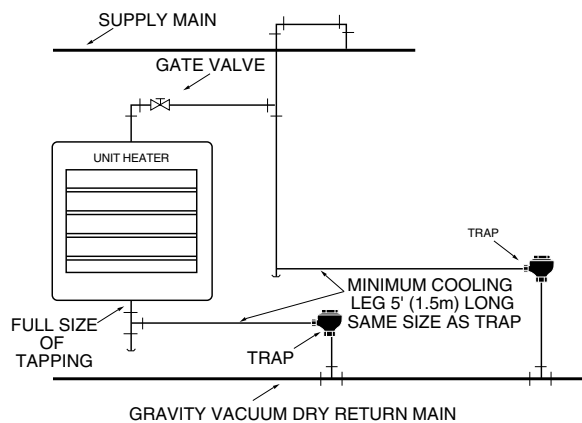

Unit heater connections for two pipe gravity or vacuum system

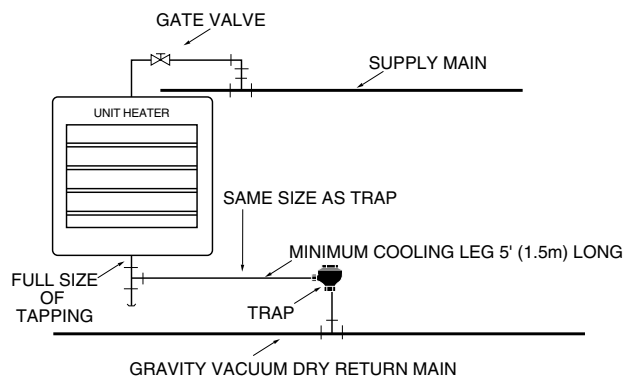

C. For Drip Traps

Dripping drop riser or end of main into dry return

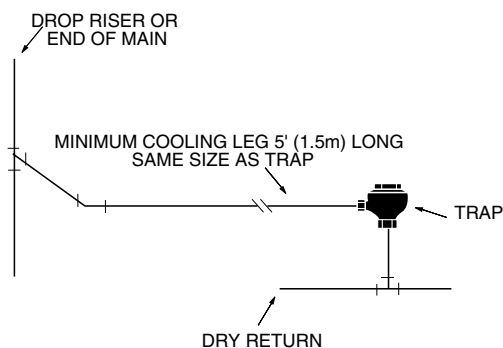

Dripping end of supply main into dry return

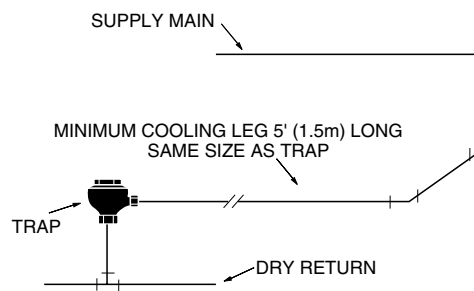

INSTALLATION –

STEP 1 - Where to Install the Thermostatic Steam Trap (cont'd)

TYPICAL INSTALLATION DIAGRAMS

D. For Convectors

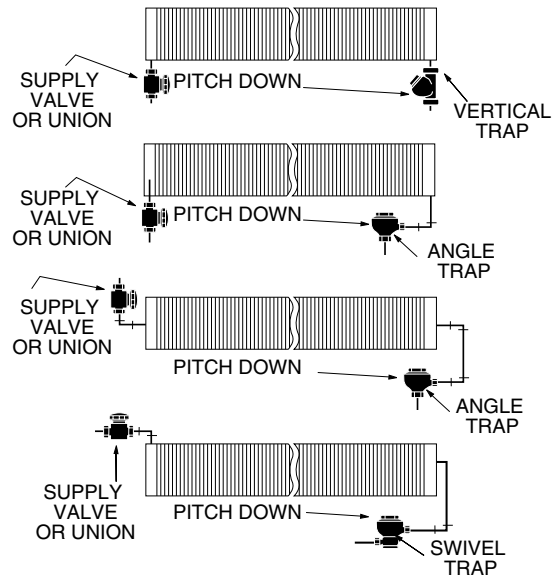

E. For Pipe Coils

Connections to header coils (not over 8 pipes)

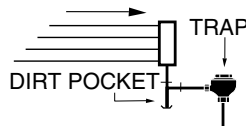

Connections to header coils (more than 8 pipes)

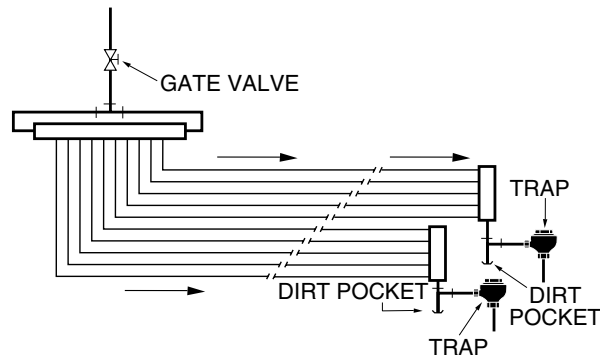

INSTALLATION –

STEP 2 - Install Trap

- a. Steam lines and equipment connected to the trap should be clean. If necessary, blow down the equipment with steam and allow it to cool before servicing, or flush with water.

	CAUTION
	To prevent serious personal injury from steam pipe blow down, connect a temporary pipe between the steam pipe opening and a drain, or stand at least 100 ft. (30m) from the front of the pipe opening.
	Failure to follow this caution will cause serious personal injury.

- b. Slide the union nut (A) over the nipple (B) so that the union nut threads (C) extend beyond the union end of the nipple (D).

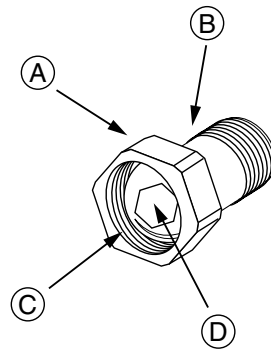

- c. Screw the nipple (B) into the equipment's condensate drain connection (E).

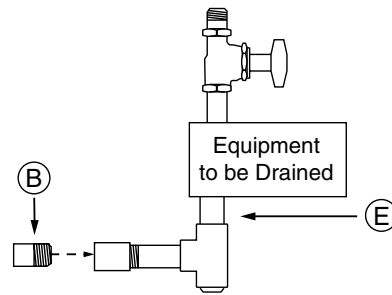

- d. Screw the nipple and union nut (F) on to the trap body (G).

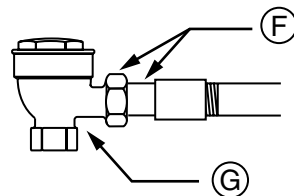

INSTALLATION –

STEP 2 - Install Trap (cont'd)

- e. Connect the trap discharge tapping (H) to the return line (J). It should be positioned so that the return line can drain by gravity.
- f. **Slowly** open the steam supply valve.

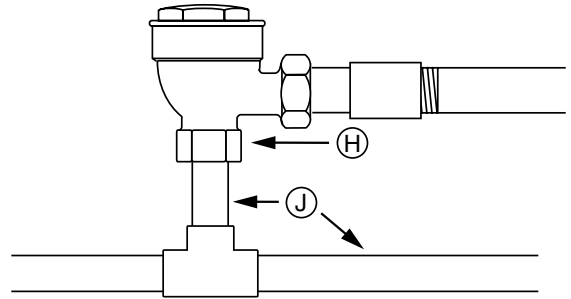

STEP 3 - Testing

- a. Inspect joints for leaks. Stop all leaks by tightening joints, if necessary

MAINTENANCE



When checked regularly and properly maintained, the Balanced Pressure Thermostatic Steam Traps will provide optimum performance and long life.

SCHEDULE:

- **Initially, every 2-3 days after start-up until system is clean.**
- **Every 6 months thereafter.**

PROCEDURE:

Test traps by following the “Troubleshooting” procedure.

	⚠ CAUTION
	<ul style="list-style-type: none">• To prevent serious burns, the internal pressure of the trap must be 0 psi (0 bar) before servicing.• To prevent serious personal injury from steam pipe blow down, connect a temporary pipe between the steam pipe opening and a drain, or stand at least 100 ft. (30m) from the front of the pipe opening. <p>Failure to follow this caution will cause personal injury.</p>



TROUBLESHOOTING

We recommend trap replacement when parts no longer operate properly. A new trap is more economical than repairing or replacing parts and it will provide greater reliability. If you choose to repair the trap, order Hoffman Specialty replacement parts and follow the Repair Procedure provided.

Problem:

1. Improper Heating

- a. **Cause:** The thermostatic element is not opening or functioning properly. This could be caused by dirt, or a broken element.

Test: Use a thermometer to test inlet temperature. A cold trap is an indication the trap failed closed.

Solution: Disassemble the trap and inspect the thermostatic assembly. Replace any worn or defective parts. Clean any dirt from trap body.

Problem:

2. Energy Wasted

- a. **Cause:** A leak in the thermostatic element caused a loss of fill in the element, which caused the element to fail open.

Test: Using a stethoscope or ultra sound device, listen for a low pitch whistle sound. A low pitch whistle sound indicates the trap is open and blowing live steam.

OR

Using a thermometer, check the trap inlet temperature. It should be at least 20°F (11°C) below the temperature in the steam space ahead of the trap.

Solution: Replace the trap or disassemble the trap and replace the thermostatic element.