

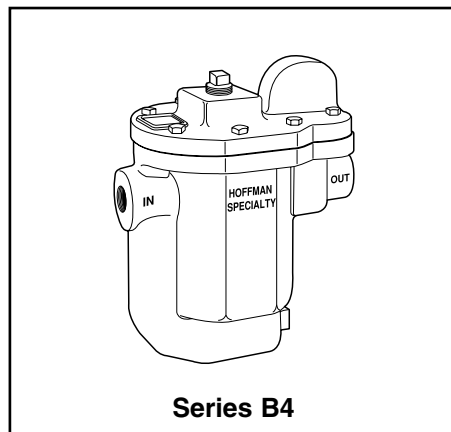

# Series B **BEAR TRAP**<sup>®</sup> Inverted Bucket Steam Traps

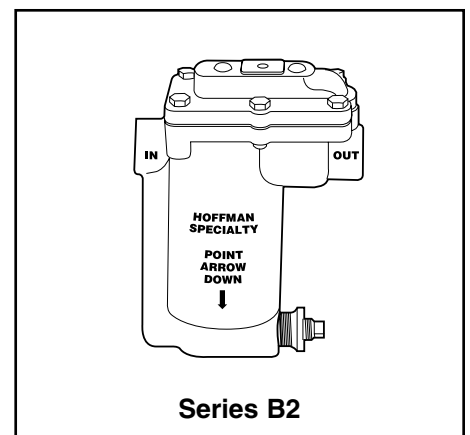
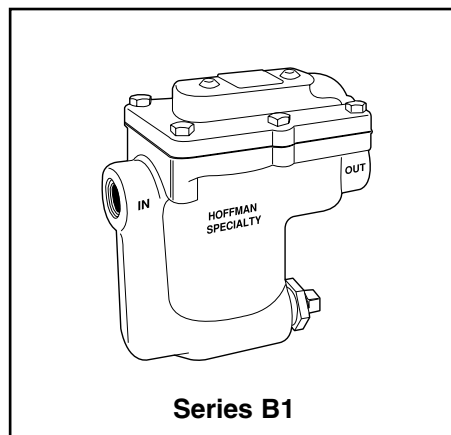
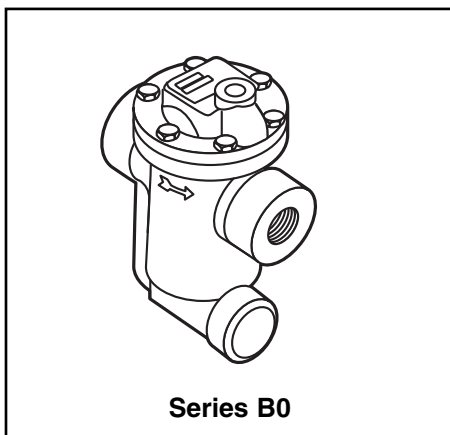

*Engineered for life*

## WARNING

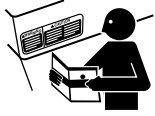

- Before using product, read and understand instructions.
- Save these instructions for future reference.



- All work must be performed by qualified personnel trained in the proper application, installation, and maintenance of steam systems in accordance with all applicable codes and ordinances.



- To prevent serious burns, wear heat resistant gloves when opening and closing steam valves, or handling hot equipment.
- To prevent serious personal injury from steam pipe blow down, connect a temporary pipe between the steampipe opening and a drain, or stand at least 100 ft. (30m) from the pipe opening.



- To prevent property damage, personal injury, or death, cap off the gate valves if they are not connected to a drain and when they are not in use for test or pressure relief.

Failure to follow this warning could cause property damage, personal injury or death.

**IMPORTANT:** To prevent system damage from water hammer or sudden shock, open supply valves slowly.

If you are uncertain about the product's adaptability for your application, please call the factory or

authorized representative before using the product.

The trap seat rating (stamped on the nameplate) must be equal to or greater than the maximum pressure differential across the trap.

# OPERATION

## BUCKET TRAP SEAT IS OPEN TO VENT AIR OR DRAIN CONDENSATE

During start-up, air is vented through the bleed hole, at the top of the bucket, into the return line.

Condensate entering the trap will flow around the bucket and drain through the open seat.

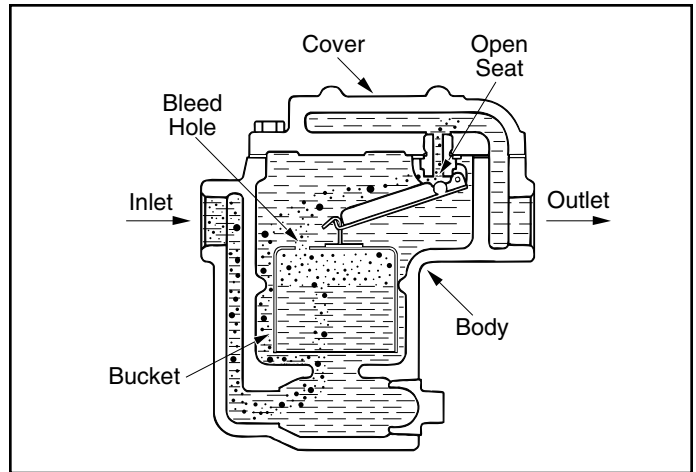

## BUCKET TRAP SEAT IS CLOSED TO RETAIN LIVE STEAM

As steam flows into the bucket trap it collects at the top of the bucket. The buoyancy of the steam raises the bucket and closes the seat. The bucket remains full of steam until more condensate enters the trap. The cycle is then repeated.

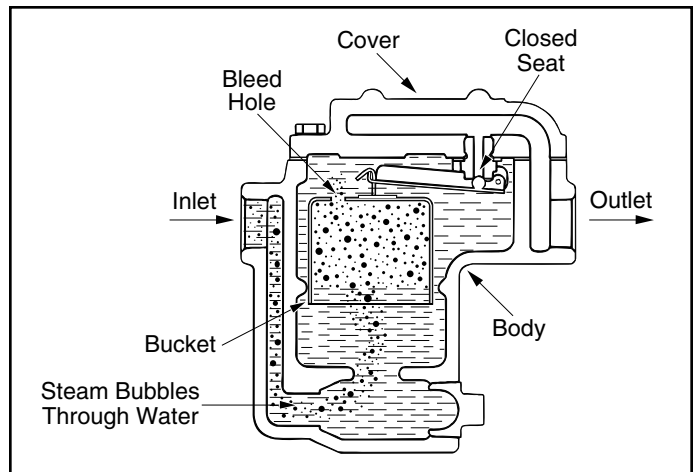

## BUCKET TRAP WITH OPTIONAL THERMAL VENT FOR FASTER AIR VENTING

Models with an optional factory installed thermal vent in the bucket allow faster air venting during start-up.

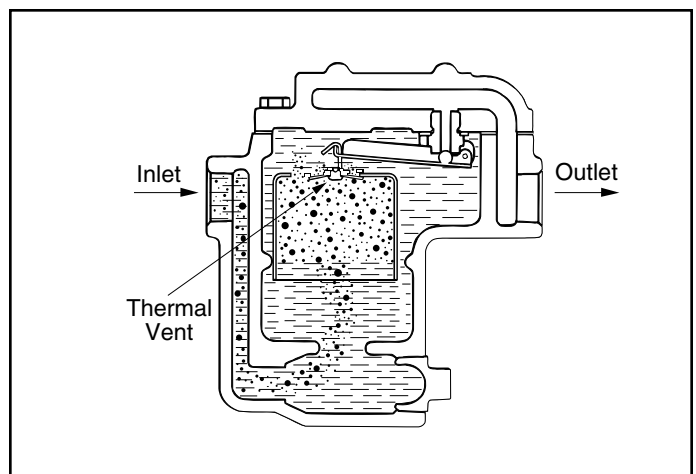

# INSTALLATION – Series B0, B1, B2, B3 & B4 Inverted Bucket Traps

1. Determine where to install the trap, based on the following requirements:
  - a. The trap must be located as close as possible and below the equipment to be drained.
  - b. The trap must be in a straight run of horizontal pipe and pitched to allow condensate to flow into the trap inlet and away from the trap outlet. Refer to the Typical Piping Diagrams at the right.
  - c. Plenty of space around the trap is needed for servicing, which may include removal of the body or cover.

## TYPICAL PIPING DIAGRAMS

### Trap Draining to Open Drain

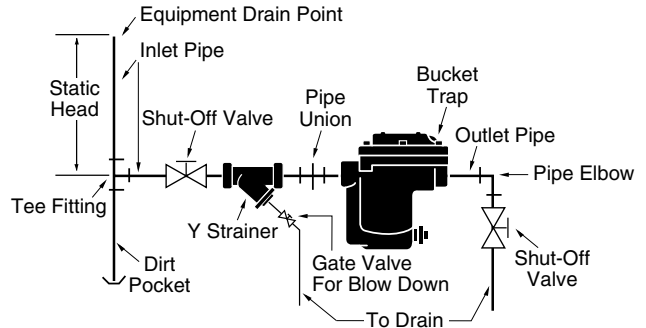

### Trap Draining to Gravity Return Line

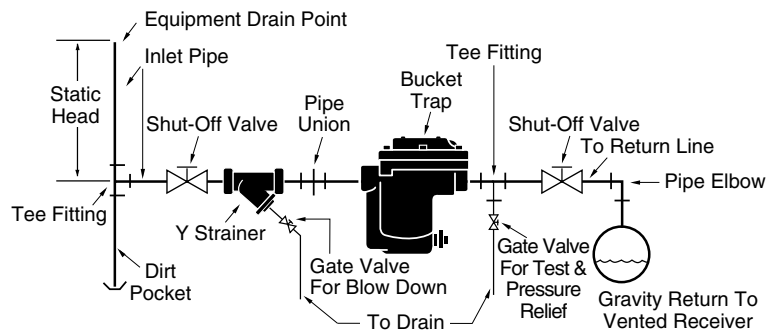

### Trap Draining to Overhead Return Line or Pressurized Return Line

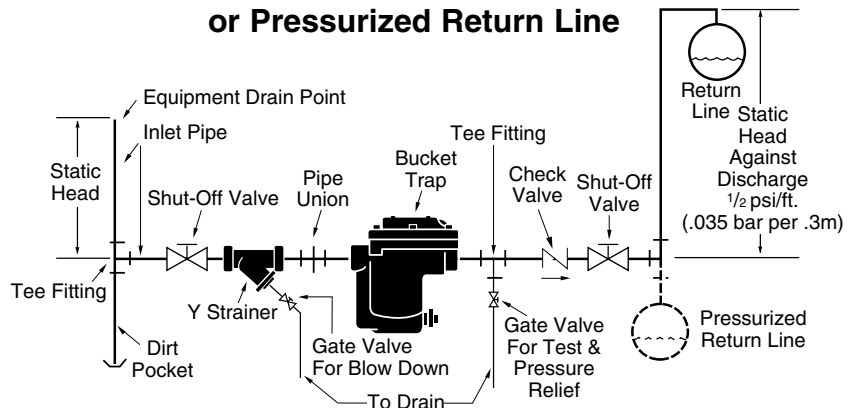

2. Install near trap piping:

- a. Install a shut-off valve (A) on the inlet pipe (B).
- b. Install a Hoffman Specialty Y Strainer (C) on the inlet pipe (B).
- c. Install a gate valve for blow down (D) by connecting it to the Y Strainer drain tapping (C).

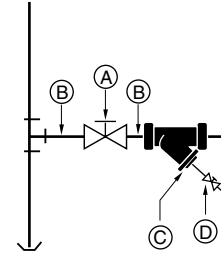

- d. Cap off the outlet pipe (X).
- e. **Slowly** turn steam on with full pressure for (5) five minutes to blow down the inlet pipe (B).
- f. Turn off steam and allow pipe to cool.
- g. Remove cap from the outlet pipe (X).

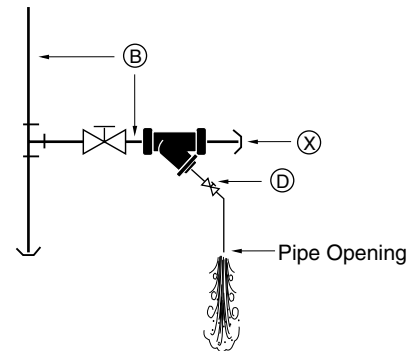

**WARNING**

To prevent serious personal injury from steam pipe blow down, connect a temporary pipe between the steam pipe opening and a drain, or stand at least 100 ft. (30m) from the pipe opening.



Failure to follow this warning could cause property damage, personal injury, or death.



**CAUTION**

To prevent serious burns, the internal pressure of the trap must be 0 psi (0 bar) before servicing.

Failure to follow this caution will cause personal injury.

- h. Close the gate valve (D). If it is not connected to a drain, install a cap (E) on the outlet pipe (F).
- Note:** Remove the cap (E) when the gate valve (D) is used for test or pressure relief. Recap when the test or pressure relief is complete.

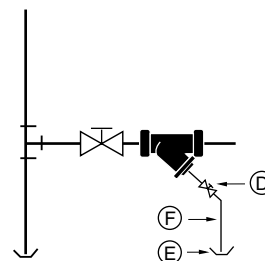

**WARNING**

To prevent property damage, personal injury, or death, cap off the gate valve if it is not connected to a drain and when it is not in use for test or pressure relief. Failure to follow this warning could cause property damage, personal injury, or death.

- i. Install a pipe union (G) on the inlet pipe (B).

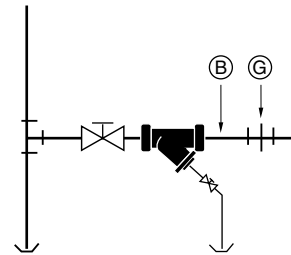

- 3. Position the bucket trap so that the cover (J) is on top and the inlet pipe (B) will connect with the "IN" tapping on the body (H).

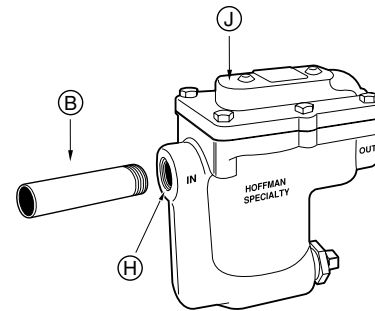

- 4. Install the bucket trap (K) on the inlet pipe (B) as positioned in Step 8.

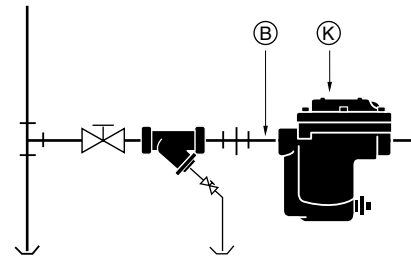

## For Applications with a Return Line

- 5. Install a tee fitting (L) on the return line (K) near the trap outlet (H).

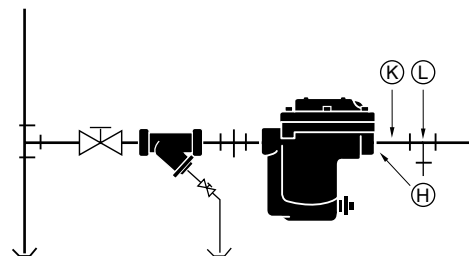

- 6a. Install a gate valve (M) on the outlet pipe (N) for test or pressure relief.
- b. Close the gate valve (M).

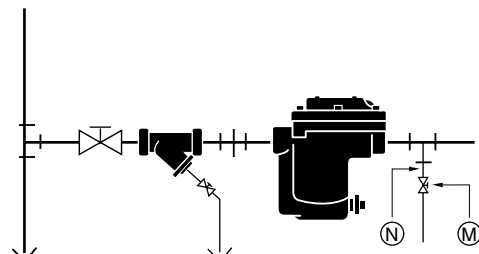

7. If the gate valve (M) is not connected to a drain, install a cap (P) on the outlet pipe (N).  
**Note:** Remove the cap (P) when the gate valve (M) is used for test or pressure relief. Recap when the test or pressure relief is complete.

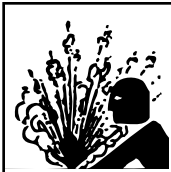
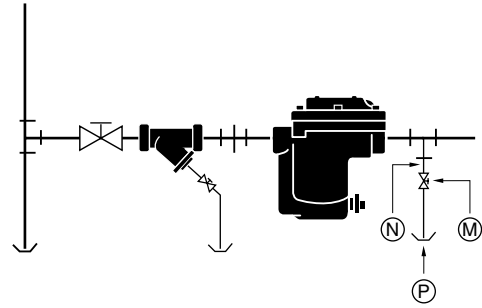

### WARNING

To prevent property damage, personal injury, or death, cap off the gate valve if it is not connected to a drain and when it is not in use for test or pressure relief. Failure to follow this warning could cause property damage, personal injury, or death.

## For Applications with a Gravity Return, Pressurized Return or Return Line Above the Trap Discharge

8. Install a check valve (R) on the return line (K).

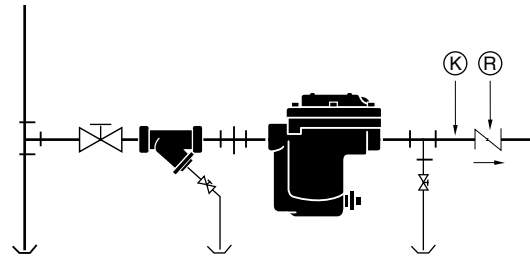

## For All Series B0, B1, B2, B3 & B4 Applications

9. Install a shut-off valve (S) on the return line (K).

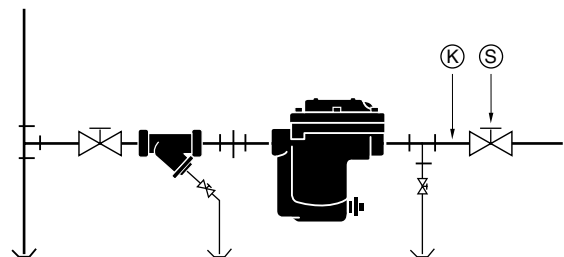

10. Depending on your application, complete one of the following steps:

a. Connect the return line (K) to a drain (T)

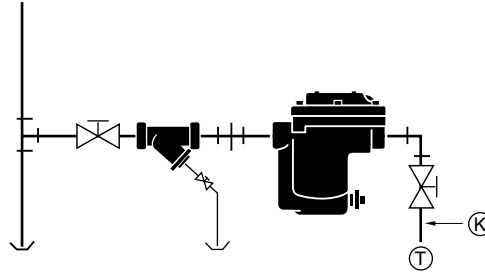

OR

b. Add a gravity return line (U)

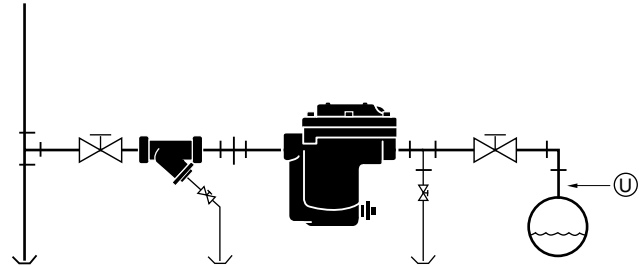

OR

c. Add a pressured return (V) or a return line above the trap discharge (W). A check valve (R) (see Step 8) must be installed for pressurized returns and return lines above trap discharge.

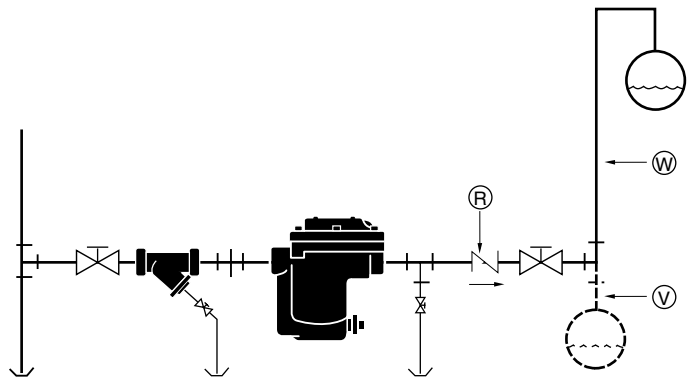

11. Prime the bucket trap as follows while the equipment is operating:

a. Close the shut-off valve (S) on the return line (K) for (1) one minute.

b. **Slowly** open the shut-off valve (S) on the return line (K).

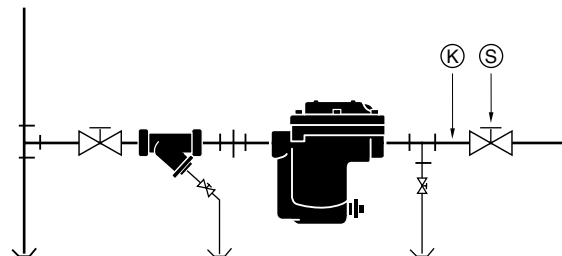

**INSTALLATION COMPLETE**



# SERIES B6 INVERTED BUCKET TRAPS

1. Determine where to install the trap, based on the following requirements:

- a. The trap must be located as close as possible and below the equipment to be drained.
- b. The trap must be in a straight run of vertical pipe. Refer to the Typical Piping Diagram at the right.
- c. Plenty of space around the trap is needed for servicing, which may include removal of the body or cover.

## TYPICAL PIPING DIAGRAM

### Trap Draining to Main Return Line Above or Below Trap Discharge

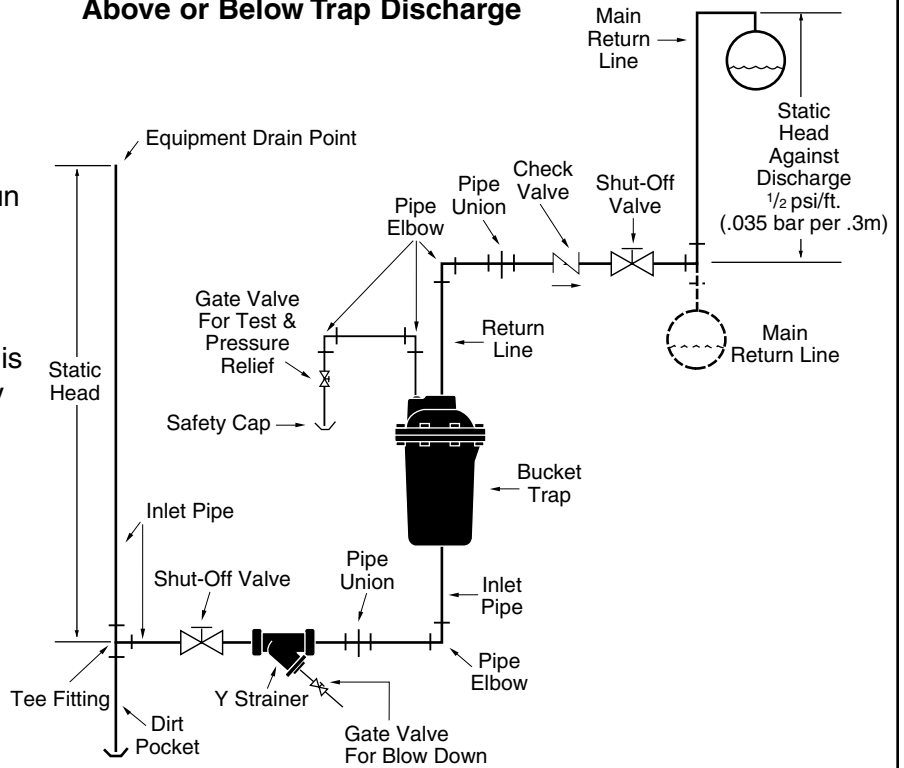

2. Install near trap piping:

- a. Install a shut-off valve (A) on the inlet pipe (B).
- b. Install a Hoffman Specialty Y Strainer (C) on the inlet pipe (B).
- c. Install a gate valve for blow down (D) by connecting it to the Y Strainer drain tapping (C).

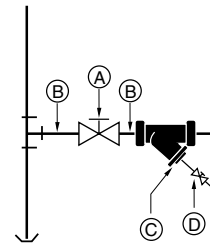

- d. Cap off the outlet pipe (X).
- e. **Slowly** turn steam on with full pressure for (5) five minutes to blow down the inlet pipe (B).
- f. Turn off steam and allow pipe to cool.
- g. Remove cap from the outlet pipe (X).

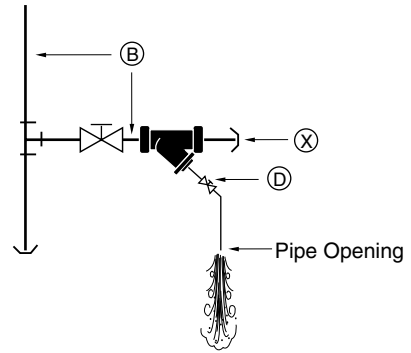

### WARNING

To prevent serious personal injury from steam pipe blow down, connect a temporary pipe between the steam pipe opening and a drain, or stand at least 100 ft. (30m) from the pipe opening.

Failure to follow this warning could cause property damage, personal injury, or death.

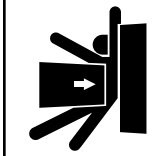

### CAUTION

To prevent serious burns, the internal pressure of the trap must be 0 psi (0 bar) before servicing.

Failure to follow this caution will cause personal injury.

- h. Close the gate valve (D). If it is not connected to a drain, install a cap (E) on the outlet pipe (F).
- Note:** Remove the cap (E) when the gate valve (D) is used for test or pressure relief. Recap when the test or pressure relief is complete.

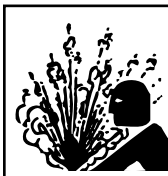
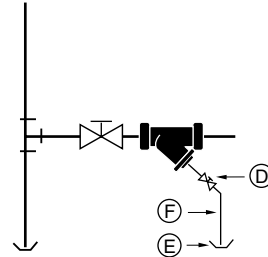

### WARNING

To prevent property damage, personal injury, or death, cap off the gate valve if it is not connected to a drain and when it is not in use for test or pressure relief.

Failure to follow this warning could cause property damage, personal injury, or death.

- i. Install a pipe union (G) on the inlet pipe (B).

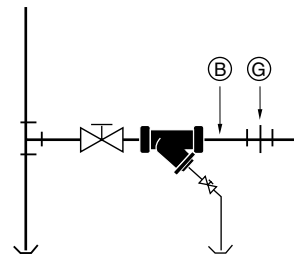

- j. Install a pipe elbow (H) on the inlet pipe (B).

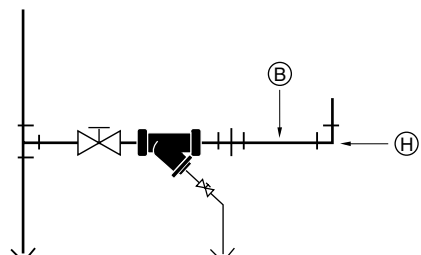

3. Position the bucket trap so that the cover (J) is on top and the inlet pipe (B) will connect with the bottom inlet tapping (K).

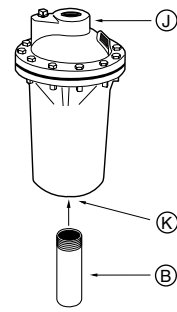

4. Install the bucket trap (L) on the inlet pipe (B) as positioned in Step 9.

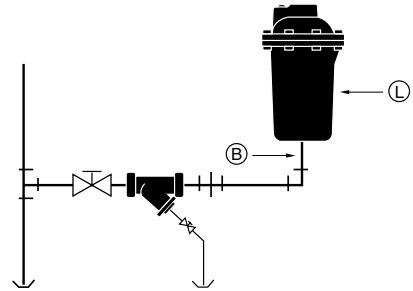

5. Remove the 1/2" (15mm) pipe lug (L) on the trap cover (J).

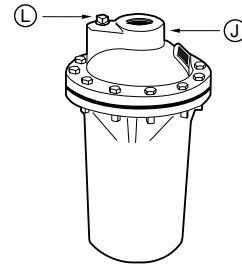

6. Connect an outlet pipe (M) on the tapping where the pipe lug was removed.

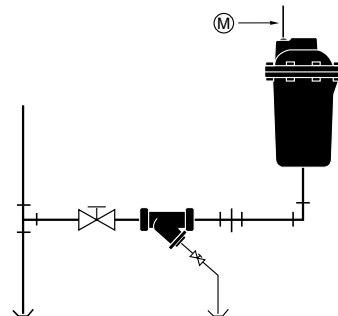

7. Install pipe elbows (N) and (P) on the outlet pipe (M).

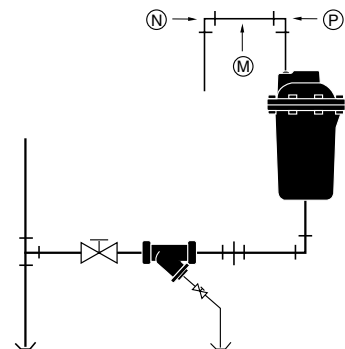

- 8a. Install a gate valve (Q) on the outlet pipe (M) for test or pressure relief.
- b. Close the gate valve (Q).

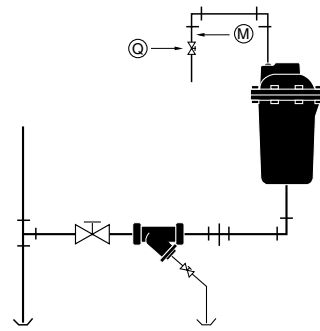

- 9. If the gate valve (Q) is not connected to a drain, install a cap (R) on the outlet pipe (M).  
**Note:** Remove the cap (R) when the gate valve (Q) is used for test or pressure relief. Recap when the test or pressure relief is complete.

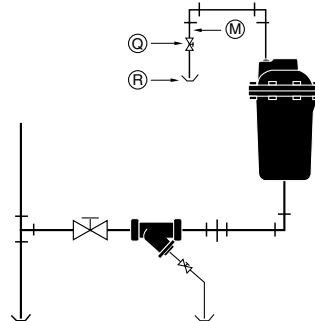

## ⚠ WARNING

To prevent property damage, personal injury, or death, cap off the gate valve if it is not connected to a drain and when it is not in use for test or pressure relief.  
 Failure to follow this warning could cause property damage, personal injury, or death.

- 10. Install a return line (S) in the trap outlet tapping (T).

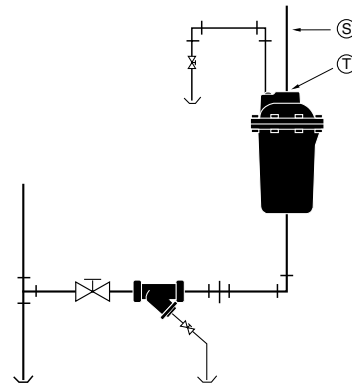

- 11. Install a pipe elbow (U) on the return line (S).

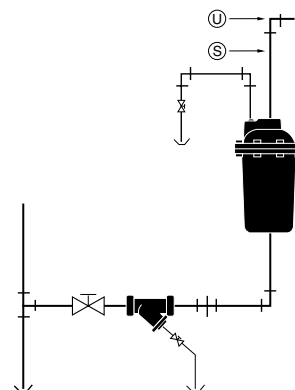

12. Install a pipe union (V) on the return line (S).

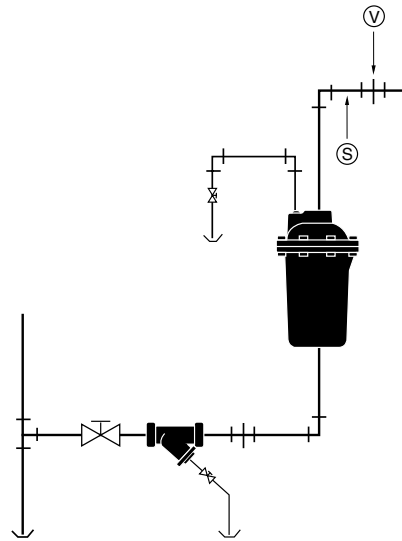

13. Install a check valve (W) on the return line (S).

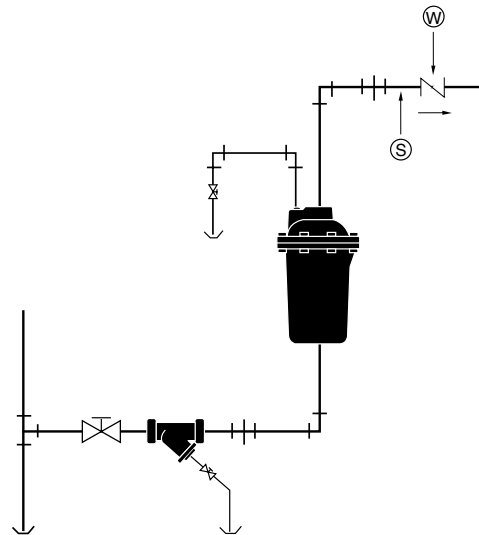

14. Install a shut-off valve (X) on the return line (S).

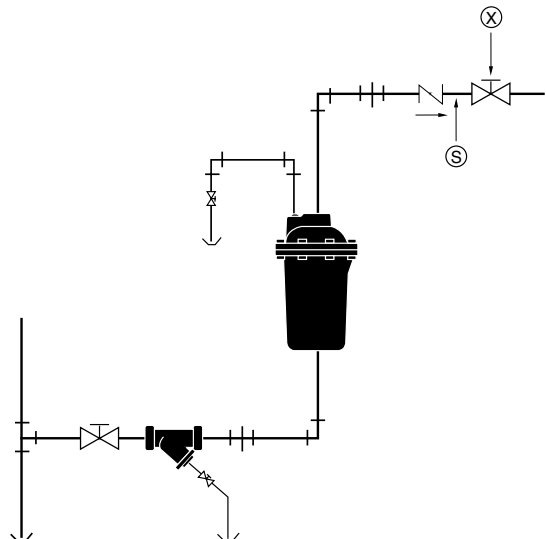

15. Depending on your application, install a pipe elbow to the trap return line (S) and connect it to:

a. A main return above the trap discharge (Y).

OR

b. A main return below the trap discharge (Z).

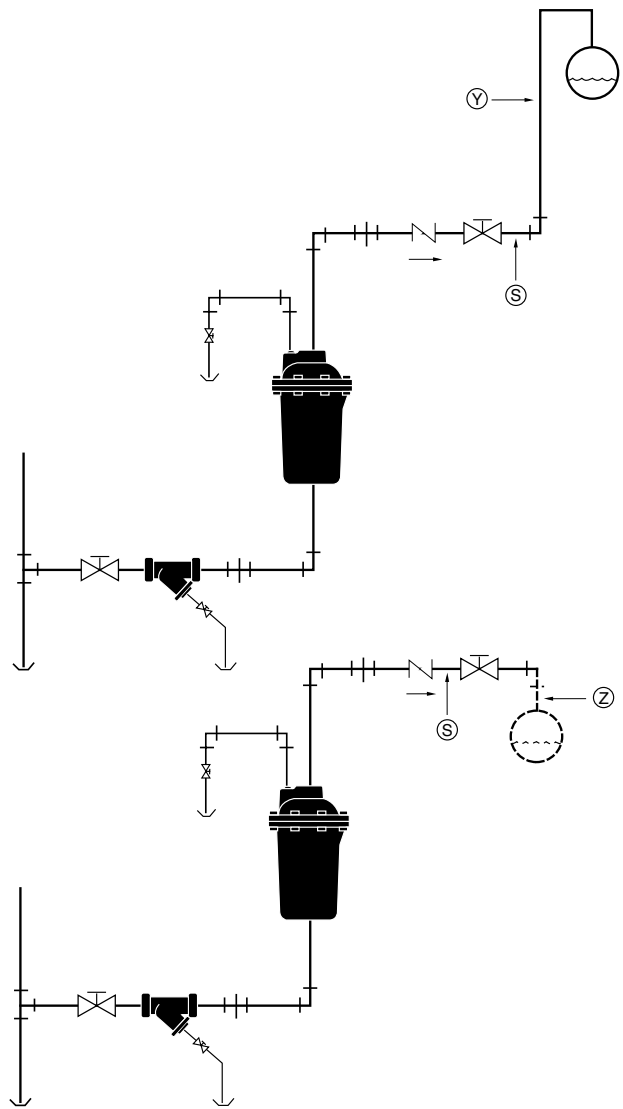

16. Prime the bucket trap as follows once the equipment is operating:

a. Close the shut-off valve (X) on the return line (S) for (1) one minute.

b. **Slowly** open the shut-off valve (X) on the return line (S).

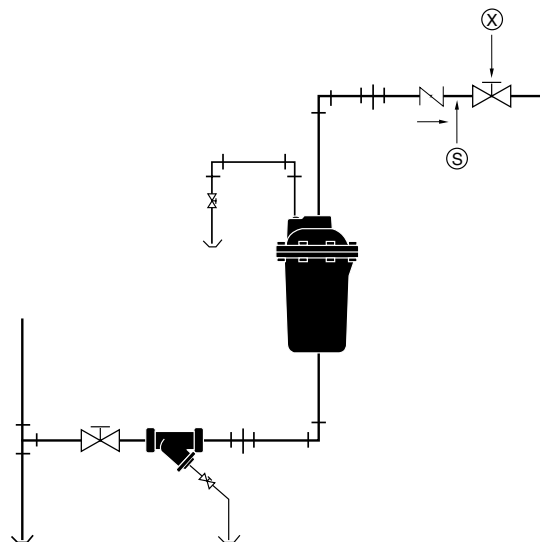

**INSTALLATION COMPLETE**

---

## MAINTENANCE

When checked regularly and properly maintained, the Series B Inverted Bucket Steam Traps will provide optimum performance and long life.

### SCHEDULE:

- **Initially, every 2-3 days after start-up until system is clean.**
- **Every 6 months thereafter.**

	<b>⚠ CAUTION</b>
	<b>To prevent serious burns, the internal pressure of the trap must be 0 psi (0 bar) before servicing.</b> <b>Failure to follow this caution will cause personal injury.</b>

1. Inspect joints for leaks. Stop all leaks by tightening bolts and replacing gaskets, if necessary.
2. Clean strainers by opening the blow down valve and allowing full steam pressure to flow out for (2) two minutes. Then, close the valve.
3. Test traps by following the “Troubleshooting” procedure.



## TROUBLESHOOTING

We recommend trap replacement when parts no longer operate properly. A new trap is more economical than repairing or replacing parts and it will provide greater

reliability. If you choose to repair the trap, order Hoffman Specialty replacement parts and follow the Repair Procedure provided.

Problem:

Problem:

### 1. Improper Heating

### 2. Energy Wasted

- a. **Cause:** The bucket bleed hole is plugged, trapping air in the top of the bucket.  
**Test:** Using a stethoscope, listen for a gurgling sound in the trap. No gurgling indicates the condensate is not draining.  
**Solution:** Disassemble the trap and unclog the bucket bleed hole.
- b. **Cause:** The steam pressure is higher than the bucket trap's seat rating pressure which prevents the trap from opening.  
**Test:** Check the seat pressure rating on the bucket trap nameplate with the available steam pressure to the equipment being drained.  
**Solution:** Install a new Hoffman Specialty Inverted Bucket Bear Trap® with the proper pressure range.  
**Note:** The trap must be selected for the maximum differential pressure that will be encountered. A high pressure seat may be used at lower differential pressures, but the capacity rating will be less than an identical size trap with a low pressure rated seat.
- c. **Cause:** Full capacity drainage is prevented by worn linkage.  
**Test:** Disassemble the trap and inspect for worn parts.  
**Solution:** Install a new Hoffman Specialty Inverted Bucket Bear Trap®.

- a. **Cause:** A worn pin and seat or dirt deposited on the seat prevents tight closure.  
**Test:** Using a stethoscope, listen for a low pitch whistle sound. A low pitch whistle sound indicates the trap is open and blowing live steam.  
**Solution:** Disassemble the trap and inspect for dirt or worn parts. Clean if dirty or install a new Hoffman Specialty Inverted Bucket Bear Trap® if worn.
- b. **Cause:** The trap does not close because the linkage detached from the bucket assembly.  
**Test:** Using a stethoscope, listen for a low pitch whistle. A low pitch whistle indicates the trap is open and blowing live steam.  
**Solution:** Disassemble the trap and inspect for worn parts. If worn, install a new Hoffman Specialty Inverted Bucket Bear Trap®.