

Installation & Maintenance Instructions

2-WAY NORMALLY CLOSED GAS VALVES

3/4", 1", 1 1/4", 1 1/2", 2", 2 1/2" OR 3" NPT — FUEL GAS SERVICE

SERIES B

V710

⚠ WARNING

To prevent the possibility of death, serious injury or property damage, the V710 Series B Gas Valve must be installed and serviced (tested) only by a qualified service technician avoiding the following hazards:

- **Electrical Hazard.** Turn off all electrical power to Hydramotor® Actuator. More than one circuit may exist.
- **Pressure Hazard.** Depressurize valve and vent hazardous or combustible fluid to a safe area before inspection or removing the valve from service.
- **Explosion/Fire Hazard.** Extinguish all open flames and avoid any type of sparking or ignition when leakage testing.

Service Notices

Except for actuator replacement or repair, V710 Series B Gas Valves are not repairable. When any performance problems are detected during routine inspection, replace valve immediately.

See separate AH Series Hydramotor® Actuator Installation and Maintenance Instructions for information on: Actuator Specifications, Installation, Positioning/Mounting, Wiring and Field Service of Actuator.

DESCRIPTION

V710 Series B Gas Valves are 2-way normally closed, soft-seated poppet-type valves for safety shutoff service on commercial or industrial gas burners. The V710 Series B was designed exclusively for use with AH Series E Hydramotor® Push-Type Actuators available in ON-OFF & LOW-HIGH-OFF positioning configurations.

The valves feature mounting flanges on the inlet and outlet of the valve. These flanges allow like valves to be mounted together in series without the use of an intermediate pipe nipple. This feature is intended for applications where two redundant valves are required by a governing body. The mounting of the two valves in series is accomplished with an optional connecting hardware kit. Please see additional instructions for the use of this kit in the Piping section of this I&M sheet.

The valves are equipped with aluminum seats and Nitrile seals. A quick-opening poppet is standard. Both overtravel seals and linear trim are available as options, i.e. *Quick Opening With Overtravel Seal, Linear Opening or Linear Opening With Overtravel Seal.*

⚠ CAUTION: Use V710 Series B Gas Valves only with natural, mixed, manufactured or liquefied petroleum (propane) gases.

ASCO Valves®

E225861-04/12

All Rights Reserved.

I&M No. V 9566 R1

Provisions for Pressure and Seat Leakage Testing

V710 Series B valves are provided with four 1/8" NPT tapped and plugged holes (pressure taps). Each side of the valve body is provided with upstream and downstream pressure taps for testing. The taps closest to the valve/actuator interface are downstream, while the taps closest to the bottom of the valve body are upstream. Leakage testing frequency shall be at least annually in accordance with NFPA-86 or original equipment manufacturer recommendations. For instructions, refer to section on *Testing for Internal (Seat) Leakage* and Figures 1 and 2.

View of valve assembly showing location of tapped and plugged holes for pressure and seat leakage testing

Pipe plugs are 1/8" NPT
(use 3/16" hex key wrench)

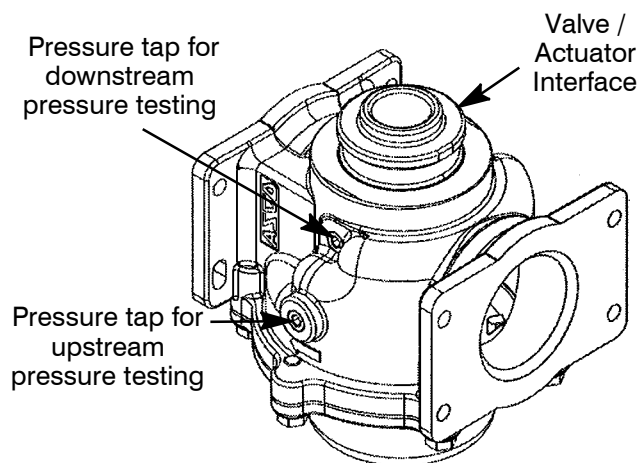

Note: Upstream and downstream pressure taps are on either side of valve body.

Figure 1. Provisions for pressure and seat leakage testing

OPERATION

V710 Series B is a normally closed, push-to-open valve which opens when the valve stem is depressed by an AH Actuator. An internal return spring closes the valve when its actuator is de-energized or removed. The actuator is retracted by its own internal return spring.

Maximum Operating Pressure Differentials:

3/4", 1", 1 1/4", 1 1/2", 2", 2 1/2" and 3" NPT – 15 psi

INSTALLATION

Check nameplate for correct catalog number, pressure, and service. Check the catalog number against Table 1 to ensure that the valve meets the requirements of the application. Never apply incompatible fluids or exceed pressure rating of the valve.

V710 SERIES B

SIZE

E = 3/4 "

F = 1 "

G = 1 1/4 "

H = 1 1/2 "

J = 2 "

K = 2 1/2 "

L = 3 "

M = 2" High Flow

SERIES REVISION LETTER

B = Revision B

BODY MATERIAL

S = Aluminum Body

OPTIONS

NONE = Quick opening (standard)

V15 = Linear trim

V22 = Quick opening plus overtravel seal

V25 = Linear plus overtravel seal

V710GBSV15 (Typical Catalog Number)

Table 1. V710 Series B Product Codification

Temperature Limitations

Ambient and Fluid Temperature: -40F (-40°C) to 150°F (65°C).

Positioning

Valve body may be mounted in any position.

CAUTION: Valve/Actuator interface has a protective cap over the stem connection, do not remove protective cap until actuator is installed on valve body.

Piping

CAUTION: Piping must comply with applicable local and national codes and ordinances, including the National Fuel Gas Code ANSI Z223.1/NFPA No. 54.

Connect piping to valve according to markings on valve body. Apply pipe compound sparingly to male pipe threads only. If applied to valve threads, the compound may enter the valve and cause operational difficulty. Avoid pipe strain by properly supporting and aligning piping. When tightening the pipe, do not use valve or solenoid as a lever. Locate wrenches applied to valve piping as close as possible to connection point. Locate wrenches applied to valve body per Figure 1. Valve should be checked for external leakage at piping connections after installation. See *Testing for External Leakage* section.

These valves feature mounting flanges on the inlet and outlet of the valve for direct connection to one another or connection in a valve train with an optional Flange Adapter Kit. The optional Flange Adapter Kit may also be used in place of direct piping for easy maintenance and disassembly of the valve without breaking any NPT pipe connections. This feature may only be used with an optional ASCO connecting hardware kit containing approved hardware and seals. The use of hardware and seals that are not part of the kit will void your warranty. Please refer to Installation & Maintenance Instructions, I&M No. V9567 for kit part numbers and contact ASCO for availability.

WARNING: To prevent the possibility of death, serious injury or property damage, only use the optional ASCO connecting hardware kit for the direct connection of these valves to one another. Complete instructions and guidelines for piping the valves together are included in the kit.

WARNING: To prevent the possibility of death, serious injury or property damage, only use ASCO brand AH Hydramotor Actuators with the V710 series of valves. The use of actuators other than ASCO brand may cause a safety issue and will void your warranty.

CAUTION: To avoid damage to the valve body DO NOT OVERTIGHTEN PIPE CONNECTIONS. If PTFE tape, paste, spray, or similar lubricant is used, use extra care when tightening due to reduced friction.

CAUTION: To protect the valve, install a strainer or filter, suitable for the service involved, in the inlet side as close to the valve as possible. Clean periodically depending on service conditions. See ASCO Series 8600 and 8601 for strainers.

Testing for External Leakage

WARNING: Explosion/Fire Hazard. To prevent the possibility of death, serious injury or property damage from the possible release of combustible gas to the atmosphere, extinguish all open flames and avoid any type of sparking or ignition.

1. Block gas flow on downstream side of valve.
2. Apply pressure to valve within nameplate rating and energize solenoid.
3. Apply a soapy solution or a commercially available leak detecting solution to the pipe connections, and/or inlet/outlet flange adapter connections and check for bubbles. If the valve has been tested for seat leakage or disassembled and reassembled for inspecting, cleaning or rebuilding, apply the solution around the solenoid base sub-assembly, bonnet/body joint and pipe plugs.
4. If leakage exists, depressurize valve and turn off electrical power supply. Tighten connections and retest following the above steps.

MAINTENANCE

Preventive Maintenance

- Prepare and follow a routine inspection schedule based on the media, environment, and frequency of use. This should include periodic internal and external leakage checks.
- Keep the medium flowing through the valve as free from dirt and foreign material as possible. Depending on medium and service conditions, clean valve strainer, filter or drip leg as required to keep the valve free of contamination. In the extreme case, contamination will cause faulty valve operation and the valve may fail to open or close.
- While in service, the valve should be operated at least once a month to ensure proper opening and closing.

Testing for Internal Seat Leakage (Refer to Figures 1&2)

⚠ WARNING: Explosion/Fire Hazard. To prevent the possibility of death, serious personal injury or property damage from the release of combustible gas to the atmosphere, extinguish all open flames and avoid any type of sparking or ignition.

⚠ CAUTION: Be sure valve can be tested without affecting other equipment.

1. Shut off both the upstream and downstream manual gas cocks. The downstream manual gas cock should remain closed throughout the entire test procedure.
2. Program the control system to operate valve through five cycles.
3. Open the upstream manual gas cock. Program the control system to energize and maintain the valve in the open (energized) position. Check all valve and piping connections for external leaks with rich soap and water solution or a commercially available leak detecting solution.
4. Shutoff the upstream manual gas cock and de-energize valve. Remove the plug from the leak test tap or downstream pressure tap in the valve body. Connect leak test equipment with the test petcock in the closed position, see Figure 2.
5. Open the upstream manual gas cock. Program the control system to energize the valve to the full open position, then immediately de-energize it to seat the valve during operation.

6. Immerse the 1/4" leak test tubing vertically into the plastic container of water to a depth of about 1/2". Slowly open the test petcock. Bubbles may appear in the water as the pressure equalizes.
7. After the rate of bubbles coming through the water stabilizes, count the number of bubbles appearing in a 10 second period. The allowable leakage in 10 seconds for an orifice diameter of 1 inch (25.4 mm) or less is 6 bubbles (3 cc/min). For valves with an orifice diameter over 1 inch (25.4 mm) the allowable leakage rate is 6 bubbles (3 cc/min.) per inch (25.4 mm) of orifice diameter. If leakage exceeds this rate, replace valve.

NOTE: The leakage rate above recognizes that some wear and contamination from use can result in a slight amount of leakage. The allowable leakage rate is well within the leakage limits as recognized by applicable approval agencies.

8. Close the upstream manual gas cock and the test petcock. Then remove the test equipment. Apply a small amount of Loctite Corporation's PST® Pipe Sealant 567 (or equivalent) to the pipe plug threads. Reinstall pipe plug and torque to 12 ft-lbs (16.3 Nm).
9. Open the upstream manual gas cock. Program the control system to energize and maintain the valve in the open (energized) position. Check 1/4" NPT pipe plug connection for external leaks with rich soap and water solution or a commercially available leak detecting solution.
10. De-energize the valve. Open the downstream manual gas cock.
11. Restore the system to normal operation.

