



**6 Series
Pressure Switch**

Type J6



UNITED ELECTRIC
CONTROLS
**Installation and Maintenance
Instructions**

Please read all instructional literature carefully and thoroughly before starting. Refer to the final page for the listing of Recommended Practices, Liabilities and Warranties.

GENERAL

 BEFORE INSTALLING, CHECK THE SENSOR MODEL SELECTED FOR COMPATIBILITY TO THE PROCESS MEDIA IN CONTACT WITH THE SENSOR AND WETTED PARTS.

J6 pressure switches are activated when a bellows or piston sensor responds to a pressure change. This response actuates a single snap-action switch, converting the pressure signal into an electrical signal.

Set point may be varied by turning the internal adjustment screw according to procedures outlined below. (See Part II – Adjustments).

Please refer to product bulletin for product specifications. UE product bulletins may be found at www.ueonline.com

On models supplied with an external manual reset button, be sure to leave sufficient finger space over the reset button for the operator to reset the switch.

WIRING

 WIRE IN ACCORDANCE WITH LOCAL OR NATIONAL CODES. BE SURE ALL LIVE SUPPLY CIRCUITS ARE DISCONNECTED BEFORE WIRING THE CONTROL. MAXIMUM WIRE SIZE #14 AWG.

Remove the four screws retaining the cover and cover gasket. A 1/2" NPT conduit connection is provided on the upper left hand side of the enclosure. The three switch terminals are clearly labeled common, normally open and normally closed.

If lead wires are supplied, color coding is as follows:

	SPDT
Common	Violet
Normally Open	Blue
Normally Closed	Black

A threaded grounding boss, tapped #10-32, is provided in the lower left corner of the enclosure. Keep the wires as short as possible to prevent interference with the plunger, manual reset button and, when provided, the adjustable differential switch wheel.

Part I - Installation

Tools Needed

- Adjustable wrench
- Flatblade screwdriver

MOUNTING

J6 pressure switches may be mounted and operated in any position. They may be surface mounted via the two mounting ears on either side of the enclosure, or mounted directly to a rigid pipe by using the pressure connection.

 LOCATE THE UNIT WHERE VIBRATION, SHOCK AND AMBIENT TEMPERATURE CHANGES ARE MINIMAL. SHOULD THE UNIT BE INSTALLED WHERE CONDENSATION IS EXPECTED, VERTICAL MOUNTING IS RECOMMENDED.

 NEVER USE THE ENCLOSURE FOR LEVERAGE TO HAND TIGHTEN THE PRESSURE CONNECTION. ALWAYS USE A WRENCH TO TIGHTEN THE PRESSURE CONNECTION TO THE PIPE.

Part II - Adjustments

Tools Needed

Models 126, 134, S126B, S134B: 3/16" & 1/4" open-end wrenches

Models 136-160, S136B, S160B, 680: 5/8" open-end wrench

Models 258-274, 354-364: 11/16" open-end wrench

Models 218-230: 1/4" open-end wrench

Models 610-614: 3/16" open-end wrench

Pressure Models

For set point adjustment, connect unit to a calibrated pressure source. Remove cover and gasketing. The adjusting screw, labeled "A" in Figures 1 & 2, is located beneath the switch and is turned to adjust the set point. Using the appropriately sized open-end wrench (see Tools Needed above), turn the adjustment screw towards the left (clockwise) to increase set point or towards the right (counter-clockwise) to decrease set point.

Vacuum Models

For set point adjustment, connect unit to a calibrated source. Remove cover and gasketing. The adjusting screw, labeled "A" in Figures 1 & 2, is located beneath the switch and is turned to adjust the set point. Using a 1/4" open-end wrench, turn the adjustment screw towards the right (counter-clockwise) to increase set point (towards full vacuum) or towards the left (clockwise) to decrease set point (towards 0 psig).

NOTE: For models 126-134 & S126B-S134B, use 3/16" open-end wrench to keep item B (Figure 2) from turning.

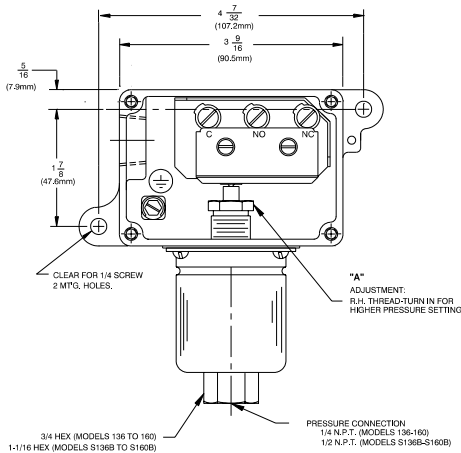

Figure 1: Models 136-160, S136B-S160B, 258-274, and 354-364

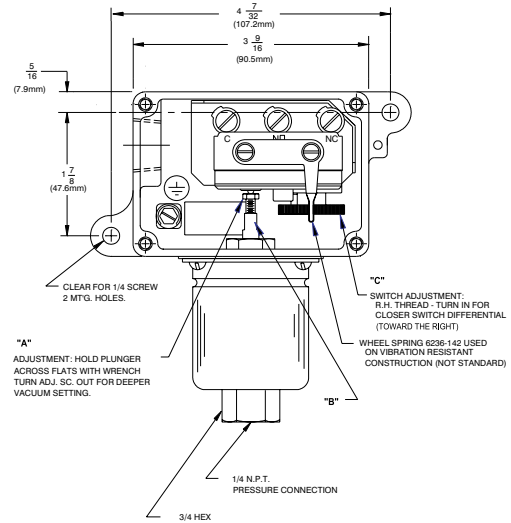

Figure 2: Models 126, 134, S126B, S134B, 218-230, 610-614, 680

NOTE: Picture shows adjustable deadband switch option

Adjustable Deadband Switch, (Option 1520)

Units with this option are equipped with a special snap switch that allows the deadband to be manually adjusted. Turning this wheel raises or lowers the pressure rise set point. The fall set point remains constant. Consult factory for additional information. (Item C in Fig. 2)

Manual Reset Switches, 1530 Option

Units with this option incorporate a snap switch that, when activated, remains tripped until the pressure drops and the reset button (located on top of the enclosure) is manually depressed to reset the switch.

Replace cover when all operations are complete and before using.

Dimensions

Dimensional drawings for all models may be found at www.ueonline.com.

Dimension A

Models	Inches	mm	NPT
126-160	5.06	128,5	1/4
S126B-S160B	5.40	139,7	1/2
218-230	4.31	109,5	1/4
258-274	4.75	120,7	1/4
354-364	4.80	121,9	1/4
610-614	5.70	144,8	1/4
680	4.95	125,7	1/4

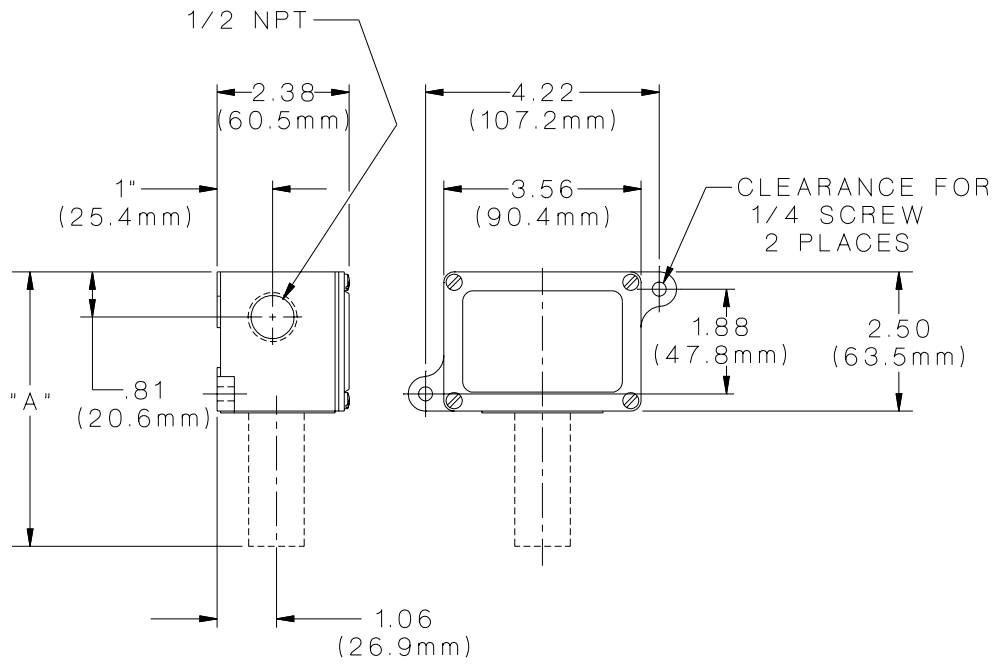

Pressure Connections

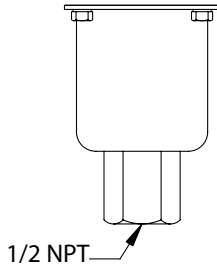

Models S1261B-S160B

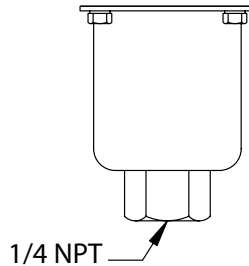

Models 126-160

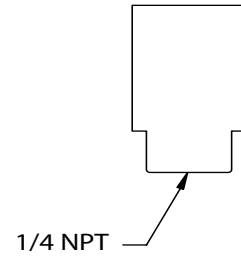

Models 218-230

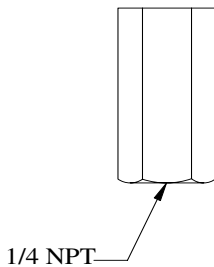

Models 258-274

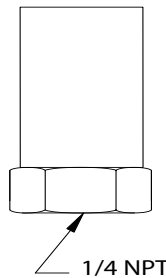

Models 354-364, 680

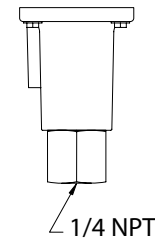

Models 610-614

RECOMMENDED PRACTICES AND WARNINGS

United Electric Controls Company recommends careful consideration of the following factors when specifying and installing UE pressure and temperature units. Before installing a unit, the Installation and Maintenance instructions provided with unit must be read and understood.

- To avoid damaging unit, proof pressure and maximum temperature limits stated in literature and on nameplates must never be exceeded, even by surges in the system. Operation of the unit up to maximum pressure or temperature is acceptable on a limited basis (e.g., start-up, testing) but continuous operation must be restricted to the designated adjustable range. Excessive cycling at maximum pressure or temperature limits could reduce sensor life.
- A back-up unit is necessary for applications where damage to a primary unit could endanger life, limb or property. A high or low limit switch is necessary for applications where a dangerous runaway condition could result.
- The adjustable range must be selected so that incorrect, inadvertent or malicious setting at any range point cannot result in an unsafe system condition.
- Install unit where shock, vibration and ambient temperature fluctuations will not damage unit or affect operation. When applicable, orient unit so that moisture does not enter the enclosure via the electrical connection. When appropriate, this entry point should be sealed to prevent moisture entry.
- Unit must not be altered or modified after shipment. Consult UE if modification is necessary.
- Monitor operation to observe warning signs of possible damage to unit, such as drift in set point or faulty display. Check unit immediately.
- Preventative maintenance and periodic testing is necessary for critical applications where damage could endanger property or personnel.
- Electrical ratings stated in literature and on nameplate must not be exceeded. Overload on a switch can cause damage, even on the first cycle. Wire unit according to local and national electrical codes, using wire size recommended in installation sheet.
- Do not mount unit in ambient temp. exceeding published limits.

LIMITED WARRANTY

Seller warrants that the product hereby purchased is, upon delivery, free from defects in material and workmanship and that any such product which is found to be defective in such workmanship or material will be repaired or replaced by Seller (Ex-works, Factory, Watertown, Massachusetts. INCOTERMS); provided, however, that this warranty applies only to equipment found to be so defective within a period of 24 months from the date of manufacture by the Seller. Seller shall not be obligated under this warranty for alleged defects which examination discloses are due to tampering, misuse, neglect, improper storage, and in any case where products are disassembled by anyone other than authorized Seller's representatives. EXCEPT FOR THE LIMITED WARRANTY OF REPAIR AND REPLACEMENT STATED ABOVE, SELLER DISCLAIMS ALL WARRANTIES WHATSOEVER WITH RESPECT TO THE PRODUCT, INCLUDING ALL IMPLIED WARRANTIES OF MERCHANTABILITY OR FITNESS FOR ANY PARTICULAR PURPOSE.

LIMITATION OF SELLER'S LIABILITY

SELLER'S LIABILITY TO BUYER FOR ANY LOSS OR CLAIM, INCLUDING LIABILITY INCURRED IN CONNECTION WITH (I) BREACH OF ANY WARRANTY WHATSOEVER, EXPRESSED OR IMPLIED, (II) A BREACH OF CONTRACT, (III) A NEGLIGENCE ACT OR ACTS (OR NEGLIGENT FAILURE TO ACT) COMMITTED BY SELLER, OR (IV) AN ACT FOR WHICH STRICT LIABILITY WILL BE INPUTTED TO SELLER, IS LIMITED TO THE "LIMITED WARRANTY" OF REPAIR AND/OR REPLACEMENT AS SO STATED IN OUR WARRANTY OF PRODUCT. IN NO EVENT SHALL THE SELLER BE LIABLE FOR ANY SPECIAL, INDIRECT, CONSEQUENTIAL OR OTHER DAMAGES OF A LIKE GENERAL NATURE, INCLUDING, WITHOUT LIMITATION, LOSS OF PROFITS OR PRODUCTION, OR LOSS OR EXPENSES OF ANY NATURE INCURRED BY THE BUYER OR ANY THIRD PARTY.

UE specifications subject to change without notice.



**UNITED ELECTRIC
CONTROLS**

P.O. Box 9143, Watertown, MA 02471-9143 USA

617 926-1000 Fax 617 926-2568

<http://www.ueonline.com>