



ISO 9001



UL recognized  
FM approved

## Automatic Valve Proving Control

## LDU11



### Features

- Performs leak test of the gas shut-off valves before start-up and/or immediately after burner shut-down
- No inlet gas pressure limitations
- Easy-to-read dial indicates progress of test program
- Ability to eliminate or leak test the vent valve
- Cost effective control improves system safety
- Globally Approved – cULus, FM, CE

### Application

The LDU11... control detects leakage of the shut-off valves on gas trains with two safety shutoff valves. During each burner cycle, the LDU control unit automatically sequences, and if a leak is detected, initiates a lockout and prevents the burner from starting up.

### Function

The LDU11 (or control unit) is used in a gas-fired combustion system with or without a vent valve in the gas train.

Installed with one or two pressure switches mounted between the gas valves, the LDU automatically initiates gas valve proving either

- prior to burner start-up
- immediately after the controlled shutdown, or
- both prior to burner start-up and immediately after shutdown

The valve leak test is completed in two stages:

- First test phase «Test1», evacuates the pressure between the gas valves to test the upstream gas shutoff valve. The pipe between the gas valves is monitored by a leak detect pressure switch for no increase in pressure.
- Second test phase «Test2», pressurizes the area between the gas valves to test the downstream safety shutoff valve. The pipe between the gas valves is monitored by the leak detect pressure switch for no decrease in pressure.

If the leak detect switch signals excessive gas pressure increase during the first test phase «Test1», or decrease during the second test phase «Test2», the LDU control will lockout and prevent burner start-up. The indicator dial on the front of the unit indicates the progress of the leak test. When a fault occurs, the indicator dial stops at the time of lockout, and indicates which of the valves is leaking. In the event of a lockout, the reset button on the front of the control will light orange to indicate a fault.

Pushing the clear window in front of the indicator dial once will reset the LDU control. DO NOT hold in the reset button. The LDU may also be reset with a remote button (see wiring diagram).

## Ordering

---

**Control unit for gas valve proving, without plug-in base**

- For AC 220...240 V, 50...60 Hz
- For AC 100...110 V, 50...60 Hz

**LDU11.523A27**

**LDU11.523A17**



**Plug-in base**

**AGM11**

The following items must be ordered **separately**:

- (1) or (2) single-pole, double throw pressure switches. See bulletin 155-292 for Siemens QP... Series pressure switch selections.

## Warning Notes

---

- **All regulations and standards applicable to the particular application must be observed!**
- **Qualified personnel must always carry out installation and commissioning work!**
- **The electrical wiring must be made in compliance with national and local standards and regulations!**
- **The LDU... must be completely isolated from the mains before performing any wiring!**
- **Secure the LDU to the base plate to ensure protection against electric shock!**
- **Check wiring and all safety functions.**
- **Do not open or modify the control.**
- **Fall or shock can adversely affect the control. Do not put such units into operation, even if they do not exhibit any damage.**

## Mounting notes

---

The LDU control must be mounted in an enclosure, typically in the control panel containing the flame safeguard. There are no distance restrictions from the gas train. The LDU control is not adversely affected by electromagnetic resonance caused by items such as ignition transformers.

One or two automatic reset single-pole, double-throw pressure switches must be mounted in between the gas safety shutoff valves. Manual reset switches are not permitted to be the leak detection switch. No additional piping modifications are required to the gas train.

## Mechanical design

---

The LDU control includes:

- The synchronous motor with its gear train and step action sequence switch
- The camshaft with its 15 nonadjustable cams
- The program indicator at the head of the camshaft
- One main and one auxiliary relay
- The lockout relay which can be electrically reset from a remote location
- The unit fuse and a spare fuse

The plug-in base carries the following terminals:

- 24 connection terminals
- 3 earth terminals
- 3 neutral terminals, prewired to terminal 2 (neutral input)

The front dial provides information about the program sequence, the type of fault and the point in time the fault occurred, using easy-to-remember symbols.

### Technical data

---

#### General unit data

Mains voltage	
- LDU11.523A17	AC 100 V –15 %...AC 110 V +10 %
- LDU11.523A27	AC 220 V –15 %...AC 240 V +10 %
Mains frequency	50...60 Hz ±6 %
Power consumption	
- During the test	3.5 VA
- During operation	2.5 VA
Primary fuse (external)	T10 / 500V
Unit fuse	T6.3H250V to IEC 127
Perm. input current at terminal 1	5 A
Perm. Current rating of control terminals	4 A
Required switching capacity of pressure switch	min. 1 A, AC 250 V
Mounting	In a panel or control cabinet
Mounting orientation	No restrictions
Degree of protection	NEMA 1, 2, 5, 12, 13
Weight	
- LDU11...	4 lbs
- Plug-in base	½ lb

#### Environmental conditions

<b>Transport</b>	
Temperature range	-58...+140 °F
<b>Operation</b>	
Temperature range	-5...+140 °F

#### Approvals (110 V only):

FM	J.I. 1Z2A6.AF Dec 1995
cULus	File MH26883
CSA	In Progress

#### Approvals (110 V and 220 V):

CE Electromagnetic compatibility EMC	89 / 336 EEC incl. 92 / 31 EEC
CE Directive for gas appliances	90 / 396 EEC

---

The LDU monitors the automatic reset, leak detect pressure switch between the gas valves. During the first test phase, called «Test1», the downstream gas valve is powered for 4 seconds, providing atmospheric pressure between the valves being tested. If the upstream gas valve is leaking, causing the pressure to rise above the set point of the leak detect switch, the LDU will initiate a lockout and trigger an alarm (optional). The program indicator then stops at «Test1» to indicate the upstream gas valve is leaking. If no leak is detected in the upstream gas valve, the LDU control continues its program with the second test phase.

During the final test phase, «test 2», the upstream gas valve is powered for 4 seconds, pressurizing the area between the gas valves. During this test, the pressure between the gas valves may not decrease below the set point of the pressure switch. If pressure falls below the set point, the LDU control will initiate lockout and prevent the burner from starting up. The program indicator on the front dial then stops at «Test2» to indicate the downstream gas valve is leaking.

On successful completion of the second test phase, the control unit closes dual internal relays to complete the internal control loop between terminals 3 and 6. The LDU recycles to the start position for the next test. During these steps, the positions of the control contacts remain unchanged. If a lockout occurs, terminal 13 is powered and may be wired to an external alarm.

### LDU Sequence of operations, 60 Hertz

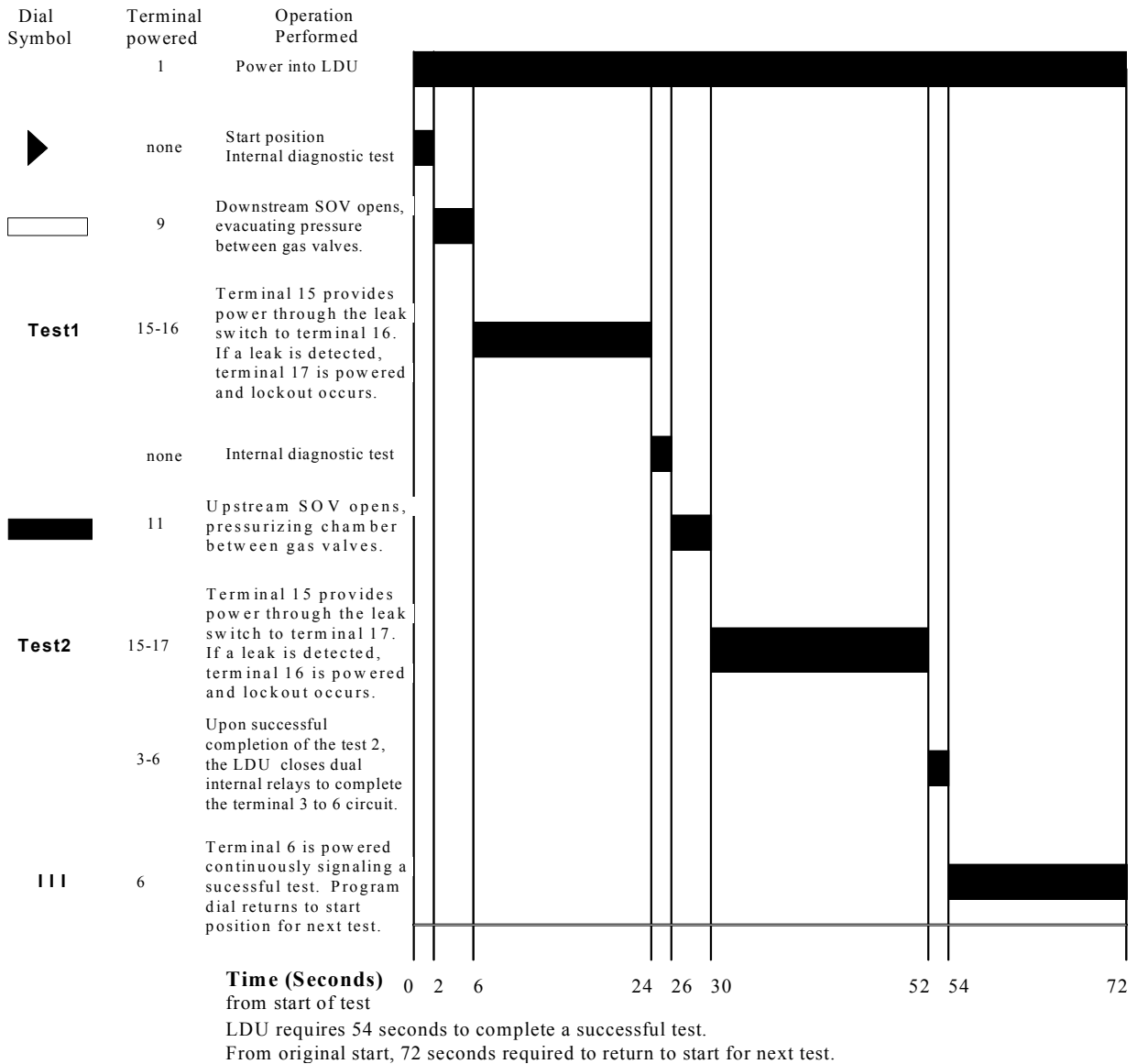



## Wiring and setting of LDU... Single Leak Detection Pressure Switch:

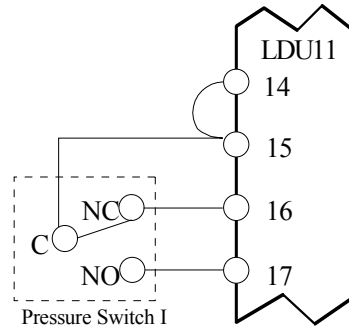

During Test 1, power is on Terminal 15. After the area between the gas valves has been evacuated of pressure, the switch should have power through terminal 15 to terminal 16. If the main gas valve is leaking, the area between the gas valves fills with gas, leak detection pressure switch I trips, sending power to terminal 17, causing a lockout.

During Test 2, Terminal 15 is powered, and with pressure between the gas valves, terminal 17 will also be powered. If the blocking gas valve is leaking, the area between the gas valves loses pressure. Leak detection pressure switch I trips, power is sent to terminal 16, resulting in a lockout.

Leak detection pressure switch should be set at 50% of the gas pressure upstream of the main shut-off valve.

### Example Leakage Rate Calculation

Using Siemens 1-1/2" VGD gas valves with an inlet gas pressure of .5 PSI, calculate the expected leakage rate which will cause the LDU11 to lockout setting one leak detection pressure switch at .25 PSI:

$$V_{\text{Leak}} = \frac{(P_i - P_{\text{set}}) \cdot V \cdot 3600}{P_{\text{atm}} \cdot t_{\text{Test}}}$$

$$P_i = .5 \text{ PSI}$$

$$P_{\text{set}} = .25 \text{ PSI}$$

$$P_{\text{atm}} = 14.7 \text{ PSI}$$

$$V = .026 \text{ ft}^3 \text{ (From table 1)}$$

$$T_{\text{test}} = 22.5 \text{ s (test 1)}$$

$$= 27.5 \text{ s (test 2)}$$

$$V_{\text{Leak}} = \frac{(.5 - .25) \cdot .026 \cdot 3600}{14.7 \cdot 22.5 \text{ (test1)}} = 0.07 \text{ ft}^3/\text{hr}$$

$$V_{\text{Leak}} = \frac{(.5 - .25) \cdot .026 \cdot 3600}{14.7 \cdot 27.5 \text{ (test2)}} = 0.06 \text{ ft}^3/\text{hr}$$

In this example, if the 1<sup>st</sup> gas valve is leaking at a rate of 0.07 ft<sup>3</sup>/hr or greater, the LDU will lockout during test 1. If the 2<sup>nd</sup> gas valve is leaking at a rate of 0.06 ft<sup>3</sup>/hr or greater, the LDU will lockout during test 2.

Note If the maximum permissible gas leakage rate ( $V_{\text{leak}}$ ) exceeds the desired leakage testing rate, use dual leak detection pressure switches.

## Wiring and setting of LDU... Dual Leak Detection Pressure Switches:

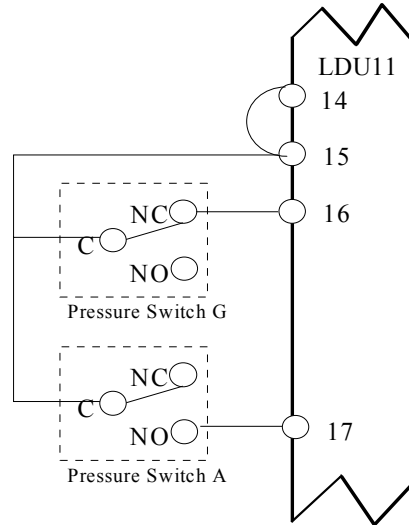

During Test 1, Terminal 15 is powered. After the area between the gas valves has been evaluated of pressure, pressure G switch should have power through terminal 15 to terminal 16. If the main gas valve is leaking, the area between the gas valves fills with gas, pressure switch A trips, sending power to terminal 17, causing a lockout.

Switch A needs to be set up to a maximum of 50% of the available gas pressure through the valves. The lower the pressure switch is set, the smaller of a leak will be detected through the blocking (downstream) gas valve. Setting the switch at or near atmospheric pressure may cause nuisance lockouts.

During Test 2, Terminal 15 is powered. With pressure between the gas valves, terminal 17 will also have power through pressure switch A. If the blocking gas valve is leaking, the area between the gas valves losses pressure, and pressure switch G trips, power is sent to terminal 16, causing a lockout.

Pressure Switch G need to be set at a minimum of 50%, up to 90%, of the inlet gas pressure through the valves. The higher this switch is set, the smaller a leak will be detected through the main (upstream) gas valve. Setting the pressure switch G at or near the inlet pressure may cause nuisance lockouts due to regulator fluctuations.

### Example

Using Siemens 1-1/2" VGD gas valves with an inlet gas pressure of .5 PSI, calculate the expected leakage rate which will cause the LDU11 to lockout with two LDU pressure switches, Pa set at .1 PSI, and Pg set at .4 PSI:

$$V_{\text{Leak}} = \frac{(\text{Pressure differential} * V * 3600)}{P_{\text{atm}} * t_{\text{Test}}}$$

$$P_i = .5 \text{ PSI}$$

$$P_a = .1 \text{ PSI}$$

$$P_g = .4 \text{ PSI}$$

$$P_{\text{atm}} = 14.7 \text{ PSI}$$

$$V = .026 \text{ ft}^3 \text{ (From table 1)}$$

$$T_{\text{test}} = 22.5 \text{ s (test 1)}$$

$$= 27.5 \text{ s (test 2)}$$

$$V_{\text{Leak}} = \frac{(.1) * .026 * 3600}{14.7 * 22.5 \text{ (test1)}} = 0.027 \text{ ft}^3/\text{hr}$$

$$V_{\text{Leak}} = \frac{(.5 - .4) * .026 * 3600}{14.7 * 27.5 \text{ (test2)}} = 0.022 \text{ ft}^3/\text{hr}$$

In this example, if the 1<sup>st</sup> gas valve is leaking at a rate of 0.027 ft<sup>3</sup>/hr or greater, the LDU will lockout during test 1. If the 2<sup>nd</sup> gas valve is leaking at a rate of 0.022 ft<sup>3</sup>/hr or greater, the LDU will lockout during test 2.

In the event of a lockout, the following steps need to be performed to determine the cause.

- 1) Check the leak detection switch to ensure it is an automatic reset switch.
  - 2) Determine at which point in the leak test sequence the lockout occurred, by viewing the front dial of the LDU control.
  - 3) If the lockout occurs during Test 1, manually leak test the upstream gas valve as recommended by NFPA 86. If the main valve is leaking, lockout the appliance and replace the valve.
  - 4) If the lockout occurs during Test 2, proceed to step 5.
  - 5) Determine the set-point of the leak test pressure switch. Check the inlet pressure in the gas train and the set point of the leak detection switch. Use the guidelines on the previous pages. Re-adjusting the leak detect pressure switch and reset the LDU.
  - 6) Check the wiring and functionality of the leak test pressure switch. If faulty, replace and/or rewire.
  - 7) Manually leak test the downstream valve as recommended by NFPA 86. If found to be leaking, lockout the appliance and replace the valve.
  - 8) Reset the LDU by pushing the clear window in front of the indicator dial (do not hold in).
  - 9) Contact local Siemens combustion representative for assistance.
-



**Connection examples for leak test before burner start-up:**

The LDU control may be wired in many different manners, depending upon application, burner control version and sequence of operations. Below is the generic wiring diagram for performing the test before burner start-up. Contact Siemens with questions or for assistance.

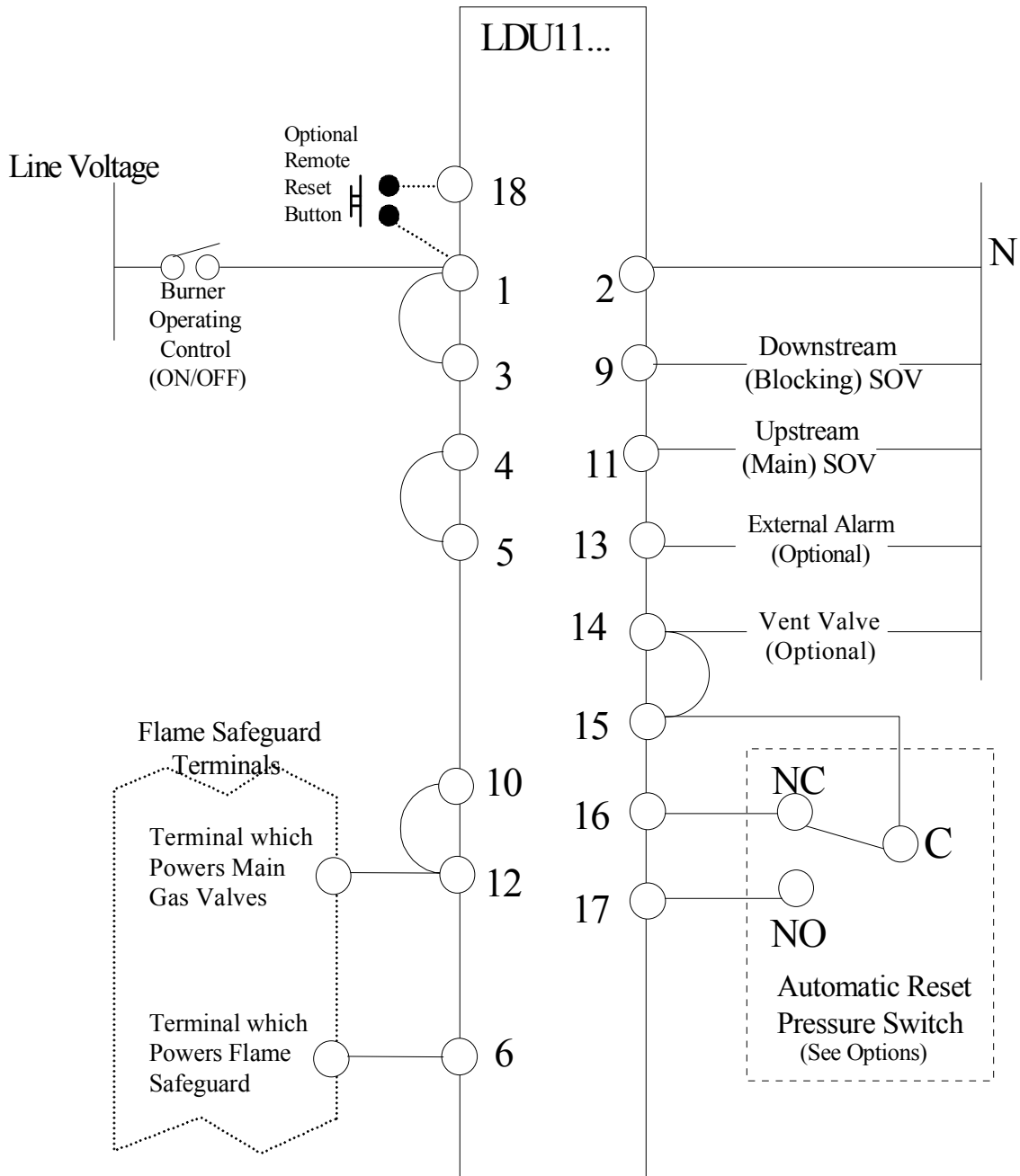

**Connection examples for leak test before burner start-up and after shut down with LFL burner control:**

Below is the wiring diagram using a LFL flame safeguard performing the leak test before burner start-up and after a controlled shut-down. This diagram only depicts the wires that are connected to the LDU control. Please consult Siemens manual 7451 for further wiring instructions for the LFL burner control.

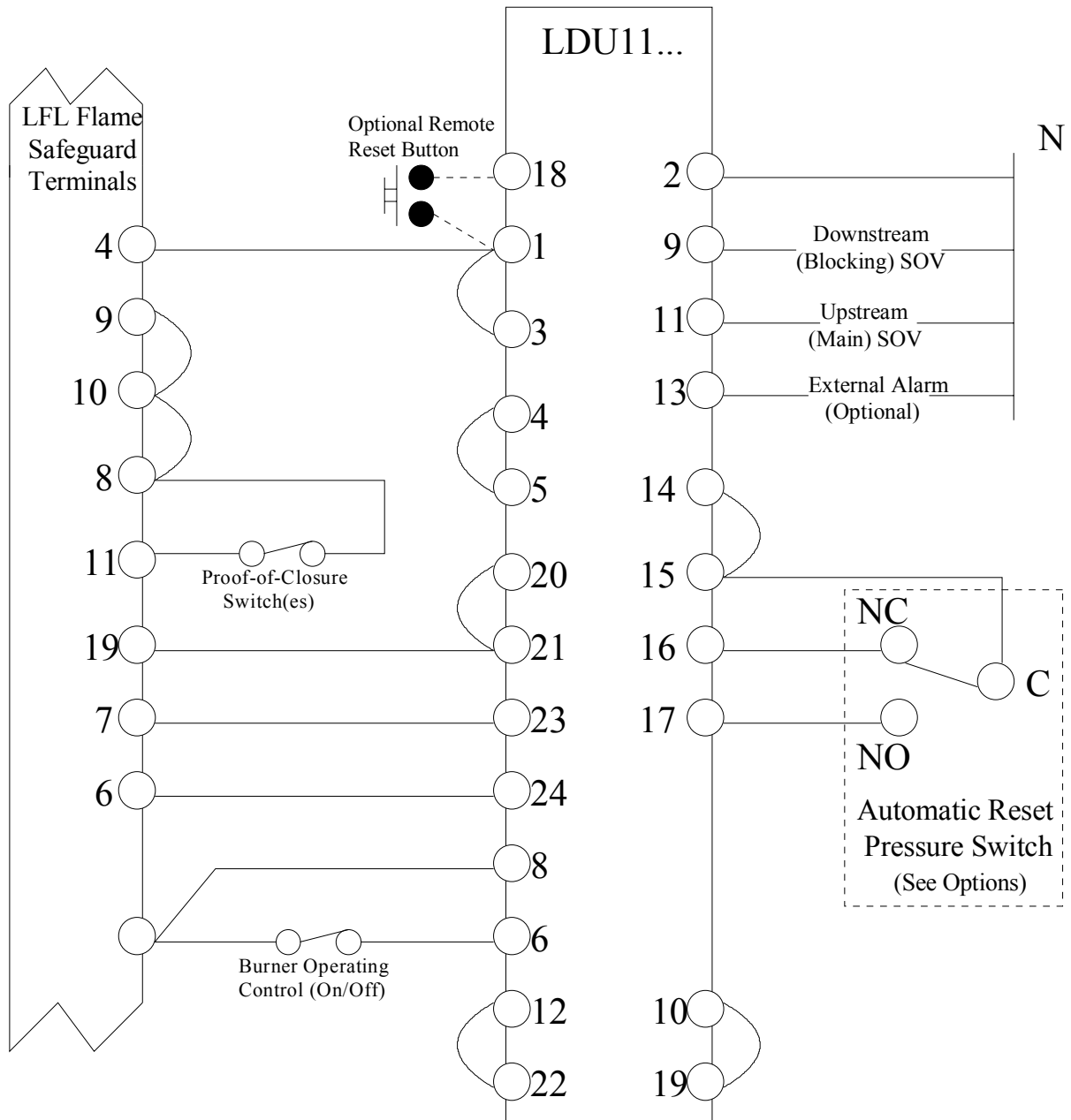

The base plates of the LDU and LFL controls are the same dimensions. Each is keyed during production in order that the controls may not be installed into the incorrect base plate.

Dimensions

Dimensions in inches

LDU11... with plug-in  
base AGM11

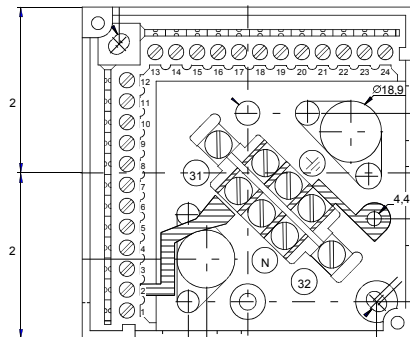
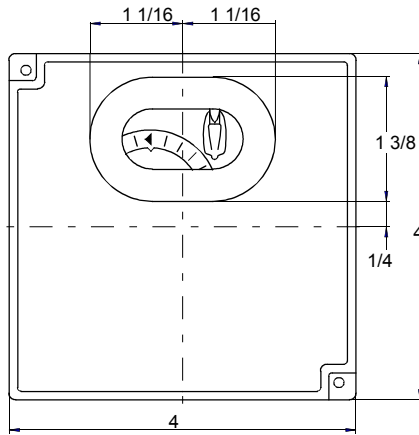
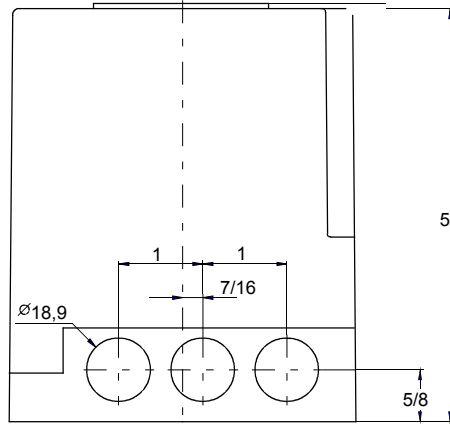

AGM11