

Installation & Maintenance Instructions

2-WAY INTERNAL PILOT-OPERATED SOLENOID VALVES
NORMALLY CLOSED AND NORMALLY OPEN OPERATION

SERIES

212

DESCRIPTION

The 212 series valves are 2-way, internal pilot operated valves available in normally closed and normally open constructions. They are available either AC or DC operated with composite plastic bodies. They come standard with leaded, DIN, or conduit hub connectors, and ASCO FasN™ end connectors. Dedicated constructions of the 212 series are suitable for water service.

OPERATION

IMPORTANT: Minimum operating pressure differential required is 5 psi.

Normally Closed: Valve is closed when the solenoid is de-energized; open when energized.

Normally Open: Valve is open when the solenoid is de-energized; closed when energized.

INSTALLATION

Check nameplate for correct catalog number, voltage, frequency, wattage, and service. Information is printed on the nameplate and coil. Never apply incompatible fluids, exceed pressure rating and temperature limitations of the valve.

Temperature Limitations

Refer to chart below for maximum valve ambient and fluid temperatures. Check catalog number and watt rating on nameplate.

Watt Rating (AC or DC)	Coil Class	Max. Ambient Temp (°F)	Max. Fluid Temp ‡ (°F)
6.3 (AC)	F	120	180
6.9 (DC)	F	120	180
10 (DC)	F	120	180

‡Lower for valves with solvent bond connector. See catalog for details.

⚠ CAUTION: Pressure and Temperature Hazard. Personal injury or equipment damage may occur. Do not exceed rating of the mating pipe. Do not allow liquid to freeze inside the valve or piping.

Positioning

These valves are designed to perform properly when mounted in any position. However, for optimum life and performance, the solenoid should be mounted vertically and upright to reduce the possibility of foreign matter accumulating in the core tube area.

Piping

Align valve so that the arrow on the valve bottom points in the desired direction for flow. Avoid pipe strain by properly supporting and aligning piping. When tightening the pipe, do not use the solenoid as a lever. Refer to Installation drawings for the different FasN end connectors. Solvent bond connector can be bonded to PVC pipe. The Turn & Lock Connector design is patent pending and can be used with copper or PEX tubing. NPT connectors can be used with standard NPT pipes. End connector kits are available separately and include one Locking Nut, Connector Piece, and O-ring. Refer to ASCO catalog pages for kit part numbers.

IMPORTANT: Flushing the valve for 15 minutes is recommended after installation, especially for consumable liquids.

IMPORTANT: For protection of the solenoid valve install a strainer or filter suitable for the service involved in the inlet side as close to the valve as possible. Periodic flushing is required depending on service conditions. See Series 8600 and 8601 for strainers.

Minimum Operating Pressure Differential

For all valves requiring a minimum operating pressure differential, the pressure and exhaust lines must be full size without restriction. Minimum operating pressure differential is printed on the nameplate and must be maintained for dependable operation

Wiring

Wiring must comply with local codes and the National Electrical Code. To facilitate wiring, the coil may be rotated 360°.

Solenoid Temperature

Standard catalog valves are supplied with coils designed for continuous duty service. When the solenoid is energized for a long period, the solenoid becomes hot and can be touched by hand only for an instant. This is a safe operating temperature. Any excess heating will be indicated by smoke and the odor of burning coil insulation

Mounting

The 212 valve series is compatible with Mounting Bracket kit 297395-004. Refer to I&M V9658 for mounting bracket instructions. The recommended screws for mounting to the bottom of the valve are #8 Plastite screws with 5/16" maximum engagement length.

IMPORTANT: Using screws that are too long or non-thread forming may damage the valve body.

MAINTENANCE

Preventive Maintenance

- Keep medium flowing through the valve as free from dirt and foreign material as possible.
- Periodic exercise of the valve should be considered if ambient or fluid conditions are such that corrosion, elastomer degradation, fluid contamination build up, or other conditions that could impede solenoid valve shifting are possible. The actual frequency of exercise necessary will depend on specific operating conditions. A successful operating history is the best indication of a proper interval between exercise cycles.

Causes of Improper Operation

Valve is not designed to be serviceable and should be replaced if the improper operation identified below is not corrected using the corresponding defined action:

- **Faulty Control Circuit:** Check the electrical system by energizing the solenoid. A metallic click signifies that the solenoid is operating. The absence of the click indicates loss of power supply. Check for loose or blown fuses, open-circuited or grounded coil, broken lead wires or splice connections.
- **Burned-Out Coil:** Check for open-circuited coil. Replace if necessary. Check supply voltage; it must be the same as specified on nameplate and as marked on the coil.
- **Low Voltage:** Check voltage across the coil leads. Voltage must be at least 85% of nameplate rating.
- **Incorrect Pressure:** Check valve pressure. Pressure to valve must be within range specified on nameplate.

⚠ WARNING: To prevent the possibility of death, serious injury or property damage, turn off electrical power, depressurize solenoid operator or valve, and vent fluid to a safe area before replacing.

APPROVALS



Coil

The coil has been tested and certified by UL and CSA Valve

- Tested and Certified by NSF International:
 - √ NSF-61 Annex G: Drinking water system components
 - √ NSF-169: Special purpose food equipment and devices
 - √ NSF-42: Drinking water treatments units – Material and Structural Integrity Requirements
 - √ NSF-372: Drinking water system components – Lead content certification
- The NSF Certification Program is accredited by the Standards Council of Canada and ANSI.

FasN NPT Connector Installation

(Refer to Figures 1, 2 and 3)

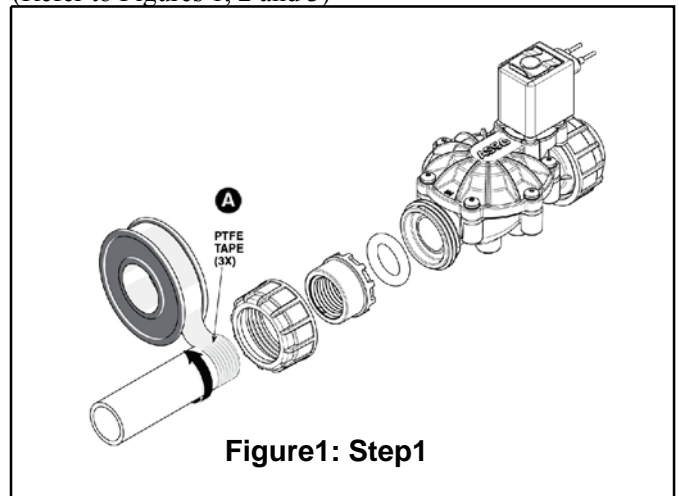

Figure 1: Step 1

1. Apply 3 loops of PTFE tape to NPT pipe.

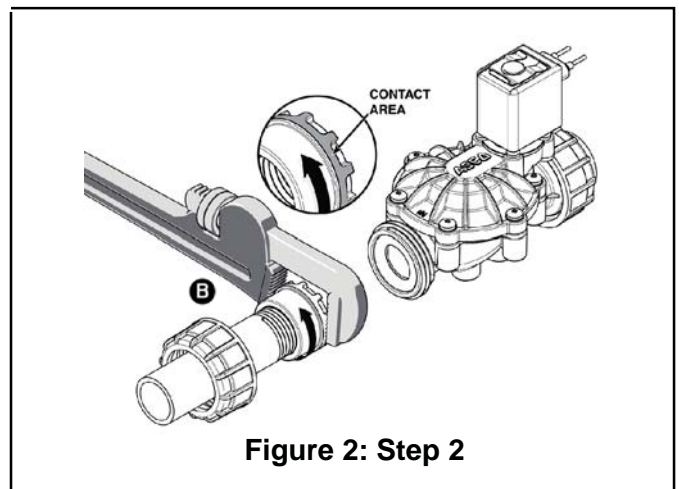

Figure 2: Step 2

2. Tighten connector approximately 4 turns from initial engagement or until leak-tight. NOTE: Excessive tightening may damage fittings. Only grip connector in the area shown above.

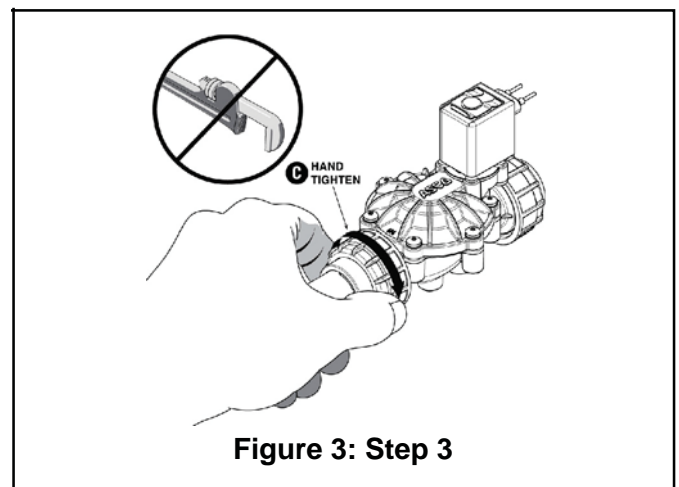
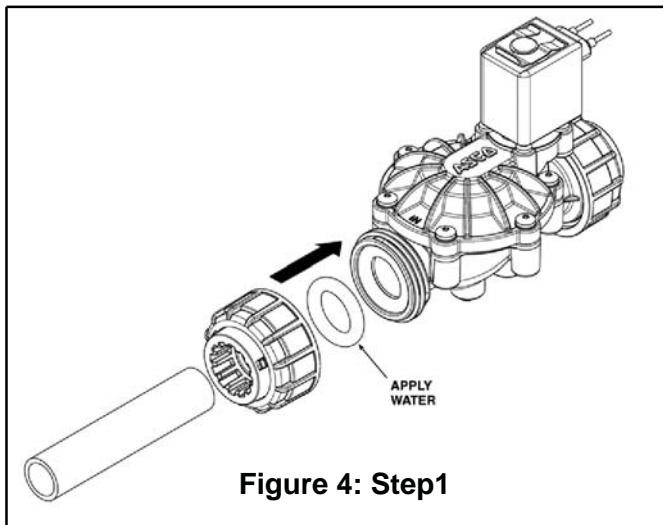

Figure 3: Step 3

3. Hand tighten locking nut. (Approx. 1 ft-lb of torque)

FasN Turn & Lock Connector Installation

(Refer to Figures 4, 5 and 6)



1. Wet o-ring with water before inserting into body.

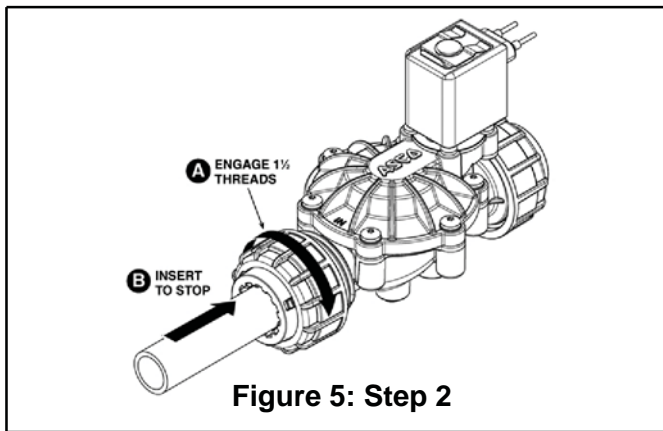

2. Engage locking nut 1 1/2 threads with body. Then insert pipe to stop in body.

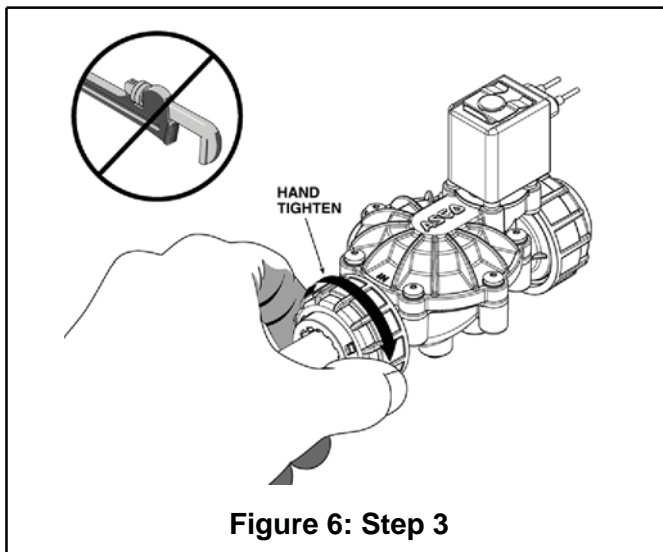

3. Hand tighten locking nut to secure tubing. (Approx. 1 ft-lb of torque)

FasN Solvent Bond Connector Installation

(Refer to Figures 7, 8 and 9)

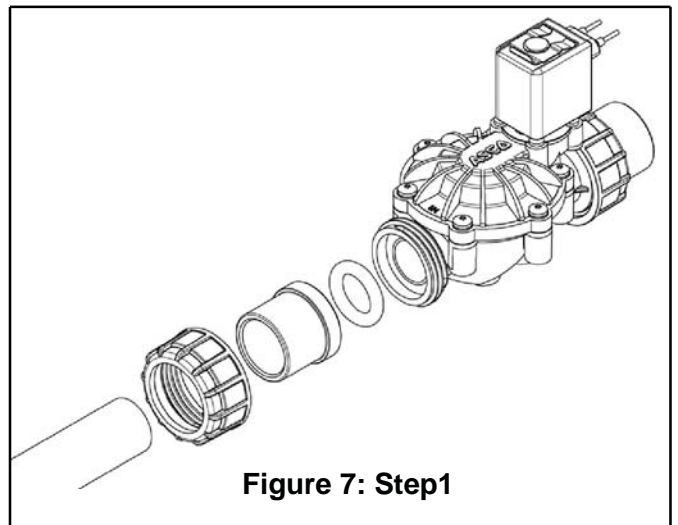

1. Apply primer and PVC pipe cement to pipe and connector according to cement manufacturer's instructions.

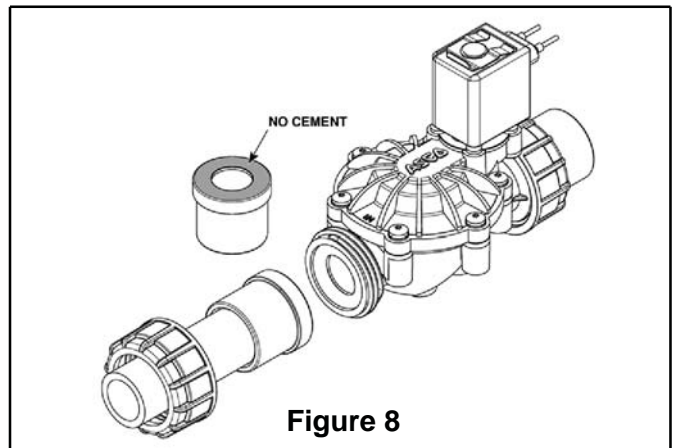

⚠ CAUTION: Do not allow any cement on the connector surface shown above.

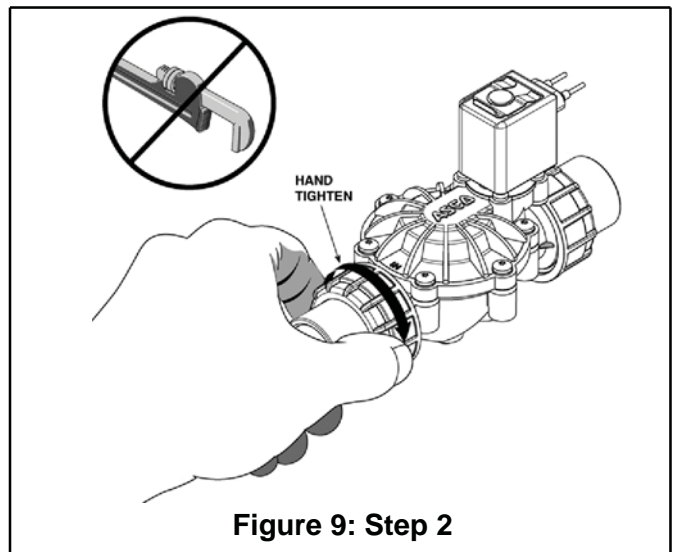

2. Hand tighten locking nut. (Approx. 1 ft-lb of torque)