

**Pneumatic Valve Actuators
General Instructions**

APPLICATION

MK-8800 series actuators used to control 2-1/2" through 4" VB-9000 series valves. MK-8900 series actuators used to control 5" and 6" VB-9000 series valves.

SPECIFICATIONS

Effective Area: 100 sq. in. (645 cm²).

Construction:

Housing, Die cast aluminum.

Diaphragms, Replaceable beaded molded neoprene.

Stroke: See table.

Spring: Retracts actuator shaft and raises valve stem on loss of air pressure.

Nominal Spring Range: See table.

Starting Point: Adjustable ± 1 psi (7 kPa).

Maximum Air Pressure: 30 psig (207 kPa).

Ambient Temperature Limits:

Shipping, -40 to 220°F (-40 to 104°C).

Operating, -20 to 220°F (-29 to 104°C).

Air Connection: 1/8" FNPT.

Valve Linkage: Order separately AV-496.

Valve Stroke Position Indication: 1/8" (3 mm) increments.

Mounting: In any upright position with actuator head above 45° of the center line of the valve body. Actuator head may be swiveled to any convenient position.

Dimensions: See Table-1.

OPTIONS

None

ACCESSORIES

AK-52309-500 Positive positioner with linkage
Tool-95 Pneumatic calibration tool kit

Table-1 Specifications.

Part Number	Nominal Spring Range ^a		Nominal Stroke		Dimensions		For Use With Valve Bodies
	psig	kPa	in.	mm	in.	mm	
MK-8801	3-8	21-55	1	25.4	11-3/4 high x 10-1/2 wide x 10-1/2 deep	298 high x 267 wide x 267 deep	2-1/2 – 4" VB-9213 VB-9223 VB-9313
MK-8811	5-10	34-69	1	25.4			
MK-8821	8-13	55-90	1	25.4			
MK-8901	3-8	21-55	2	50.8	12-3/4 high x 10-1/2 wide x 10-1/2 deep	324 high x 267 wide x 267 deep	5 & 6" VB-9213 VB-9223 VB-9313
MK-8911	5-10	34-69	2	50.8			
MK-8921	8-13	55-90	2	50.8			

^a Nominal (no load) spring ranges are based on maximum 1" (25.4 mm) or 2" (50.8 mm) stroke.

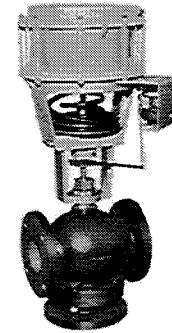

Figure-1 MK-8800 Series Actuator with Valve Assembly.

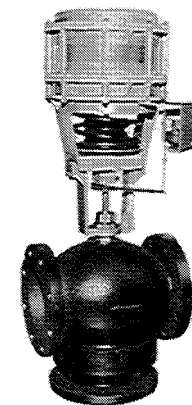

Figure-2 MK-8900 Series Actuator with Valve Assembly.

INSTALLATION

The actuator is normally shipped assembled to a valve body. These instructions are intended for use where the actuator is to be installed as a replacement unit, or when the actuator must be removed during valve installation.

The actuator is generally installed in an upright position and may be swiveled to any convenient position for connection to the control air line.

Caution: Do not install the actuator below 45° of the center line of the valve.

Removing Actuator from Mounting Bracket

1. Remove (2) connecting clamp halves between actuator piston sleeve and valve stem sleeve. A slight amount of air pressure supplied to the actuator may be necessary to eliminate spring load forces.
2. Remove (2) bolts holding actuator to mounting bracket and lift actuator up. MK-8900 series will have (2) spacers between mounting bracket and actuator.

Note: It is not necessary to remove mounting bracket from valve body in order to service the actuator.

Removal of Mounting Bracket from Valve Body

If it is necessary to remove the mounting bracket from the valve body, remove stem sleeve, indicator plate, locking nut and packet nut. Then remove bracket nut. (See Figure 3).

Installing Actuator on Valve Body

If mounting bracket has been removed, re-install it making certain that the bracket nut is securely tightened, and the packing nut is tightened (4) turns.

1. Place the actuator on the mounting bracket and secure with (2) bolts. Be sure air connection is in a proper location for the application.
2. Secure the actuator piston sleeve to valve stem sleeve with (2) connecting clamp halves. Secure with (2) bolts. It may be necessary to apply a slight amount of air pressure to the actuator to butt the sleeves together.

START POINT ADJUSTMENT

The proper start point is set at the factory. The air pressure, when applied to the actuator, causes the piston to just begin to move downward under a no load condition.

To raise start point, rotate adjustment nut clockwise (CW). To lower start point, rotate adjustment nut counterclockwise (CCW).

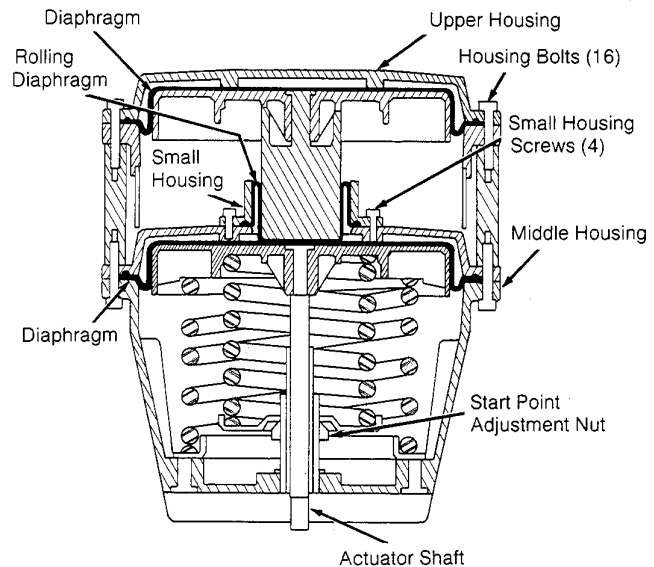

Figure-3 AV-496 Valve Linkage for MK-88XX and MK-89XX.

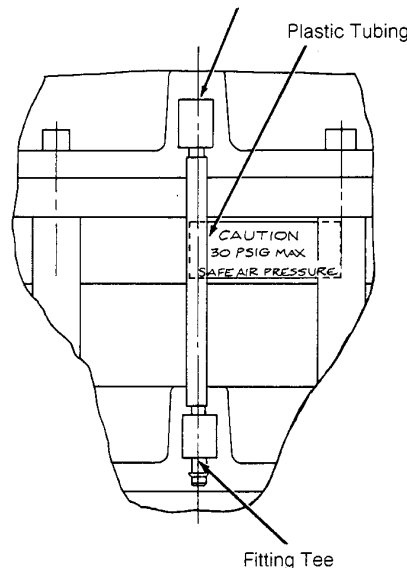

Figure-4 MK-8XXX Actuator Cutaway (MX-88XX Shown).

FIELD SERVICE

Replacing Actuator Diaphragms (See Figures 3 and 4)

1. Remove actuator from mounting bracket.
 - a. Remove (2) connecting clamp halves between actuator piston sleeve and valve stem sleeve. A slight amount of air pressure supplied to the actuator may be necessary to eliminate spring load forces.
 - b. Remove (2) bolts holding actuator to mounting bracket and lift actuator up.

Note: It is not necessary to remove mounting bracket from valve body in order to service the actuator.

Removal of Mounting Bracket from Valve Body

If it is necessary to remove the mounting bracket from the valve body, remove stem sleeve, indicator plate, locking nut and packing nut. Then remove bracket nut. (See Figure 3).

2. Remove actuator piston sleeve. Slide (2) large washers (1-1/4" O.D. x 9/16" I.D. X 1/8" thick) over the actuator shaft and screw a 1/2"-20 thread hex nut against the washers.
3. Tighten the nut (5 turns) until the actuator shaft has been pulled (compressing the actuator springs) approximately 1/4".

Caution: Do not remove this retaining nut until reassembly is completed. Strong spring forces are present.

4. Remove upper and middle housing, bolts and diaphragms as required. (See Figure 4).
5. Install replacement diaphragms in reverse order. Be sure diaphragm ribs fit properly in the actuator cover grooves.
6. Reassemble housing and remove retaining nut and washer on the actuator shaft.

Caution: Make certain that housing bolts are securely tightened prior to removal of retaining nut on actuator shaft.

7. Reassemble the actuator to the mounting bracket using mounting bolts supplied. Spacers (2) are required on MK-8900 series actuators.

Actuator Springs: Not field replaceable. Return actuator to factory for service.

MAINTENANCE

This is a quality product. Regular maintenance of the total system is recommended to assure sustained optimum performance.

Copyright 2008, TAC
All brand names, trademarks and registered
trademarks are the property of their respective
owners. Information contained within this
document is subject to change without notice.

TAC
1354 Clifford Avenue
P.O. Box 2940
Loves Park, IL 61132-2940
www.tac.com

F-21662-2

t.a.c. [®]
by Schneider Electric