



R820 SERIES SCR POWER CONTROLS

- 240 Vac up to 600 Vac models
- 10 Amps up to 75 Amps models
- 1 phase or 3 phase models



DESCRIPTION

The Viconics R820 series SCR power controls are designed for cost effective, precise modulation of electric loads for most electric heating applications.
(Applicable on resistive loads only)

The R820 series consists of SCR's power controls, c/w factory assembled heatsink for surface or in-panel mounting.

FEATURES

- Microcomputer based.
- Dip switch configurable
- Integrated over temperature thermostatic protection (self resetting) Auto shut off when SCR ambient temperature is above 82°C (180°F)
- Complete with factory installed heatsink
- For surface or in-panel mounting
- CSA approved for Canada and USA
- UL recognized
- Pulse status led for servicing & trouble shooting
- 2 years warranty

They are compatible with many industry standard signals. A typical application would be to control a modulating electric duct heater with a 0 to 10 Vdc control signal from an analog room thermostat. The R820 power controller also contain four dip switch to adjust to the following control signals:

- 0 to 10 Vdc control signal (2 to 10 Vdc control range)
- 4 to 20 mA control signal
- 0 to 135 Ω control signal

SCR INSTALLATION

Important.

All external safety devices like: contactors, relays, flow switch & thermal protections are to be supplied and installed by other.

When the SCR is installed inside a panel, the enclosure needs to be adequately louvered for proper ventilation and heat dissipation. Call the factory for the derating amperage curves for these specific applications.

Electronic controls require special care for wiring and startup. To avoid problems, carefully follow the procedures below.

Look at the wiring diagrams, and study them carefully. Be sure that you understand how the system is supposed to work.

A) Location:

- 1- Can be installed inside a louvered approved cabinet or with the heatsink mounted externally.
- 2- Must be installed away from excessive heat source.
- 3- Nothing must restrain air circulation to the heatsink.

B) Installation:

- 1- If installed completely inside a cabinet, use the mounting tabs on the heatsink to secure the SCR to the back plate of the panel.
- 2- If installed with heatsink outside the cabinet, use the proper model mounting template for the cut out dimensions and to check for mounting obstructions.
- 3- Respect mounting orientation (this side up).
- 4- Mount the heatsink vertically on the side of the cabinet for proper heat dissipation.
- 5- Do not relocate the power switching modules on the heatsink.

HOW TO ORDER

Models Available	Maximum Voltage	Maximum Amperage	Phase
R820-211	Up to 240 V.	10 A.	1 Phase
R820-213	Up to 240 V.	10 A.	3 Phase
R820-321	Up to 347 V.	25 A.	1 Phase
R820-323	Up to 347 V.	25 A.	3 Phase
R820-341	Up to 347 V.	45 A.	1 Phase
R820-343	Up to 347 V.	45 A.	3 Phase
R820-421	Up to 480 V.	25 A.	1 Phase
R820-423	Up to 480 V.	25 A.	3 Phase
R820-441	Up to 480 V.	45 A.	1 Phase
R820-443	Up to 480 V.	45 A.	3 Phase
R820-471	Up to 480 V.	75 A.	1 Phase
R820-621	Up to 600 V.	25 A.	1 Phase
R820-623	Up to 600 V.	25 A.	3 Phase
R820-641	Up to 600 V.	45 A.	1 Phase
R820-643	Up to 600 V.	45 A.	3 Phase
R820-671	Up to 600 V.	75 A.	1 Phase

** Only 2 legs of the circuit are controlled on 3 phase systems.

SPECIFICATIONS

Operating Conditions: 0°C to 80°C (32°F to 176°F)
0 % to 95 % R.H. non-condensing
See power derating curves document

Thermostatic protection: Self resetting. Auto shut off when SCR ambient temp. is above 82°C (180°F)

Power supply: 24 Vac -15%, +10% 50/60 Hz; 2 VA

Use a Class 1 (properly fused) or Class 2, CSA or UL recognized transformer.

HIGH VOLTAGE WIRING

General cautions:

- High voltages are present on the terminals of these devices. Please read all the instruction in this manual carefully.
- The 45 & 75 Amps models need to be wired with the supplied high voltage lugs. **Attach the wire to the lug first**, then screw the lug to the power module.
- Have the wiring done by a qualified a skilled professional.
- High voltage and amperage can be fatal.
- All wiring must conform with national electrical code regulations.
- The instrument must be wired before applying power.
- Protect circuits with semi conductor fuses.
- For in panel installation, derating amperage curves are available from the factory.

Note:

These instruments have undergone rigorous tests and verifications prior to shipment to ensure proper and reliable operation in the field. However, like other such products, they are subject to failure. It is therefore the responsibility of the installer / user / electrical panel designer to incorporate safety features and devices (such as relays, flow switch, thermal protections, etc.....) to protect the entire system from catastrophic failure.

R820 DIMENSIONS & INSTALLATION

- Mounting instructions & templates are available from the factory.
- The cutout templates include holes position for heatsink attachment to the electrical cabinet
 - ❖ R810 & single phase R820 will have 2 mounting screw, 1 on each side.
 - ❖ Three phase R820 will have 4 mounting screw, 2 on each side.
- Respect mounting orientation (this side up).
- Mount the heatsink vertically on the side of the cabinet for proper heat dissipation.
- If mounted on top or bottom of the cabinet, derate maximum usable amperage by 25%.
- Do not relocate the power switching modules on the heatsink.

"A" Template

Typical template:

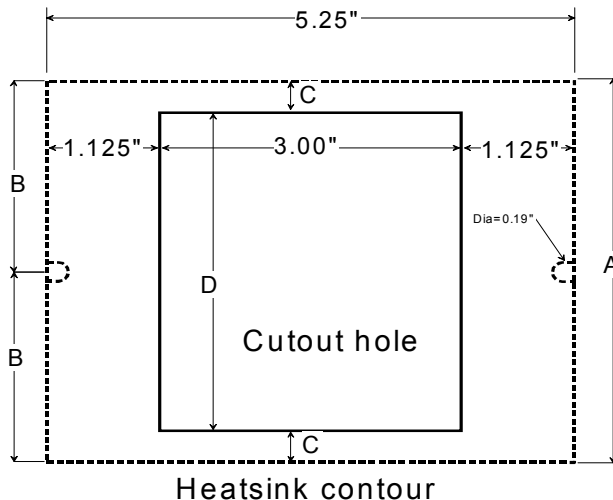

Typical installation:

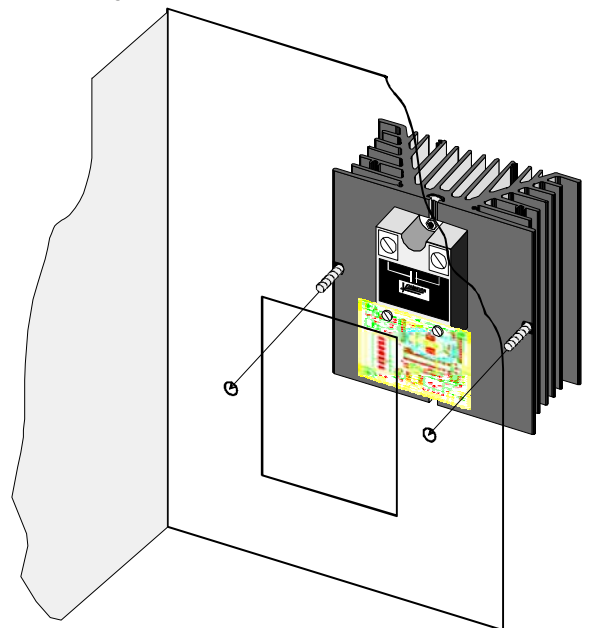

R820 single phase	A	B	C	D	Weight (LBS)
R820-211	4.5 "	2.25"	0.375"	3.75"	1.80
R820-321	4.5 "	2.25"	0.375"	3.75"	1.80
R820-341	6.5 "	3.25"	1.375"	3.75"	2.40
R820-421	4.5 "	2.25"	0.375"	3.75"	1.80
R820-441	6.5 "	3.25"	1.375"	3.75"	2.40
R820-471	10.0 "	5.00"	3.125"	3.75"	3.50
R820-621	4.5 "	2.25"	0.375"	3.75"	1.80
R820-641	6.5 "	3.25"	1.375"	3.75"	2.40
R820-671	10.0 "	5.00"	3.125"	3.75"	3.50

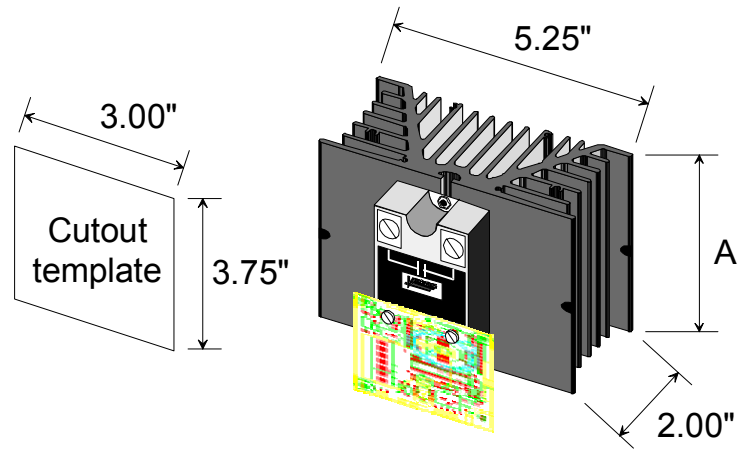

R820 three phase	A	B	C	D	Weight (LBS)
R820-213	6.5 "	3.25"	0.375"	5.75"	2.60
R820-323	10.0 "	5.00"	2.125"	5.75"	3.70
R820-343	10.0 "	5.00"	2.125"	5.75"	3.70
R820-423	6.5 "	3.25"	0.375"	5.75"	2.65
R820-443	10.0 "	5.00"	2.125"	5.75"	3.70
R820-623	6.5 "	3.25"	0.375"	5.75"	2.65
R820-643	10.0 "	5.00"	2.125"	5.75"	3.70

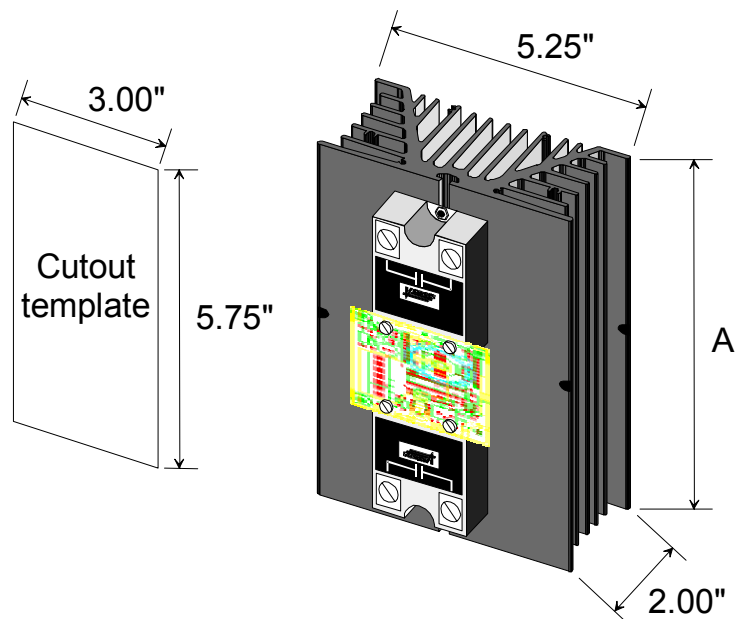

DIP SWITCH ADJUSTMENTS PER APPLICATIONS

INPUT SIGNAL	SWITCH #1	SWITCH #2	SWITCH #3	SWITCH #4
0 to 10 Vdc control signal (2 to 10 Vdc control range)	Off	Off	Off	On
4 to 20 mA control signal	Off	Off	On	Off
0 to 135 Ω control signal	On	On	Off	Off

TYPICAL APPLICATIONS

0 To 10 Vdc Room Or Duct Thermostat Control

Dip switch position	S1	S2	S3	S4
0 to 10 Vdc control signal	Off	Off	Off	On

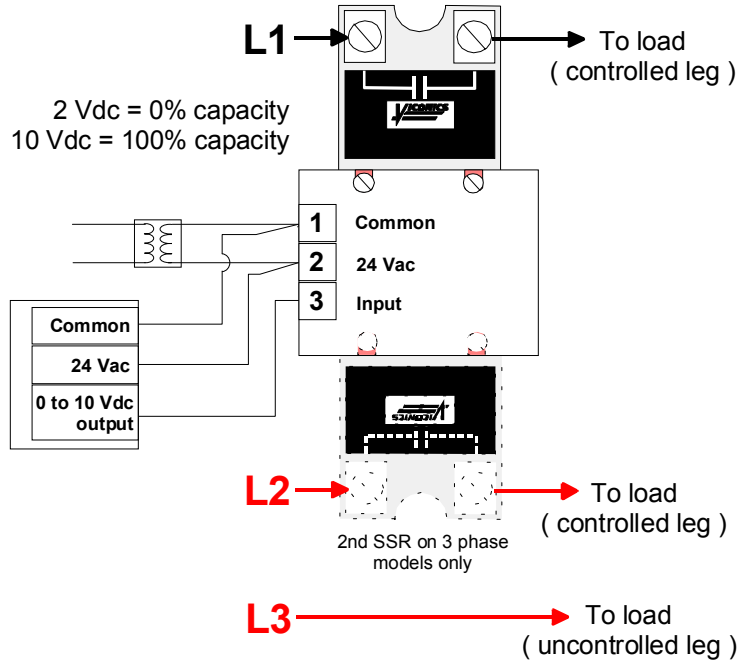
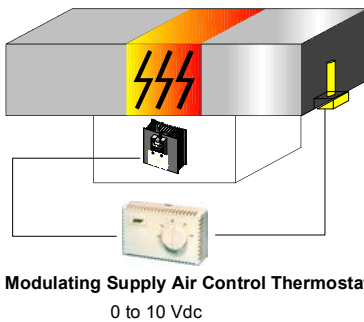
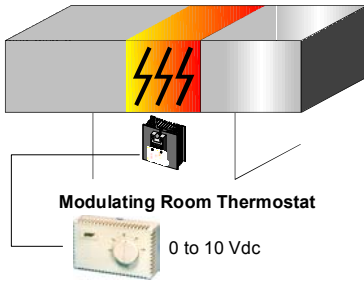

0 To 10 Vdc From a Building Automation System

Dip switch position	S1	S2	S3	S4
0 to 10 Vdc control signal	Off	Off	Off	On

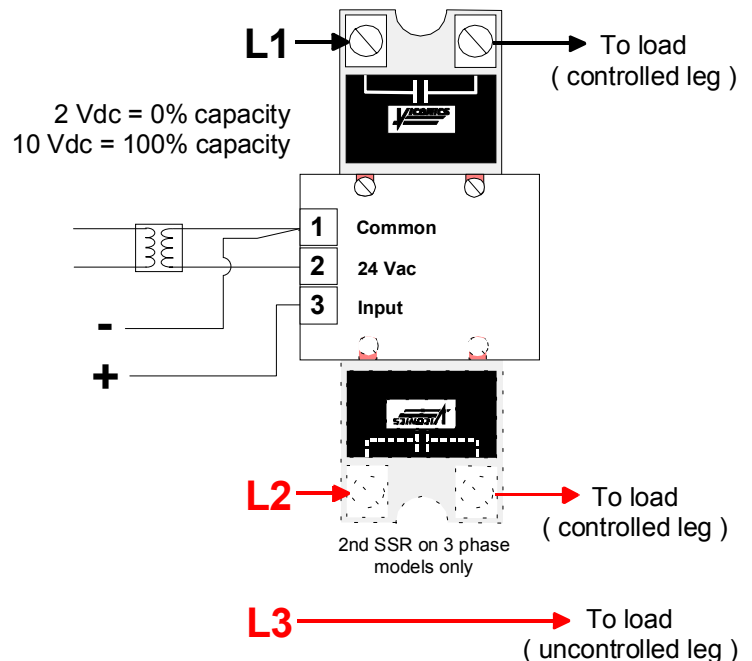
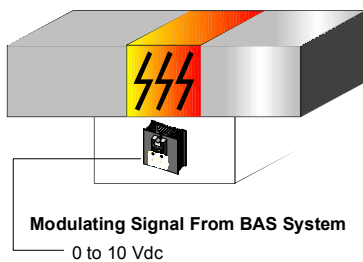

0 To 135 Ω Room Or Duct Thermostat Control

Dip switch position	S1	S2	S3	S4
0 to 135 Ω control signal	On	On	Off	Off

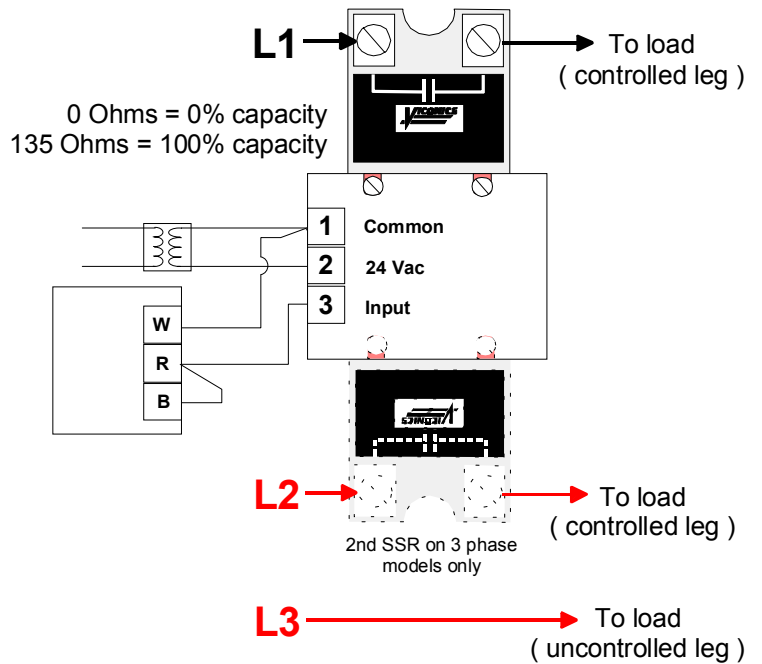
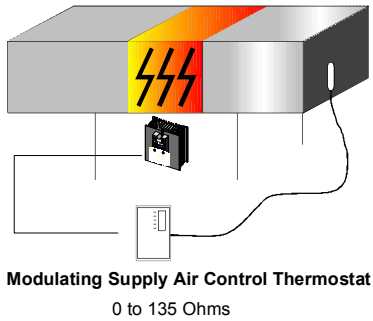
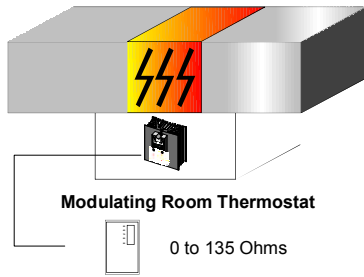

4 To 20 mA From a Building Automation System

Dip switch position	S1	S2	S3	S4
4 to 20 mA control signal	Off	Off	On	Off

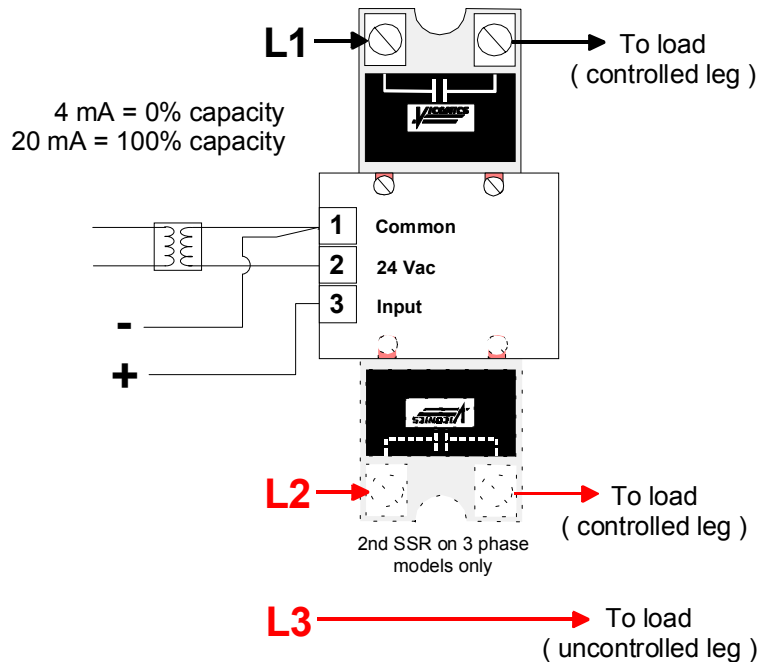
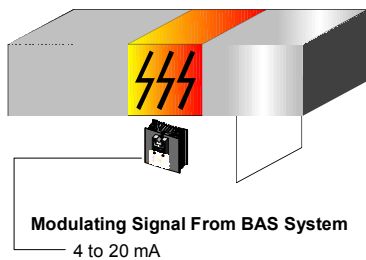

24 VAC POWER & WIRING

- It is not necessary to ground any leg of the transformer to earth with the controller card.
- The controller uses internally a half wave rectifier bridge. On 0 to 10 Vdc control signal, the reference of the control signal is the Common of the power supply of the SCR controller card.
- Use a Class 1 (properly fused) or Class 2, CSA or UL recognized transformer.