

SAX Electronic Valve Actuator



Product Description

The SAX Electronic Valve Actuator requires a 24 Vdc or 24 Vac, Class 2, supply signal to control a Flowrite™ 599 Series valve with a 3/4-inch (20 mm) standard stroke.

Product Numbers

SAX61.03U Proportional Control Actuator
 SAX81.03U Three-position Control Actuator

Warning/Caution Notations

WARNING:		Personal injury/loss of life may occur if you do not follow a procedure as specified.
CAUTION:		Equipment damage or loss of data may occur if you do not follow a procedure as specified.

Required Tools

- 4 mm hex wrench, or 10 mm wrench
- Flat-blade screwdriver or Phillips screwdriver to remove wiring compartment cover

Expected Installation Time

30 minutes Wiring a factory-installed actuator

45 minutes Field replacement of actuator

Prerequisites



WARNING:

If mounting the actuator to a valve already in line, either close the shut-off valves in the piping (upstream first, then downstream) or switch off the pump to allow the differential pressure in the valve to drop.

Mounting Positions

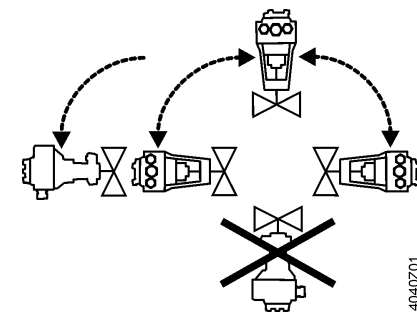

Figure 1. Acceptable Indoor Mounting Positions.

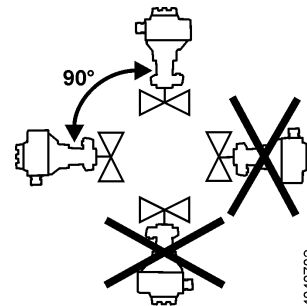
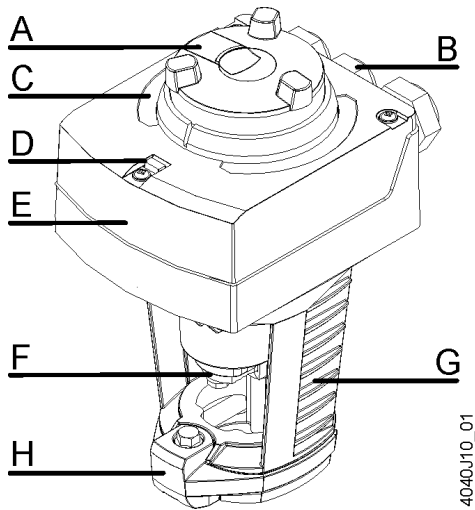

Figure 2. Acceptable Outdoor Mounting Positions with Weather Shield.



A	Manual adjuster (with slide switch)
B	Wiring knockouts
C	Position indication
D	Status indication
E	Housing cover
F	Valve stem coupling
G	Yoke
H	Bonnet connection U-bracket

Installation



CAUTION:
 Do not damage or scratch the polished surface of the valve stem.

Mounting an Actuator to a Valve

1. Ensure stem connection plate in the Valve Stem Coupling is in the OPEN position. See Figure 3.

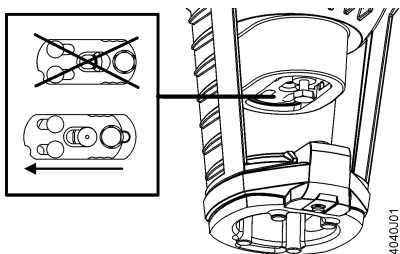

Figure 3.

2. Open the bonnet connection U-bracket. See Figure 4.

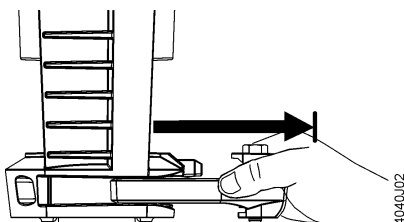

Figure 4.

3. Pull the valve stem to the fully extended position. Then, slide the actuator on the valve bonnet. See Figure 5.

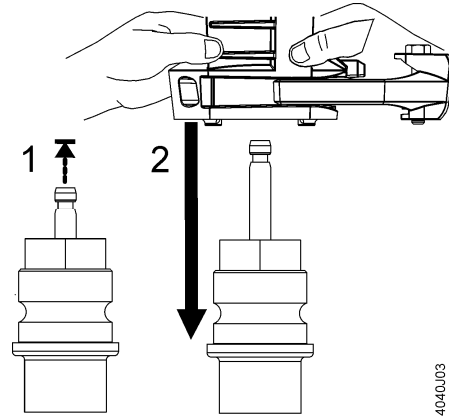

Figure 5.

4. Completely close the bonnet connection U-bracket. See Figure 6.

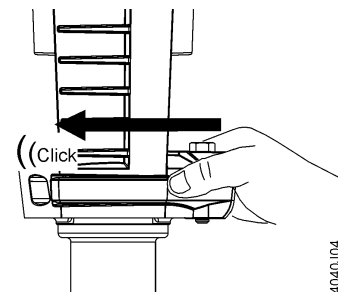

Figure 6.

NOTE: Position the actuator to accommodate the wiring. Hold the actuator in place while tightening the actuator U-bracket bolt.

5. Tighten the U-bracket bolt using a 10 mm wrench (or 4 mm Allen wrench) to 5 Nm (44 in-lbs) torque. See Figure 7.

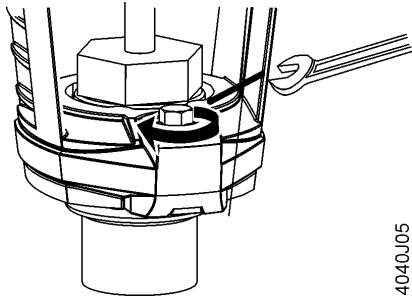

Figure 7.

6. Rotate the manual adjuster clockwise to manually extend the actuator shaft until it covers the head of the valve stem. See Figure 8.

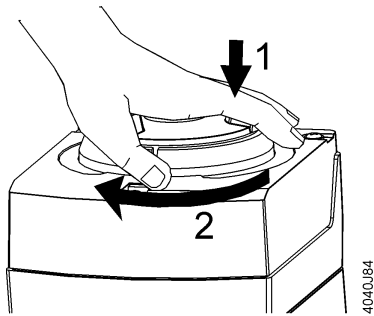

Figure 8.

7. Close the stem connection plate securely over the valve stem. See Figure 9.

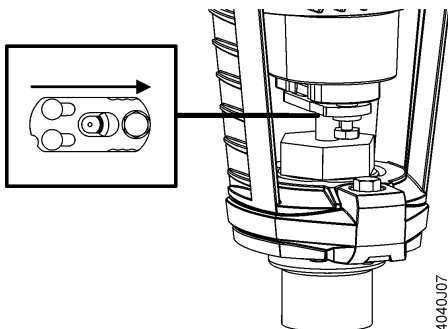

Figure 9.

8. Secure the stem connection plate by tightening the bolt, using a 10 mm wrench (or 4 mm Allen wrench). See Figure 10.

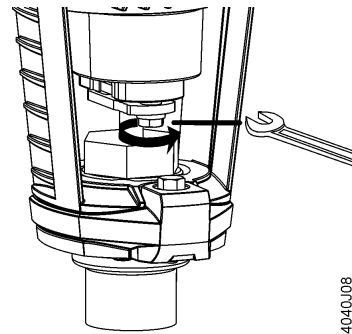

Figure 10.

The mounting is now complete.

Removing the actuator from a valve

1. Loosen the stem connection plate in the Valve Stem Coupling by loosening the bolt, using a 10 mm wrench (or 4 mm Allen wrench).
2. Open the stem connection plate over the valve stem.
3. Manually retract the actuator shaft by turning the Manual Adjuster counterclockwise until it reveals the head of the valve stem.
4. Loosen the U-bracket using a 10 mm wrench (or 4 mm Allen wrench).
5. Completely open the bonnet connection U-bracket.
6. Push the valve stem to the fully retracted position. Then, slide the actuator off the valve bonnet.
7. Remove the actuator from the valve, being careful not to damage the valve stem.
8. Close the bonnet connection U-bracket.

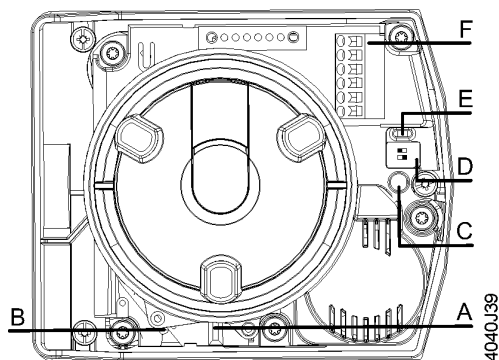

Figure 11. SAX Actuator with Cover Removed.

- A Plug-in space for...
 - Potentiometer ASZ7.5.. (SAX81.03U only) or
 - Auxiliary switch ASC10.51.

- B Plug-in space for...
 - Function module AZX61.1 (SAX61.03U only), or
 - Auxiliary switch ASC10.51

- C LED (SAX61.03U only)

- D DIP Switches (SAX61.03U only)

- E Calibration Slot (SAX61.03U only)

- F Connection Terminals

Wiring

Do not use autotransformers. Use earth ground isolating step-down Class 2 power supply transformers.

Determine supply transformer rating by summing total VA of all actuators used. The maximum rating for a Class 2 step-down transformer is 100 VA.

It is recommended that no more than 10 actuators are powered by one transformer.

Parallel Control of Actuators

SAX81.0-3U -Three-position actuators must have their own specific controller.

SAX61.03U - Up to 10 actuators can be driven in parallel from a single controller output with a rating of 1 mA. Modulating actuators have an input impedance of 100KΩ.

NOTE: Use either a Phillips head screwdriver or a flat-blade screwdriver to remove the wiring compartment housing cover for access to the terminal block and DIP switches.

DIP Switch Setting (SAX61.03U only)

Switch 1: Control Signal

Select between 0 to 10 Vdc or 4 to 20 mA input signal for terminal Y (0 to 10 Vdc default).

Switch 2: Flow Characteristic

Do not change the flow characteristic switch. The proper flow characteristic is designed into the Flowrite 599 Series valve.

NOTE: Changing the default setting will modify an equal percentage valve to a linear flow characteristic. When set to default, the flow characteristic is determined by the valve body.

Table 1. DIP Switch Settings.

	Positioning Signal "Y"		Position Feedback "U"	Flow Characteristic	
OFF 1)		0 to 10 Vdc	0 to 10 Vdc		Default
ON		DC 4 to 20 mA	0 to 10 Vdc		Modified

1) Factory setting: All DIP switches are set to OFF.

Wiring, SAX61.03U

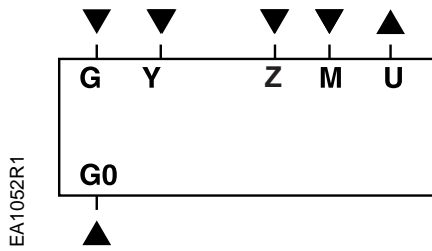

Figure 12. Connecting Terminals (SAX61.03U).

G0	System Neutral (SN)
G	System Potential (SP)
Y	Positioning signal for 0 to 10 Vdc/4 to 20 mA
M	Measuring neutral
U	Position feedback 0 to 10 Vdc
Z	Positioning signal forced control

Wiring, SAX81.03U

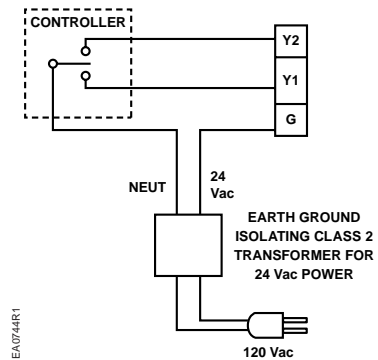

Figure 14. Connecting Terminals (SAX81.03U).

G	System potential (SP)
Y1	Positioning signal (actuator's stem extends)
Y2	Positioning signal (actuator's stem retracts)

Wiring Diagrams (SAX61.03U)

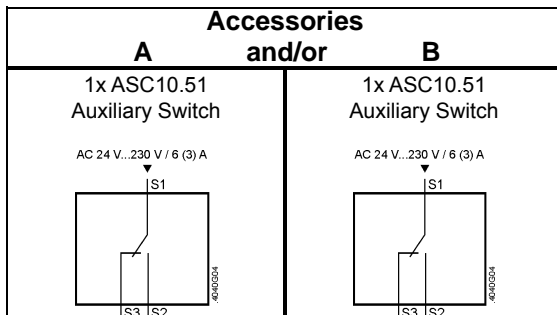
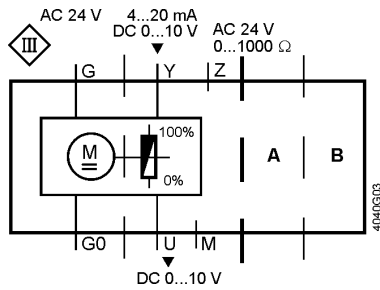

Figure 13. Applications.

The wiring diagrams show all possible connections. The application determines which connections are used. A and B are optional auxiliary switches.

Wiring Diagrams (SAX81.03U)

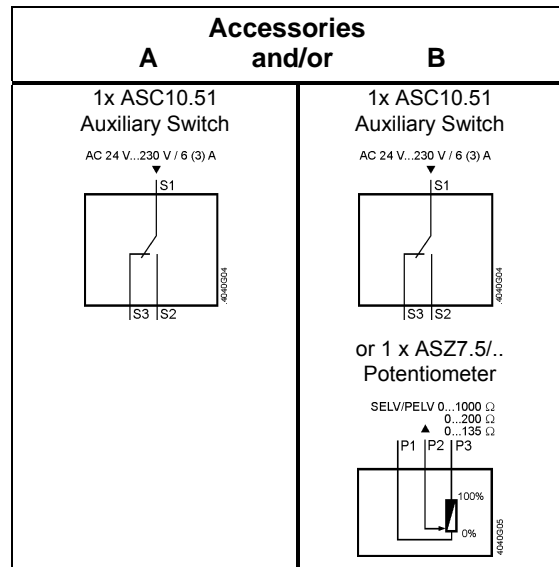
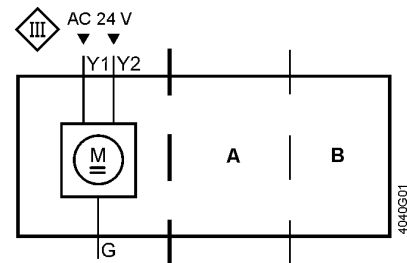

Figure 15. Application.

The wiring diagrams show all possible connections. The application determines which connections are used.

Manual Override

Manual operation

When pushing the manual adjuster down (1), it engages and the actuator can be manually operated.

When turning the manual adjuster in a clockwise/counterclockwise direction (2), the actuator's stem extends/retracts. See Figure 16.

An overload protection prevents damage to the manual adjuster.

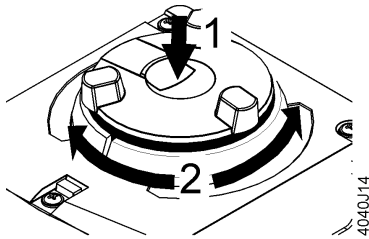

Figure 16.

Setting the position

Upon actuation and locking the slide switch (see Figure 17), the manual adjuster remains engaged.

When in this mode, do not turn the manual adjuster.

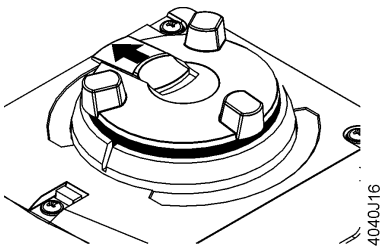

Figure 17.

Disengaging the setting

When resetting the slide switch (see Figure 18), the manual adjuster returns to Automatic Mode.

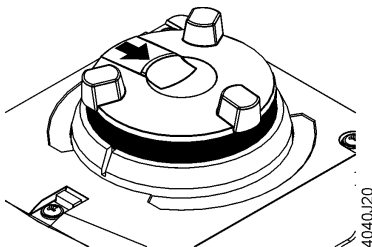

Figure 18.

Commissioning and Operation

Function Check and Calibration

Mechanical Check

Prior to making the function check, ensure that:

- Actuator is mechanically connected to a Siemens valve.
- Actuator is in Manual Operation mode.

The actuator can be operated with the help of the Manual Adjuster.

Manual Adjuster Action	Actuator Response
Turning in clockwise direction	Actuator's stem extends
Turning in counter-clockwise direction	Actuator's stem retracts

NOTE: Ensure that the actuator's and valve's stems are securely connected in all positions.

If the actuator is forced to travel beyond its end positions, overload protection responds.

Electrical Check

Prior to making the function check, ensure that:

- Actuator is mechanically connected to a Siemens valve.
- Actuator is in Automatic Operation mode.
- Actuator and, if required, accessories are correctly fitted and connected.
- Power is applied.

Calibration (SAX61.03U Only)

Calibration is required with modulating actuators, and before the function check. **Calibration must be performed manually.**

Prior to calibrating, ensure that:

- Actuator is properly connected to a valve.
- Housing cover is removed.
- Power is applied.

If required, calibration can be repeated any number of times.

To initiate the calibration process insert a flat-blade screwdriver into the calibration slot to short out the two sides of the slot. See Figure 19.

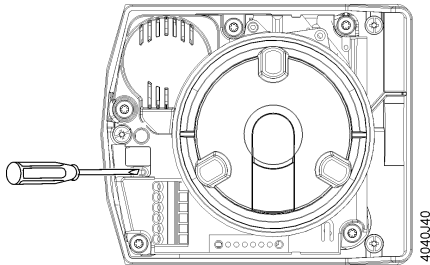
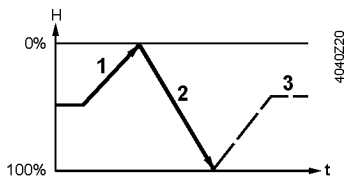

Figure 19. Step 1—Bridge contact.

During calibration, the actuator detects the valve's end positions and files the exact stroke in its internal memory. Calibration takes place in three phases:



- Actuator drives to H_0 (1), retracting actuator stem. Detection of upper end position.
- Actuator drives to H_{100} (2), extending actuator stem. Detection of lower end position.
- The detected values are stored (3). Then the actuator follows the applied control signal.

Observe the status indication (LED) during and after calibration. See Figures Figure 20 and Table 2.

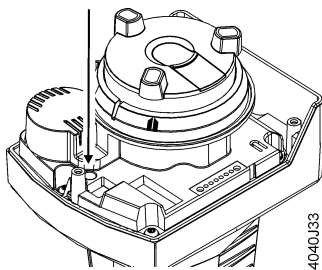

Figure 20. Step 2—Check LED.

Table 2. LED Indication and Status.

LED	Indication	Operating state	Remarks, troubleshooting
Green	On	Automatic mode	Normal operation
	Blinking	Calibration	Wait until calibration is finished (then green or red light)
		In manual mode	Manual adjuster in MAN position
Red	On	Calibration error	Start calibration again
	Blinking	Detection of foreign object	Check valve / actuator
Off	Off	No power or electronics faulty	Check operating voltage

If the actuator does not detect the second end position within an appropriate stroke range (max. 25 mm), the first end stop will be adopted and the actuator operates with a working range of 20 mm.

SAX61.03U Function Check

Perform the function check for modulating actuators after calibration with a point test according to the following table:

Table 3. Modulating Function Check.

Connection Terminals	Actuator Response	Position Feedback (U)
Y 6V 13.6 mA	Actuator's stem extends (60%)	6V
Y 5V 12 mA	Actuator's stem retracts (50%)	5V
"Z" connected to "G"	Actuator's stem extends to 100%	10V
"Z" connected to "G0"	Actuator's stem retracts to 0%	0V

After successful completion of the function check, the actuator is ready for normal operation.

SAX81.03U Function Check

Perform the function check for three-position actuators according to the following table:

Table 4. Three-Position (Floating) Function Check.

Connection Terminals	Actuator Response
Voltage at Y1	Actuator's stem extends
Voltage at Y2	Actuator's stem retracts
No voltage at Y1 and Y2	Actuator's stem maintains the position

After successful completion of the function check, the actuator is ready for normal operation.

Dimensions

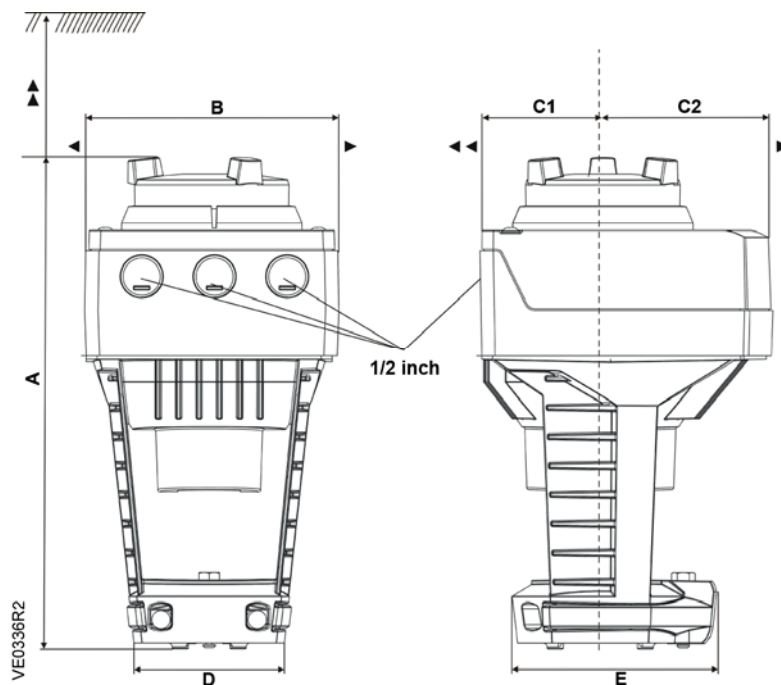

Product Numbers	A	B	C	C1	C2	D	E	▶	▶▶
SAX61.03U SAX81.03U	9.53 (242)	4.88 (124)	5.91 (150)	2.68 (68)	3.23 (82)	3.15 (80)	3.94 (100)	3.94 (100)	7.87 (200)
With ASK39.1	10.51 (267)	6.06 (154)	11.81 (300)	7.87 (200)	3.94 (100)	—	—	—	—

Figure 21. SAX Dimensions in Inches (Millimeters).

Information in this publication is based on current specifications. The company reserves the right to make changes in specifications and models as design improvements are introduced. Flowrite is a registered trademark of Siemens Industry, Inc. Product or company names mentioned herein may be the trademarks of their respective owners. © 2011 Siemens Industry, Inc.

References

Technical Instructions:

Flowrite 599 Series 155-506
 SAX Electronic Valve Actuator Proportional Control

Flowrite 599 Series 155-507
 SAX Electronic Valve Actuator 3-position (floating) Control