

Flowrite™ EA 599 Series

SKD Electronic Valve Actuator 24 Vac Proportional Control

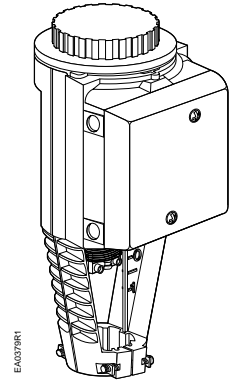

Description

The Flowrite EA 599 Series SKD Electronic Valve Actuator requires a 24 Vac supply and receives a 0 to 10 Vdc or a 4 to 20 mA control signal to proportionally control a valve. This actuator is designed to work with Flowrite VF 599 Series valve and Siemens Building Technologies, Inc. standard valves with a 3/4-inch (20 mm) stroke.

Features

- Direct-coupled installation requires no special tools or adjustments
- Visual and electronic stroke indication
- Die-cast aluminum housing
- Manual override
- Spring return to fail safe position
- Automatic stroke calibration
- Maintenance-free



Application

These electronic actuators are designed to be used with Flowrite VF 599 Series valves and Siemens Building Technologies' standard valves with a 3/4-inch (20 mm) stroke in liquid service and steam service applications.

Product Number

SKD62U (Actuator Prefix Code 274)

Warning/Caution Notations

WARNING		Personal injury/loss of life may occur if a procedure is not performed as specified.
CAUTION		Equipment damage, or loss of data may occur if the user does not follow procedure as specified.

Specifications

Power supply	Operating voltage	24 Vac \pm 20%		
	Frequency	50/60 Hz		
	Power consumption	17 VA		
Control signals	Control input (Y)			
	Voltage	0 to 10 Vdc or 4 to 20 mA (DIP switch selectable)		
	Maximum Impedance	0 to 10 Vdc 100K ohms 4 to 20 mA; 240 ohm		
	Control input (Z)			
	Resistance	0 to 1000 ohms		
	Voltage	0 to 1.6V		
	Control output (U)			
	Voltage	0 to 10 Vdc		
	Load Impedance	>500 ohm		
	Current	4 to 20 mA		
Load impedance	< 500 ohms			
Function	Nominal stroke	3/4-inch (20 mm)		
	Run time with control operation (full stroke)			
	Power stroke, 0 to 100%; 100% to 0%	30 seconds		
	Spring return stroke, 100 to 0%	15 seconds		
	Nominal Force	Stroke	Force	
	NC and 3-way upper	0%	225 lbs. (1000 N)	
NO and 3-way by-pass	100%	258 lbs. (1150 N)		
Agency Certification	UL approval	UL873		
	C-UL	Certified to Canadian standard C22.2 No. 24-93		
	CE conformity per the EMC directive	89/336/EEC		
	Low voltage directive	73/23/EEC		
Ambient conditions	Ambient temperature	5°F to 122°F (-15°C to 50°C)		
	Media temperature	14°F to 284°F (-10°C to 140°C)		
Housing	NEMA Rating	NEMA 1 (interior only) See <i>Accessories</i> .		
Miscellaneous	Dimensions	See Figure 19		
	Conduit opening	1/2-inch NPSM		
	Weight	7.5 lbs. (3.4 kg)		

Accessories

NOTE: Installation instructions are included with each accessory.

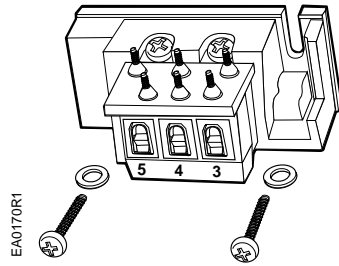

Figure 1. Auxiliary Switch.

ASC1.6 Auxiliary switch.

Sends a signal to indicate the valve is in the 0% stroke position. Switching point is fixed at the 0% stroke position.

Switching capacity 24 Vac
 4A resistive
 2A inductive

Lowest recommended
 current 10 mA

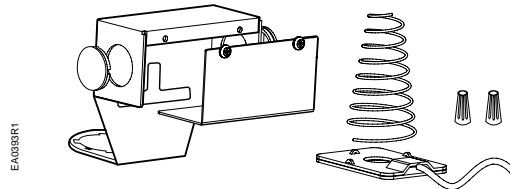

Figure 2. Packing Heating Element.

599-00417 Packing heating element.

Allows stem to move freely in valves controlling fluids at temperatures below 32°F (0°C). Reduces ice crystal formation on the stem which may damage the packing.

Operating Voltage 24 Vac
 Heating Output 20 W

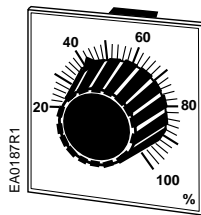

Figure 3. Remote Setting Unit.

FZA21.11 Remote setting unit.

Potentiometer for manual control or remote setting of minimum positions of controlled devices. Suitable for flush panel mounting only.

Control Input 0 to 1000 Ohms

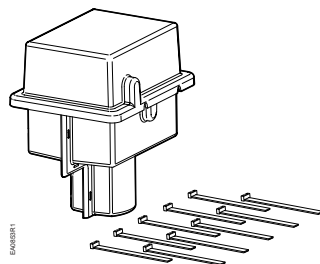

Figure 4. Weather Shield.

599-10071 Weather Shield.

See *Service Kits* for replacement UV resistant cable ties.

Service Kits

The only field serviceable part is the circuit board.

Circuit board replacement	4-668-5748-8
Plastic wiring compartment cover	4-104 5634-8
Manual Override Kit for SKD	4-268 5504-8
Ultraviolet (UV) resistant cable ties (pkg. of 10)	538-996



WARNING:

This product contains a spring under high compression. Do not attempt to disassemble the actuator.

SKD Details

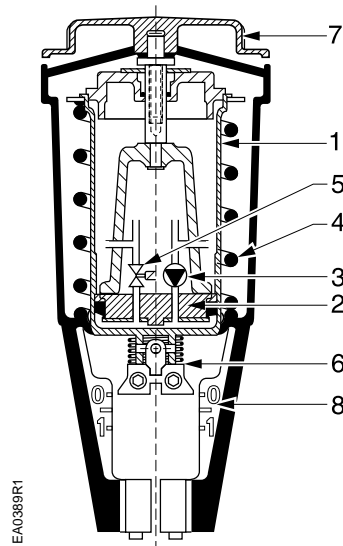

Legend

- 1 Pressure cylinder
- 2 Piston
- 3 Oscillating pump
- 4 Return spring
- 5 Bypass valve
- 6 Valve stem retainer
- 7 Manual override knob
- 8 Position indicator

Figure 5. SKD Details.

Operation

The actuator accepts a 0 to 10 Vdc or a 4 to 20 mA control signal. The actuator mounted on a valve, produces a stroke proportional to the input signal. When power is turned off or in the event of a power failure, the actuator spring returns the valve to its normal position.

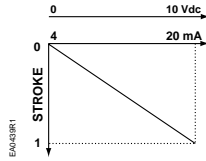

Figure 6.



Figure 7.

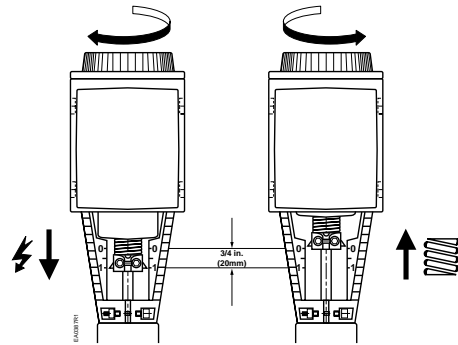

Figure 8. Valve Stem Travel Indication.

Mounting and Installation

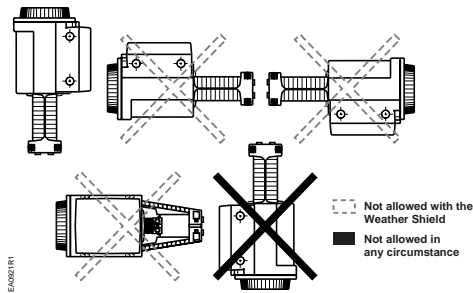

Figure 9. Acceptable Mounting Positions.

The vertical position is the recommended position for mounting. Other positions are allowed. When using the Weather Shield for NEMA 3R rating, the vertical position is required. See Weather Shield installation instructions and Figure 9.

Allow four inches (100 mm) around the sides and back of the actuator and eight inches (200 mm) above and to the front of the actuator.

See dimensions in Figure 19.

Detailed installation instructions for field mounting are shipped with the actuator.

Start-up

Check the wiring for proper connections.

NOTE: The valve body assembly determines the complete assembly action.

Stroke Calibration

To determine the stroke positions 0% and 100% in the valve, calibration is required when the valve/actuator are commissioned for the first time.

The actuator must be mechanically connected to a valve and must have a 24 Vac power supply. The calibration procedure can be repeated as often as necessary.



CAUTION:

Before starting calibration, be sure the manual adjuster is set to **Automatic** to register the actual values.

There is a slot on the printed circuit boards of the the actuators. To initiate the calibration procedure, the contacts inside this slot must be short-circuited, for example, with a screwdriver (See Figure 10).

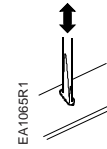

Figure 10.

Automatic calibration proceeds as follows (See Figure 11):

- Actuator runs to the 0 stroke position (1), green LED flashes.
- Actuator then runs to the 100 stroke position (2), green LED flashes.
- Measured values are stored in the EPROM.
- The actuator now moves to the position defined by control signal Y or Z (3), and the green LED now glows steadily (normal operation).
- Throughout this procedure, output U is inactive; meaning, the values only represent actual positions when the green LED stops flashing and remains on continuously.

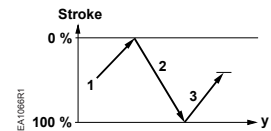

Figure 11.

Table 1. LED Status.

LED	Display	Function	Action
Green	ON	Normal Operation	Automatic operation
	Flashing	Stroke calibration In Progress	Wait for calibration to be completed (LED stops flashing)
Red	ON	Faulty stroke calibration	- Check mounting - Restart stroke calibration (by short-circuiting calibration slot) - Replace electronics
	Flashing	Internal Error	Check the valve
	OFF	<ul style="list-style-type: none"> • No power supply • Faulty electronics 	-Check mains -Replace electronics

Start-up continued

Override Control

The override control input (Z) has three modes of operation:

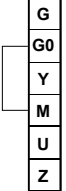
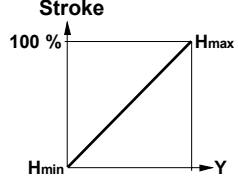
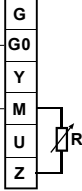
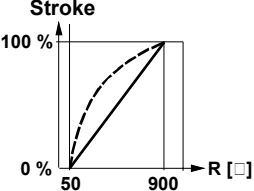
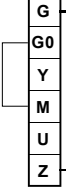
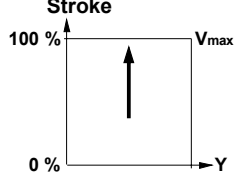
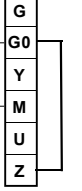
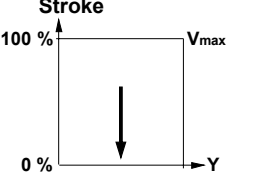
No Function		Override with 0 ... 1000 Ω	
	<p>Stroke</p> 		<p>Stroke</p> 
<p>Z-Contact not Wired Valve Stroke Follows Control Signal Y</p>		<p>Z-Contact Connected to M Via Resistor R Linear or Equal-Percentage Characteristic Starting Position at 50 / End Position at 900 Y-Input has No Effect</p>	
Actuator Fully Extended		Actuator Fully Retracted	
	<p>Stroke</p> 		<p>Stroke</p> 
<p>Z-Contact Connected Directly to G Y-Input has No Effect</p>		<p>Z-Contact Connected Directly to G0 Y-Input has No Effect</p>	

EA1064R1

The Z-modes have a "direct acting" factory setting.

Start-up continued

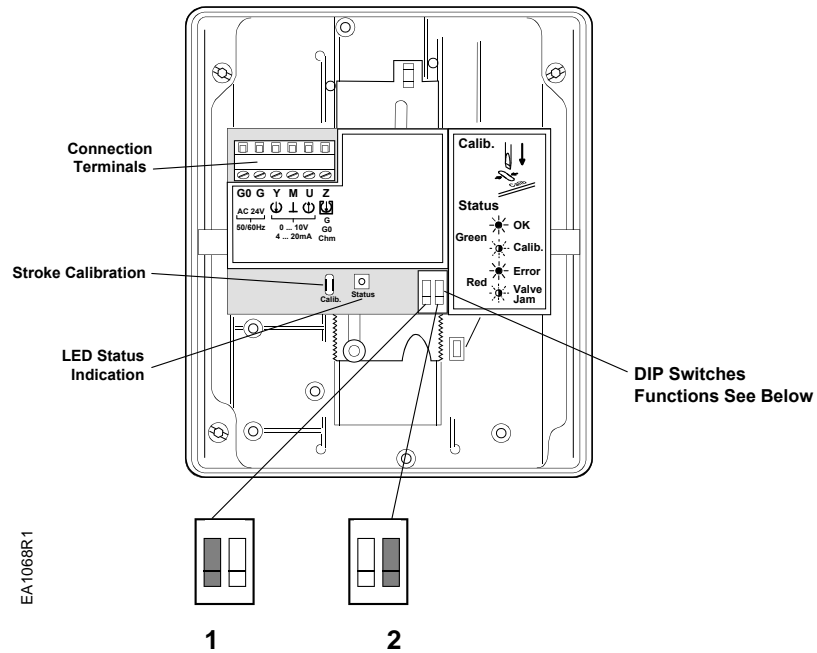

Figure 12. SKD Electronic Features.

DIP Switches (Left to right)	1 Selection of Control Signal	2 Selection of Flow Characteristic
ON	4 to 20 mA	Modified*
OFF Factory Setting	0 to 10 Vdc	Default

*Changing the default setting will modify an equal percentage valve to a linear flow characteristic. When set to default, the flow characteristic is determined by the valve body.

Start-up, continued Actuator pressure cylinder moves:
Normally Closed Valve

- Outward (0 to 1): Valve opens.
- Inward (1 to 0): Valve closes.

Normally Open Valve Actuator pressure cylinder moves:

- Outward (0 to 1): Valve closes.
- Inward (1 to 0): Valve opens.

Three Way Valve Actuator pressure cylinder moves

- Outward (0 to 1): Valve opens between port NC and C.
- Inward (1 to 0): Valve opens between ports NO and C.

The measuring voltage at terminal U provides valve stem position feedback to an indicating instrument or building automation system.

Manual Operation

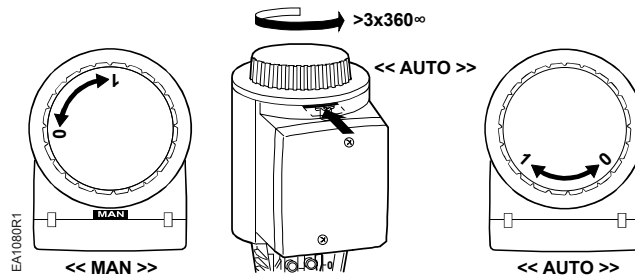

Figure 13. The Manual Setting Knob in Manual and Automatic Position.

- Turn the manual setting knob clockwise for manual operation.
- A red indicator becomes visible as you begin to crank. Each complete revolution (360°) is equal to 3/32-inch (2.5 mm) stroke.
- If a signal is sent to the actuator while it is in manual operation, the actuator will move but the control will not be accurate.
- The valve cannot be commanded to its 0% position while in manual operation.

Automatic operation For automatic operation the manual override knob must be in the fully closed position. Turn the manual override knob counterclockwise until the red indicator disappears.

Wiring

Do not use autotransformers. Use earth ground isolating step-down Class 2 power supplies.

Determine supply transformer rating by summing total VA of all actuators used.

The maximum rating for Class 2 step-down transformer is 100 VA.

- Since SKD62U actuator requires ≈ 20 VA, a maximum of four actuators can be powered by one transformer (80% of transformer VA).
- Operating more than four SKD62U actuators requires additional transformers or separate 100 VA power supplies.
- The position output signal U will switch from 0 to 10 Vdc to 4 to 20 mA when a 4 to 20 mA input signal is selected and used on the Y terminal.

Wiring Diagram

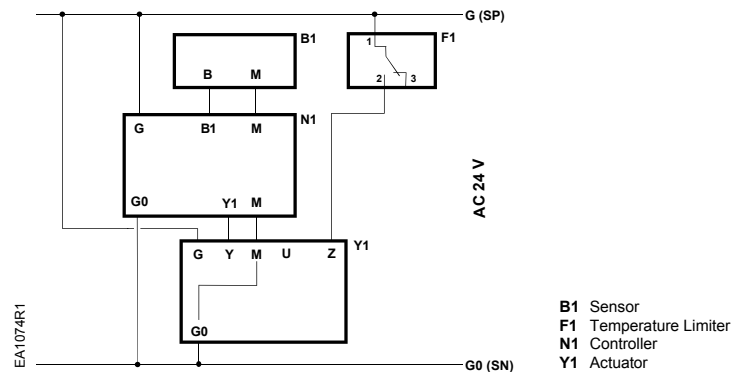

Figure 14. Connecting Terminals.

24 Vac	
G	System Potential (SP)
G0	System Neutral (SN)
Y	Control input 0 to 10 Vdc or 4 to 20 mA (DIP switch selectable)
M	Measuring neutral
U	Position indication 0 to 10 Vdc or 4 to 20 mA, See Table 2.
Z	Override control

Table 2.

Actuator input signal	Receiving Impedance	
	low (<500 Ohm)	high (>10k Ohm)
0 to 10 Vdc	0 to 20 mA	0 to 10 Vdc
4 to 20 mA	4 to 20 mA	2 to 10 Vdc

**Wiring Diagrams,
 continued**

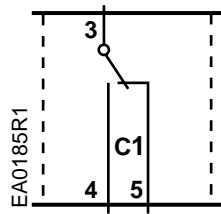

Figure 15. Auxiliary Switch ASC1.6.

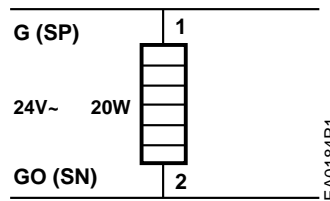

Figure 16. Packing Heating Element 599-00417.

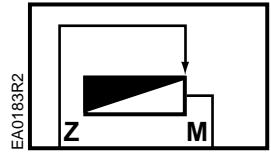

Figure 17. Remote Setting Unit FZA21.11.

Troubleshooting

Check that the wires are connected correctly and attached securely.

Check for adequate power supply.

Check that the actuator is set for automatic operation. See the *Start-Up* section.

Dimensions

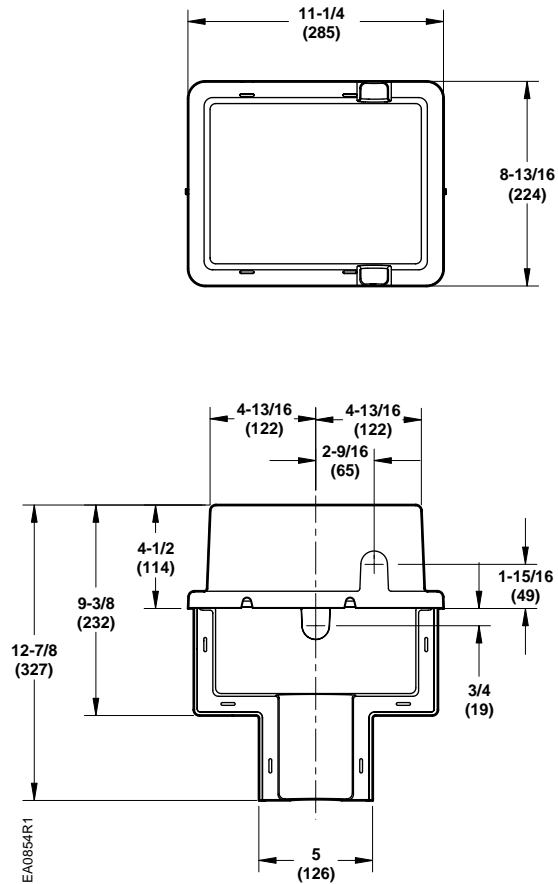

Figure 18. Dimensions of 599-10071 Weather Shield in Inches (Millimeters).

Dimensions, Continued

NOTE: The top knockout position should be used when installing the Weather Shield.

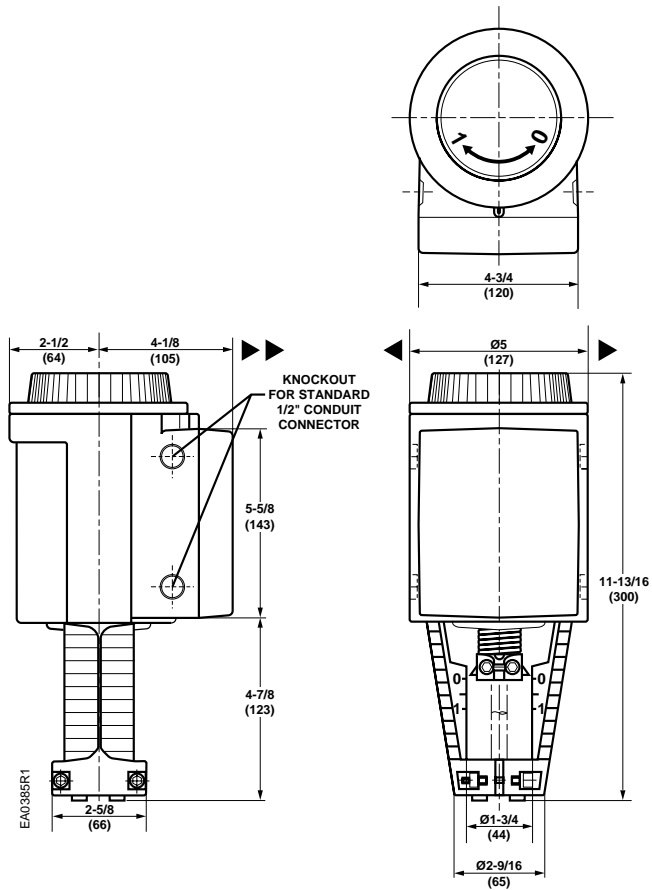

Figure 19. Dimensions of SKD Actuator.

Information in this publication is based on current specifications. The company reserves the right to make changes in specifications and models as design improvements are introduced. Flowrite is a trademark of Siemens Building Technologies, Inc. Other product or company names mentioned herein may be the trademarks of their respective owners. © 2003 Siemens Building Technologies, Inc.