



Thermostatic expansion valves, type TE 5 - TE 55

Contents	Page
Introduction	3
Features	3
Technical data	4
Superheat	4
Ordering:	
R22:	
Thermostatic element	5
Orifice assembly	5
Valve body	5
R407C:	
Thermostatic element	6
Orifice assembly	6
Valve body	6
R134a:	
Thermostatic element	7
Orifice assembly	7
Valve body	7
R404A/R507:	
Thermostatic element	8
Orifice assembly	8
Valve body	8
Capacity:	
R22	9
R407C	11
R134a	12
R404A/R507	13
Design - Function	15
Identification	16
Dimensions and weights	17

Introduction



Thermostatic expansion valves regulate the injection of refrigerant liquid into evaporators. Injection is controlled by the refrigerant superheat.

Therefore the valves are especially suitable for liquid injection in "dry" evaporators where the superheat at the evaporator outlet is proportional to the evaporator load.

Features

- *Large temperature range:*
-76°F to +50°F
Equally applicable to freezing, refrigeration and air conditioning plant.
- *Interchangeable orifice assembly*
 - easier stocking
 - easy capacity matching
 - better service.
- *Stainless steel power element, capillary tube and bulb*
 - high corrosion resistance
 - high strength and vibration resistance
 - fast installation: self-aligning bulb
 - good thermal contact and transmission
- *Rated capacities from 5.5 to 100 TR for R22*
- *Can be supplied with MOP (Max. Operating Pressure)*
Protects the compressor motor against excessive evaporating pressure.
- *Patented double contact bulb*
 - Fast and easy to install.
 - Good temperature transfer from pipe to bulb.

Technical data

Max. temperature
 Bulb, when valve is installed: 212°F
 Complete valve not installed: 140°F

Max. test pressure
 406 psig

Min. temperature
 -76°F

Permissible working pressure
 319 psig

MOP-points

Refrigerant	Range N -40 → +50°F	Range NM -40 → +23°F	Range NL -40 → +5°F	Range B -76 → -13°F
	MOP-point in evaporating temperature t_e and evaporating pressure p_e			
	+60°F	+32°F	+15°F	-4°F
R22	101 psig	57.5 psig	37.8 psig	20.9 psig
R134a	57.4 psig	27.8 psig	15.0 psig	
R404A/R507	124 psig	72.4 psig	49.1 psig	29.0 psig
R407C	94.3 psig			

MOP = Max. Operating Pressure

Superheat

SS = static superheat
 OS = opening superheat
 SH = SS + OS = total superheat
 Q_{nom} = rated capacity
 Q_{max} = maximum capacity

opening begins to where the valve gives its rated capacity Q_{nom} .

Example

Static superheat SS = 9 F
 Opening superheat OS = 11 F
 Total superheat SH = 9 + 11 = 20 F

Static superheat SS can be adjusted with setting spindle.
 The standard superheat setting SS is 9 F for valves without MOP and 7.2 F for valves with MOP.
 The opening superheat OS is 11 F from when

Ordering

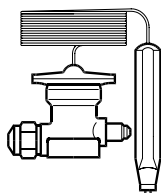

Thermostatic element

R22

Valve type	Pressure equalization $\frac{1}{4}$ in. / 6 mm	Capillary tube feet	Code no.					
			Range N -40 to +50°F		Range NM -40 to +23°F	Range NL -40 to +5°F	Range B -76 to -13°F	
			Without MOP	MOP+59°F	MOP 32°F	MOP 14°F	Without MOP	MOP -4°F
TEX 5	Ext. 1)	9.8	067B3250	067B3267	067B3249	067B3253	067B3263	067B3251
TEX 12	Ext. 2)	9.8	067B3210	067B3227	067B3207	067B3213		067B3211
TEX 12	Ext. 2)	16.4	067B3209					067B3212
TEX 20	Ext. 2)	9.8	067B3274	067B3286	067B3273	067B3275		067B3276
TEX 20	Ext. 2)	16.4	067B3290					067B3287
TEX 55	Ext. 2)	9.8	067G3205	067G3220	067G3206			067G3207
TEX 55	Ext. 2)	16.4	067G3209					067G3217

1) Pressure equalization with solder connector can be supplied on contacting Danfoss.

 2) Available as accessory: solder adapter for TE 12, TE 20 and TE 55. **Code no. 068B0170.**

Orifice assembly

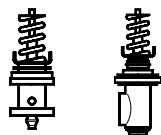

Valve type	Rated capacity Range N: -40 to 50°F TR	Rated capacity Range B: -40 to -13°F TR	Orifice no.	Code no.
TEX 5-3	5.6	3.4	01	067B2089
TEX 5-4.5	7.6	4.8	02	067B2090
TEX 5-7.5	11.1	7.1	03	067B2091
TEX 5-12	15.8	10.1	04	067B2092
TEX 12-4.5	7.6	4.9	01	067B2005
TEX 12-7.5	12.4	8.1	02	067B2006
TEX 12-12	18.3	11.8	03	067B2007
TEX 12-18	24.1	16.0	04	067B2008
TEX 20-30	30.9	20.0	01	067B2172
TEX 55-50	68.3	42.3	01	067G2005
TEX 55-85	101.7	65.1	02	067G2006

The rated capacity is based on:

Evaporating temperature

 $t_e = +41^\circ\text{F}$ for range N and $t_e = -22^\circ\text{F}$ for range B

Condensing temperature

 $t_c = +89.6^\circ\text{F}$

Refrigerant temperature ahead of valve

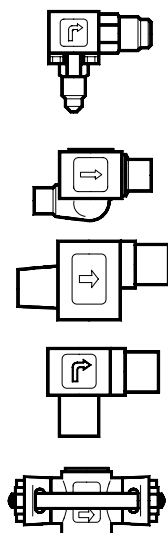
 $t_1 = +82.4^\circ\text{F}$

Valve body

Type	Orifice no.	Connection Inlet x Outlet		Code no.			
		in.	mm	Flare angleway	Solder angleway	Solder straightway	Solder flanges
TE 5	01 - 03	$\frac{1}{2} \times \frac{5}{8}$		067B4013	067B4009	067B4007	
	03	$\frac{1}{2} \times \frac{7}{8}$			067B4010	067B4008	
	04	$\frac{3}{8} \times \frac{7}{8}$			067B4011		
TE 5	01 - 03		12 x 16	067B4013	067B4004	067B4002	
	03		12 x 22		067B4005	067B4003	
	04		16 x 22		067B4012		
TE 12	01 - 02	$\frac{5}{8} \times \frac{7}{8}$			067B4022 1)	067B4020 1)	067B4025 1)
	03 - 04	$\frac{7}{8} \times 1$					067B4026 1)
	03 - 04	$\frac{7}{8} \times 1\frac{1}{8}$			067B4023 2)	067B4021 2)	
TE 12	01 - 02		16 x 22			067B4018 1)	067B4027 1)
	03 - 04		22 x 25				067B4015 1)
	03 - 04		22 x 28		067B4017 2)	067B4016 2)	
TE 20	01	$\frac{7}{8} \times 1\frac{1}{8}$			067B4023 2)	067B4021 2)	
	01		22 x 28		067B4017 2)	067B4016 2)	
TE 55	01 - 02	$1\frac{1}{8} \times 1\frac{3}{8}$			067G4004 3)	067G4003 3)	
	01 - 02		28 x 35		067G4002 3)	067G4001 3)	

1) ODF x ODF

2) ODF x ODM

3) ODM x ODM

ODF = Internal diameter

ODM = External diameter

Ordering
(continued)

R407C

Thermostatic element

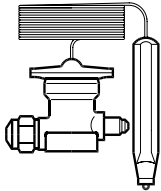

Valve type	Pressure equalization 1/4 in. / 6 mm	Capillary tube feet	Code no.	
			Range N -40 to +50°F	
			Without MOP	MOP+59°F
TEZ 5	Ext. ¹⁾	9.8	067B3278	067B3277
TEZ 12	Ext. ²⁾	9.8	067B3366	067B3367
TEZ 20	Ext. ²⁾	9.8	067B3371	067B3372
TEZ 55	Ext. ²⁾	9.8	067G3240	067G3241

- ¹⁾ Pressure equalization with solder connector can be supplied on contacting Danfoss.
- ²⁾ Available as accessory: solder adapter for TE 12, TE 20 and TE 55.
Code no. 068B0170.

Orifice assembly

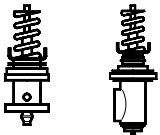

Valve type	Rated capacity Range N: -40 to 50°F TR	Orifice no.	Code no.
TEZ 5-3.2	6.1	01	067B2089
TEZ 5-5.0	8.3	02	067B2090
TEZ 5-8.0	12.0	03	067B2091
TEZ 5-13	17.1	04	067B2092
TEZ 12-5.0	8.3	01	067B2005
TEZ 12-8.0	13.4	02	067B2006
TEZ 12-13	19.7	03	067B2007
TEZ 12-19.5	26.1	04	067B2008
TEZ 20-32.5	33.1	01	067B2172
TEZ 55-54	74.0	01	067G2005
TEZ 55-92	110.0	02	067G2006

The rated capacity is based on:
 Evaporating temperature $t_e = +41^\circ\text{F}$ for range N
 Condensing temperature $t_c = +89.6^\circ\text{F}$
 Refrigerant temperature ahead of valve $t_1 = +82.4^\circ\text{F}$

Valve body

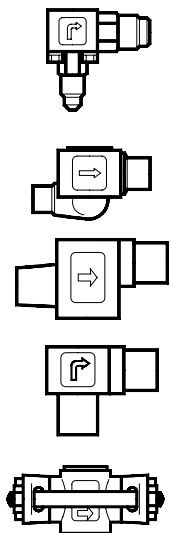

Type	Orifice no.	Connection Inlet x Outlet		Code no.			
		in.	mm	Flare angleway	Solder angleway	Solder straightway	Solder flanges
TE 5	01 - 03	1/2 x 5/8 1/2 x 7/8 5/8 x 7/8		067B4013	067B4009 067B4010 067B4011	067B4007 067B4008	
	03						
	04						
TE 5	01 - 03		12 x 16 12 x 22 16 x 22	067B4013	067B4004 067B4005 067B4012	067B4002 067B4003	
	03						
	04						
TE 12	01 - 02	5/8 x 7/8 7/8 x 1 7/8 x 1 1/8			067B4022 ¹⁾ 067B4023 ²⁾	067B4020 ¹⁾ 067B4021 ²⁾	067B4025 ¹⁾ 067B4026 ¹⁾
	03 - 04						
	03 - 04						
TE 12	01 - 02		16 x 22 22 x 25 22 x 28		067B4017 ²⁾	067B4018 ¹⁾ 067B4016 ²⁾	067B4027 ¹⁾ 067B4015 ¹⁾
	03 - 04						
	03 - 04						
TE 20	01	7/8 x 1 1/8	22 x 28		067B4023 ²⁾ 067B4017 ²⁾	067B4021 ²⁾ 067B4016 ²⁾	
	01						
TE 55	01 - 02	1 1/8 x 1 3/8	28 x 35		067G4004 ³⁾ 067G4002 ³⁾	067G4003 ³⁾ 067G4001 ³⁾	
	01 - 02						

- ¹⁾ ODF x ODF
- ²⁾ ODF x ODM
- ³⁾ ODM x ODM
- ODF = Internal diameter
- ODM = External diameter

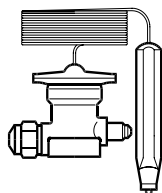
Ordering
 (continued)

Thermostatic element

R134a

Valve type	Pressure equalization $\frac{1}{4}$ in. / 6 mm	Capillary tube feet	Code no.		
			Range N -40 to +50°F		Range NM -40 to 23°F
			Without MOP	MOP +59°F	MOP 32°F
TEN 5	Ext. 1)	9.84	067B3297	067B3298	067B3360
TEN 12	Ext. 2)	9.84	067B3232	067B3233	
TEN 12	Ext. 2)	16.4	067B3363		
TEN 20	Ext. 2)	9.84	067B3292	067B3293	
TEN 20	Ext. 2)	9.84	067B3370		
TEN 55	Ext. 2)	9.84	067G3222	067G3223	
TEN 55	Ext. 2)	9.84	067G3230		

1) Pressure equalization with solder connector can be supplied on contacting Danfoss.

 2) Available as accessory: solder adapter for TE 12, TE 20 and TE 55. **Code no. 068B0170.**

Orifice assembly

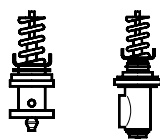

Valve type	Rated capacity TR	Orifice no.	Code no.
TEN 5-3.7	3.7	01	067B2089
TEN 5-5.4	5.5	02	067B2090
TEN 5-8.3	8.3	03	067B2091
TEN 5-11.2	11.3	04	067B2092
TEN 12-4.7	4.8	01	067B2005
TEN 12-7.7	7.8	02	067B2006
TEN 12-11.4	11.4	03	067B2007
TEN 12-15	15.1	04	067B2008
TEN 20-18	18.6	01	067B2170
TEN 55-41	41.4	01	067G2001
TEN 55-62	62.9	02	067G2002

The rated capacity is based on:

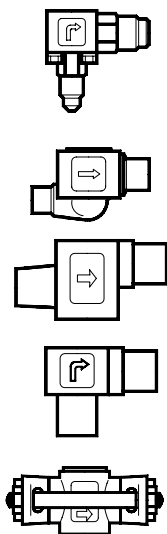
 Evaporating temperature $t_e = +41^\circ\text{F}$
 Condensing temperature $t_c = +89.6^\circ\text{F}$
 Refrigerant temperature ahead of valve $t_i = +82.4^\circ\text{F}$

Valve body

Type	Orifice no.	Connection Inlet x Outlet		Code no.			
		in.	mm	Flare angleway	Solder angleway	Solder straightway	Solder flanges
TE 5	01 - 03	$\frac{1}{2} \times \frac{5}{8}$		067B4013	067B4009	067B4007	
	03	$\frac{1}{2} \times \frac{7}{8}$			067B4010	067B4008	
	04	$\frac{5}{8} \times \frac{7}{8}$			067B4011		
TE 5	01 - 03		12 x 16	067B4013	067B4004	067B4002	
	03		12 x 22		067B4005	067B4003	
	04		16 x 22		067B4012		
TE 12	01 - 02	$\frac{5}{8} \times \frac{7}{8}$			067B4022 1)	067B4020 1)	067B4025 1)
	03 - 04	$\frac{7}{8} \times 1$					067B4026 1)
	03 - 04	$\frac{7}{8} \times 1\frac{1}{8}$			067B4023 2)	067B4021 2)	
TE 12	01 - 02		16 x 22			067B4018 1)	067B4027 1)
	03 - 04		22 x 25				067B4015 1)
	03 - 04		22 x 28		067B4017 2)	067B4016 2)	
TE 20	01	$\frac{7}{8} \times 1\frac{1}{8}$			067B4023 2)	067B4021 2)	
	01		22 x 28		067B4017 2)	067B4016 2)	
TE 55	01 - 02	$1\frac{1}{8} \times 1\frac{3}{8}$			067G4004 3)	067G4003 3)	
	01 - 02		28 x 35		067G4002 3)	067G4001 3)	

1) ODF x ODF

2) ODF x ODM

3) ODM x ODM

ODF = Internal diameter

ODM = External diameter

Ordering
(continued)

Thermostatic element

R404A/R507

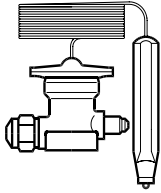

Valve type	Pressure equalization 1/4 in. / 6 mm	Capillary tube feet	Code no.					
			Range N -40 to +50°F		Range NM -40 to 23°F	Range NL -40 to 5°F	Range B -76 to -13°F	
			Without MOP	MOP +59°F	MOP 32°F	MOP 14°F	Without MOP	MOP -4°F
TES 5	Ext. ¹⁾	9.8	067B3342		067B3357	067B3358	067B3344	067B3343
TES 12	Ext. ²⁾	9.8	067B3347		067B3345	067B3348		067B3349
TES 12	Ext. ²⁾	16.4	067B3346					067B3350
TES 20	Ext. ²⁾	9.8	067B3352		067B3351	067B3353		067B3354
TES 20	Ext. ²⁾	16.4	067B3356					067B3355
TES 55	Ext. ²⁾	9.8	067G3302		067G3303	067G3304		067G3305
TES 55	Ext. ²⁾	16.4	067G3301					067G3306

¹⁾ Pressure equalization with solder connector can be supplied on contacting Danfoss.

²⁾ Available as accessory: solder adapter for TE 12, TE 20 and TE 55. **Code no. 068B0170.**

Orifice assembly

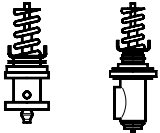

Valve type	Rated capacity range N: -40 to 50°F TR	Rated capacity range B: -76 to -13°F TR	Orifice no.	Code no.
TES 5-3.7	3.7	2.3	01	067B2089
TES 5-5.0	5.1	3.2	02	067B2090
TES 5-7.2	7.2	4.7	03	067B2091
TES 5-10.3	10.3	6.8	04	067B2092
TES12-4.2	4.2	3.3	01	067B2005
TES 12-6.8	6.8	5.4	02	067B2006
TES 12-10.0	10.1	7.9	03	067B2007
TES 12-13.4	13.5	10.7	04	067B2008
TES 20-16.5	16.9	11.7	01	067B2175
TES 55-37.0	37.1	27.1	01	067G2011
TES 55-56.0	56.3	41.1	02	067G2012

The rated capacity is based on:

Evaporating temperature

$t_e = +41^\circ\text{F}$ for range N and $t_e = -22^\circ\text{F}$ for range B

Condensing temperature

$t_c = +89.6^\circ\text{F}$

Refrigerant temperature ahead of valve

$t_1 = +82.4^\circ\text{F}$

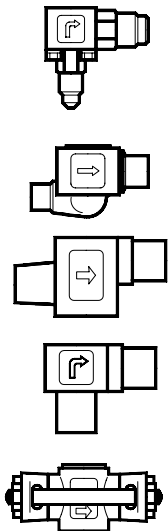

Valve body

Type	Orifice no.	Connection Inlet x Outlet		Code no.			
		in.	mm	Flare angleway	Solder angleway	Solder straightway	Solder flanges
TE 5	01 - 03	1/2 x 5/8		067B4013	067B4009	067B4007	
	03	1/2 x 7/8			067B4010	067B4008	
	04	5/8 x 7/8			067B4011		
TE 5	01 - 03		12 x 16	067B4013	067B4004	067B4002	
	03		12 x 22		067B4005	067B4003	
	04		16 x 22		067B4012		
TE 12	01 - 02	5/8 x 7/8			067B4022 ¹⁾	067B4020 ¹⁾	067B4025 ¹⁾
	03 - 04	7/8 x 1					067B4026 ¹⁾
	03 - 04	7/8 x 1 1/8			067B4023 ²⁾	067B4021 ²⁾	
TE 12	01 - 02		16 x 22			067B4018 ¹⁾	067B4027 ¹⁾
	03 - 04		22 x 25				067B4015 ¹⁾
	03 - 04		22 x 28		067B4017 ²⁾	067B4016 ²⁾	
TE 20	01	7/8 x 1 1/8			067B4023 ²⁾	067B4021 ²⁾	
	01		22 x 28		067B4017 ²⁾	067B4016 ²⁾	
TE 55	01 - 02	1 1/8 x 1 3/8			067G4004 ³⁾	067G4003 ³⁾	
	01 - 02		28 x 35		067G4002 ³⁾	067G4001 ³⁾	

¹⁾ ODF x ODF

²⁾ ODF x ODM

³⁾ ODM x ODM

ODF = Internal diameter

ODM = External diameter

Capacity

Capacity in TR for Range N: -40°F to +50°F

R22

Valve type	Orifice no.	Pressure drop across valve Δp psi								Pressure drop across valve Δp psi							
		29	58	87	116	145	174	203	232	29	58	87	116	145	174	203	232
Evaporating temperature +50°F										Evaporating temperature +32°F							
TEX 5-3	01	3.5	4.6	5.3	5.8	6.2	6.4	6.5	6.5	3.6	4.7	5.4	5.9	6.3	6.5	6.6	6.6
TEX 5-4.5	02	4.9	6.4	7.4	8.0	8.4	8.7	8.8	8.9	5.0	6.5	7.4	8.0	8.5	8.8	9.0	9.0
TEX 5-7.5	03	7.2	9.3	10.6	11.5	12.1	12.5	12.7	12.7	7.4	9.4	10.7	11.5	12.2	12.6	12.8	12.9
TEX 5-12	04	10.2	13.2	15.2	16.4	17.3	17.8	18.1	18.2	10.4	13.4	15.2	16.5	17.4	18.0	18.3	18.4
TEX 12-4.5	01	4.8	6.4	7.4	8.1	8.6	8.9	9.1	9.2	4.6	6.0	7.0	7.6	8.1	8.4	8.6	8.7
TEX 12-7.5	02	7.8	10.3	12.0	13.1	13.9	14.4	14.7	14.8	7.4	9.8	11.3	12.4	13.1	13.6	13.9	14.0
TEX 12-12	03	11.4	15.2	17.5	19.1	20.2	20.9	21.3	21.5	11.0	14.4	16.6	18.2	19.2	20.0	20.4	20.6
TEX 12-18	04	15.1	20.0	23.0	25.0	26.4	27.3	27.8	28.0	14.7	19.2	22.1	24.2	25.6	26.6	27.2	27.5
TEX 20-30	01	20.5	26.8	30.7	33.5	35.3	36.7	37.2	37.5	18.8	24.4	28.0	30.4	32.1	33.5	34.1	34.4
TEX 55-50	01	44.9	59.4	68.5	74.8	79.0	81.6	83.3	83.9	41.2	54.0	62.0	67.4	71.4	73.9	75.3	75.9
TEX 55-85	02	67.9	89.0	102.3	111.2	117.1	120.8	122.8	123.4	62.8	81.3	92.7	100.9	106.6	110.3	112.3	112.9
Evaporating temperature +14°F										Evaporating temperature -4°F							
TEX 5-3	01	3.2	4.1	4.6	5.0	5.3	5.5	5.7	5.7	3.3	3.7	4.0	4.3	4.4	4.5	4.6	4.6
TEX 5-4.5	02	4.4	5.6	6.4	6.9	7.3	7.6	7.8	7.8	4.5	5.1	5.6	5.9	6.1	6.3	6.4	6.4
TEX 5-7.5	03	6.5	8.2	9.3	10.1	10.7	11.2	11.5	11.6	6.6	7.5	8.2	8.7	9.1	9.4	9.5	9.5
TEX 5-12	04	9.2	11.7	13.3	14.5	15.4	16.0	16.4	16.6	9.4	10.7	11.7	12.4	13.0	13.4	13.6	13.6
TEX 12-4.5	01		5.3	6.1	6.7	7.1	7.3	7.5	7.6		4.5	5.1	5.6	5.9	6.1	6.3	6.4
TEX 12-7.5	02		8.6	9.9	10.8	11.4	11.9	12.2	12.3		7.4	8.4	9.1	9.6	10.0	10.3	10.4
TEX 12-12	03		12.7	14.5	15.8	16.8	17.5	17.9	18.1		10.7	12.2	13.3	14.1	14.7	15.1	15.3
TEX 12-18	04		16.8	19.2	21.0	22.4	23.3	24.0	24.3		14.2	16.2	17.7	18.9	19.8	20.4	20.8
TEX 20-30	01		21.4	24.4	26.6	28.2	29.3	30.1	30.4		18.1	20.6	22.4	23.8	24.8	25.6	26.0
TEX 55-50	01		47.2	53.7	58.3	61.7	64.0	65.1	65.7		39.8	44.9	48.6	51.5	53.2	54.3	54.9
TEX 55-85	02		71.4	81.0	87.8	93.0	96.4	98.4	99.2		60.6	68.2	73.9	78.2	81.0	82.7	83.6
Evaporating temperature -22°F										Evaporating temperature -40°F							
TEX 5-3	01		2.6	2.9	3.2	3.3	3.5	3.6	3.6			2.2	2.4	2.6	2.7	2.8	2.8
TEX 5-4.5	02		3.6	4.1	4.4	4.7	4.8	5.0	5.1			3.2	3.4	3.6	3.8	3.9	4.0
TEX 5-7.5	03		5.2	5.9	6.5	6.9	7.2	4.6	7.6			4.6	5.0	5.4	5.7	5.9	6.0
TEX 5-12	04		7.5	8.5	9.2	9.8	10.3	10.7	10.9			6.6	7.2	7.7	8.1	8.4	8.6
TEX 12-4.5	01			4.2	4.5	4.8	5.0	5.1	5.2			3.4	3.6	3.8	4.0	4.1	4.2
TEX 12-7.5	02			6.9	7.4	7.9	8.2	8.4	8.5			5.5	6.0	6.3	6.6	6.7	6.9
TEX 12-12	03			10.0	10.8	11.5	12.1	12.4	12.7			8.0	8.7	9.3	9.7	10.0	10.3
TEX 12-18	04			13.2	14.5	15.5	16.3	16.9	17.3			10.6	11.7	12.6	13.3	13.9	14.3
TEX 20-30	01			16.8	18.3	19.6	20.5	21.2	21.5			13.5	14.7	15.8	16.5	17.2	17.6
TEX 55-50	01			36.7	39.5	41.5	42.9	44.1	44.4			29.0	31.3	33.0	34.1	34.7	35.0
TEX 55-85	02			56.0	60.3	63.7	66.0	67.4	68.2			44.9	48.3	50.6	52.6	53.7	54.3

Capacity (continued)

Capacity in TR for Range B: -76°F to -13°F

R22

Valve type	Orifice no.	Pressure drop across valve Δp psi								Pressure drop across valve Δp psi							
		29	58	87	116	145	174	203	232	29	58	87	116	145	174	203	232
Evaporating temperature -13°F										Evaporating temperature -22°F							
TEX 5-3	01	2.3	2.9	3.3	3.6	3.8	3.9	4.0	4.1	2.0	2.6	2.9	3.2	3.3	3.5	3.6	3.6
TEX 5-4.5	02	3.2	4.0	4.6	4.9	5.3	5.5	5.6	5.7	2.9	3.6	4.1	4.4	4.7	4.8	5.0	5.1
TEX 5-7.5	03	4.7	5.9	6.7	7.3	7.8	8.1	8.4	8.5	4.2	5.2	5.9	6.5	6.9	7.2	7.4	7.6
TEX 5-12	04	6.7	8.4	9.6	10.4	11.1	11.6	12.0	12.2	5.9	7.5	8.5	9.2	9.8	10.3	10.7	10.9
TEX 12-4.5	01	3.2	4.1	4.7	5.1	5.3	5.6	5.7	5.8	2.9	3.7	4.2	4.5	4.8	5.0	5.1	5.2
TEX 12-7.5	02	5.3	6.7	7.6	8.2	8.7	9.1	9.3	9.4	4.8	6.1	6.9	7.4	7.9	8.2	8.4	8.5
TEX 12-12	03	7.6	9.7	11.1	12.0	12.8	13.3	13.7	14.0	6.9	8.8	10.0	10.8	11.5	12.1	12.4	12.7
TEX 12-18	04	10.1	12.9	14.7	16.1	17.2	18.0	18.7	19.0	9.1	11.6	13.2	14.5	15.5	16.3	16.9	17.3
TEX 20-20	01	13.1	16.5	18.8	20.5	21.6	22.7	23.3	23.6	11.7	14.8	16.8	18.5	19.6	20.5	21.0	21.6
TEX 55-35	01	28.4	36.1	40.7	44.1	46.3	48.0	49.2	49.5	25.9	32.7	36.7	39.5	41.5	42.9	44.1	44.4
TEX 55-60	02	43.8	55.2	62.0	67.1	70.8	73.3	75.1	75.9	39.8	49.8	56.0	60.3	63.7	66.0	67.4	68.2
Evaporating temperature -40°F										Evaporating temperature -58°F							
TEX 5-3	01	1.6	2.0	2.2	2.4	2.6	2.7	2.8	2.8		1.6	1.7	1.9	2.0	2.1	2.1	2.2
TEX 5-4.5	02	2.2	2.8	3.2	3.4	3.6	3.8	3.9	4.0		2.2	2.5	2.7	2.8	3.0	3.0	3.1
TEX 5-7.5	03	3.2	4.1	4.6	5.0	5.4	5.7	5.9	6.0		3.2	3.6	4.0	4.2	4.5	4.7	4.8
TEX 5-12	04	4.6	5.8	6.6	7.2	7.7	8.1	8.4	8.6		4.5	5.2	5.7	6.1	6.4	6.7	6.9
TEX 12-4.5	01	2.4	3.0	3.4	3.6	3.8	4.0	4.1	4.2		2.4	2.7	2.9	3.1	3.2	3.3	3.3
TEX 12-7.5	02	3.9	4.9	5.5	6.0	6.3	6.6	6.7	6.9		4.0	4.4	4.8	5.0	5.3	5.4	5.5
TEX 12-12	03	5.6	7.1	8.0	8.7	9.3	9.7	10.0	10.3		5.6	6.4	7.2	7.4	7.8	8.1	8.4
TEX 12-18	04	7.2	9.3	10.6	11.7	12.6	13.3	13.9	14.3		7.4	8.5	9.4	10.2	10.9	11.4	11.8
TEX 20-20	01	9.4	11.9	13.4	14.8	15.6	16.5	17.1	17.6		9.4	10.8	11.9	12.8	13.4	13.9	14.5
TEX 55-35	01	20.8	26.2	29.0	31.3	33.0	34.1	34.7	35.0		20.8	23.0	24.7	25.9	26.7	27.3	27.6
TEX 55-60	02	32.4	40.1	44.9	48.3	50.6	52.6	53.7	54.3		32.1	35.8	38.4	40.4	41.8	42.6	42.9
Evaporating temperature -67°F										Evaporating temperature -76°F							
TEX 5-3	01										1.3	1.4	1.5	1.6	1.7	1.7	1.8
TEX 5-4.5	02										1.8	2.0	2.2	2.3	2.4	2.4	2.5
TEX 5-7.5	03										2.6	2.9	3.2	3.4	3.7	3.8	4.0
TEX 5-12	04										3.7	4.2	4.6	4.9	5.2	5.5	5.6
TEX 12-4.5	01		2.2	2.4	2.6	2.8	2.9	3.0	3.0								
TEX 12-7.5	02		3.6	4.0	4.3	4.5	4.7	4.9	5.0								
TEX 12-12	03		5.1	5.8	6.3	6.7	7.1	7.4	7.6								
TEX 12-18	04		6.6	7.7	8.5	9.3	9.9	10.4	10.9								
TEX 20-20	01		8.5	9.7	10.5	11.4	12.2	12.8	13.1								
TEX 55-35	01		18.8	20.8	22.2	23.3	23.9	24.4	24.7								
TEX 55-60	02		29.0	32.1	34.4	36.1	37.2	38.1	38.4								

Correction for subcooling Δt_{sub}

The evaporator capacities used must be corrected if subcooling deviates from 7.2 F. The corrected capacity can be obtained by

dividing the required evaporator capacity by the correction factor below. Selections can then be made from the tables above.

Note:
Insufficient subcooling can produce flash gas.

Δt _{sub}	7.2 F	18 F	27 F	36 F	45 F	54 F	63 F	72 F	81 F	90 F
Correction factor	1.00	1.06	1.11	1.15	1.2	1.25	1.3	1.35	1.39	1.44

Capacity (continued)

Capacity in TR for Range N: -40°F to +50°F

R407C

Valve type	Orifice no.	Pressure drop across valve Δp psi								Pressure drop across valve Δp psi							
		29	58	87	116	145	174	203	232	29	58	87	116	145	174	203	232
Evaporating temperature +50°F										Evaporating temperature +32°F							
TEZ 5-3.2	01	3.7	4.8	5.5	5.9	6.2	6.3	6.3	6.3	3.8	4.9	5.5	6.0	6.3	6.3	6.4	6.4
TEZ 5-5.0	02	5.1	6.6	7.5	8.1	8.4	8.5	8.6	8.5	5.2	6.7	7.6	8.1	8.5	8.6	8.7	8.6
TEZ 5-8.0	03	7.5	9.6	10.8	11.7	12.1	12.2	12.3	12.2	7.6	9.7	10.9	11.7	12.2	12.3	12.4	12.4
TEZ 5-13	04	10.6	13.6	15.5	16.6	17.3	17.4	17.5	17.4	10.8	13.8	15.5	16.7	17.4	17.6	17.7	17.7
TEZ 12-5.0	01	5.0	6.6	7.6	8.2	8.6	8.8	8.8	8.8	4.7	6.2	7.1	7.7	8.1	8.2	8.4	8.4
TEZ 12-8.0	02	8.1	10.7	12.2	13.2	13.9	14.1	14.2	14.2	7.7	10.1	11.5	12.5	13.1	13.3	13.5	13.4
TEZ 12-13.0	03	11.9	15.6	17.9	19.3	20.2	20.5	20.7	20.6	11.4	14.9	17.0	18.3	19.2	19.6	19.8	19.8
TEZ 12-19.5	04	15.6	20.5	23.6	25.3	26.4	26.7	27.0	26.9	15.3	19.9	22.5	24.4	25.6	26.2	26.4	26.4
TEZ 20-32.5	01	21.3	27.6	31.3	33.8	35.3	35.8	36.1	36.1	19.6	25.3	28.4	30.7	32.1	33.0	33.0	33.0
TEZ 55-54	01	46.6	61.1	69.9	75.6	79.0	79.9	80.7	80.5	42.9	55.7	63.1	67.9	71.4	72.5	73.1	72.8
TEZ 55-92	02	70.8	91.5	104.3	112.3	117.1	118.6	119.1	118.6	65.4	83.9	94.7	102.1	106.6	108.0	108.9	108.3
Evaporating temperature +14°F										Evaporating temperature -4°F							
TEZ 5-3.2	01	3.3	4.2	4.7	5.0	5.3	5.4	5.5	5.4		3.3	3.7	4.0	4.2	4.3	4.4	4.3
TEZ 5-5.0	02	4.5	5.7	6.4	6.9	7.3	7.4	7.5	7.4		4.6	5.2	5.6	5.9	6.0	6.0	6.0
TEZ 5-8.0	03	6.7	8.3	9.4	10.1	7.9	11.0	11.1	11.1		6.7	7.6	8.2	8.6	8.8	9.0	9.0
TEZ 5-13	04	9.6	11.9	13.4	14.5	15.4	15.7	15.9	15.8		9.6	10.8	11.7	12.3	12.6	12.8	12.8
TEZ 12-5.0	01		5.4	6.1	6.7	7.1	7.2	7.3	7.2		4.6	5.2	5.6	5.9	6.0	6.0	6.0
TEZ 12-8.0	02		8.8	10.0	10.8	11.4	11.7	11.8	11.7		7.5	8.4	9.1	9.6	9.7	9.9	9.8
TEZ 12-13.0	03		12.9	14.6	15.8	16.8	17.1	17.3	17.2		10.9	12.3	13.3	14.0	14.2	14.5	14.4
TEZ 12-19.5	04		17.1	19.4	21.0	22.4	22.9	23.3	23.1		14.5	16.4	17.7	18.7	19.2	19.6	19.5
TEZ 20-32.5	01		21.9	24.7	26.7	28.1	28.7	29.3	29.0		18.5	20.8	22.4	23.6	24.1	24.6	24.4
TEZ 55-54	01		48.0	54.3	58.3	61.7	62.8	63.1	62.3		40.7	45.5	48.6	50.9	51.5	52.0	51.5
TEZ 55-92	02		72.8	81.9	87.8	93.0	94.4	95.5	94.4		61.7	68.8	73.9	77.3	78.5	79.3	78.5
Evaporating temperature -22°F										Evaporating temperature -40°F							
TEZ 5-3.2	01		2.6	2.9	3.1	3.3	3.3	3.4	3.4			2.2	2.4	2.4	2.5	2.6	2.6
TEZ 5-5.0	02		3.7	4.1	4.3	4.6	4.6	4.7	4.7			3.2	3.4	3.5	3.6	3.6	3.6
TEZ 5-8.0	03		5.3	6.0	6.4	6.7	6.9	7.1	7.1			4.6	4.9	5.2	5.4	5.5	5.5
TEZ 5-13	04		7.6	8.6	9.2	9.6	9.9	10.1	10.1			6.6	7.1	7.4	7.7	7.8	7.9
TEZ 12-5.0	01			4.2	4.5	4.7	4.8	4.9	4.8			3.4	3.6	3.7	3.8	3.8	3.8
TEZ 12-8.0	02			6.9	7.4	7.7	7.8	8.0	7.9			5.5	5.9	6.1	6.2	6.3	6.3
TEZ 12-13.0	03			10.1	10.7	11.3	11.6	11.8	11.8			8.0	8.5	8.9	9.2	9.3	9.4
TEZ 12-19.5	04			13.4	14.4	15.2	15.7	16.1	16.1			10.5	11.4	11.9	12.5	12.9	13.2
TEZ 20-32.5	01			17.0	18.2	19.2	19.6	20.1	20.0			13.6	14.5	15.1	15.6	16.0	16.2
TEZ 55-54	01			37.0	39.2	40.7	41.2	41.8	41.2			29.0	30.7	31.6	32.4	32.1	32.1
TEZ 55-92	02			56.6	59.7	62.5	63.4	64.0	63.4			44.9	47.5	48.6	50.0	50.0	50.0

Correction for subcooling Δt_{sub}

The evaporator capacities used must be corrected if subcooling deviates from 7.2 F. The corrected capacity can be obtained by

dividing the required evaporator capacity by the correction factor below. Selections can then be made from the tables above.

Note:
Insufficient subcooling can produce flash gas.

Δt _{sub}	7.2 F	18 F	27 F	36 F	45 F	54 F	63 F	72 F	81 F	90 F
Correction factor	1.00	1.08	1.14	1.21	1.27	1.33	1.39	1.45	1.51	1.57

Capacity (continued)

Capacity in TR for Range N: -40°F to +50°F

R134a

Valve type	Orifice no.	Pressure drop across valve Δp bar					Pressure drop across valve Δp bar				
		29	58	87	116	145	29	58	87	116	145
Evaporating temperature +50°F						Evaporating temperature +32°F					
TEN 5-3.7	01	3.0	3.8	4.2	4.4	4.5	2.5	3.2	3.5	3.7	3.8
TEN 5-5.4	02	4.5	5.6	6.2	6.5	6.7	3.8	4.7	5.2	5.5	5.6
TEN 5-8.3	03	6.5	8.0	8.9	9.3	9.5	5.5	6.9	7.7	8.1	8.3
TEN 5-11.2	04	9.2	11.5	12.7	13.3	13.6	7.9	9.9	11.0	11.6	11.9
TEN 12-4.7	01	3.7	4.8	5.4	5.7	5.9	3.2	4.2	4.6	4.9	5.0
TEN 12-7.7	02	6.1	7.8	8.8	9.3	9.5	5.3	6.8	7.6	8.0	8.2
TEN 12-11.4	03	8.9	11.5	12.9	13.6	14.0	7.7	9.9	11.1	11.7	12.0
TEN 12-15	04	11.9	15.3	17.1	18.1	18.6	10.3	13.1	14.7	15.6	16.1
TEN 20-18	01	15.0	19.1	21.2	22.4	22.9	13.0	16.3	18.3	19.3	19.8
TEN 55-41	01	33.3	36.4	47.5	50.0	51.2	28.7	36.4	40.4	42.6	43.5
TEN 55-62	02	50.6	64.3	71.4	75.1	76.8	44.1	55.4	61.4	64.5	66.0
Evaporating temperature +14°F						Evaporating temperature -4°F					
TEN 5-3.7	01	2.0	2.5	2.8	2.9	3.0	1.6	1.9	2.1	2.2	2.3
TEN 5-5.4	02	3.0	3.8	4.2	4.4	4.5	2.4	2.9	3.2	3.4	3.5
TEN 5-8.3	03	4.4	5.5	6.1	6.5	6.7	3.4	4.2	4.7	5.1	5.2
TEN 5-11.2	04	6.3	7.8	8.8	9.3	9.6	4.9	6.1	6.8	7.2	7.4
TEN 12-4.7	01	2.7	3.4	3.8	4.1	4.2	2.2	2.8	3.1	3.2	3.3
TEN 12-7.7	02	4.5	5.6	6.3	6.6	6.8	3.6	4.5	5.0	5.3	5.4
TEN 12-11.4	03	6.5	8.2	9.1	9.7	9.9	5.2	6.5	7.3	7.8	8.0
TEN 12-15	04	8.6	10.8	12.1	12.9	13.3	6.9	8.6	9.7	10.4	10.8
TEN 20-18	01	10.8	13.5	15.1	16.0	16.4	8.7	10.8	12.1	12.9	13.2
TEN 55-41	01	24.1	30.1	33.3	35.0	35.5	19.5	24.0	26.5	27.8	28.3
TEN 55-62	02	37.0	45.8	50.9	53.4	54.6	30.1	37.0	40.7	42.9	43.5
Evaporating temperature -22°F						Evaporating temperature -40°F					
TEN 5-3.7	01	1.2	1.4	1.6	1.7	1.8	0.9	1.1	1.3	1.3	1.3
TEN 5-5.4	02	1.8	2.2	2.5	2.6	2.7	1.4	1.7	1.9	2.0	2.1
TEN 5-8.3	03	2.6	3.2	3.6	3.9	4.0	2.0	2.5	2.8	3.0	3.1
TEN 5-11.2	04	3.8	4.6	5.2	5.5	5.7	2.9	3.6	4.0	4.3	4.5
TEN 12-4.7	01	1.8	2.2	2.4	2.6	2.6	1.4	1.8	1.9	2.0	2.1
TEN 12-7.7	02	2.9	3.6	4.0	4.2	4.3	2.4	2.9	3.2	3.3	3.4
TEN 12-11.4	03	4.2	5.1	5.7	6.1	6.3	3.3	4.1	4.6	4.9	5.0
TEN 12-15	04	5.4	6.7	7.6	8.2	8.6	4.3	5.3	6.1	6.6	6.9
TEN 20-18	01	6.9	8.5	9.5	10.2	10.5	5.5	6.8	7.6	8.2	8.5
TEN 55-41	01	15.6	18.9	20.8	21.7	22.0	12.6	15.1	16.5	17.2	17.4
TEN 55-62	02	24.1	29.3	32.1	33.5	34.1	19.6	23.5	25.6	26.8	27.1

Correction for subcooling Δt_{sub}

The evaporator capacities used must be corrected if subcooling deviates from 7.2 F. The corrected capacity can be obtained by

dividing the required evaporator capacity by the correction factor below. Selections can then be made from the tables above.

Note:
Insufficient subcooling can produce flash gas.

Δt_{sub}	7.2 F	18 F	27 F	36 F	45 F	54 F	63 F	72 F	81 F	90 F
Correction factor	1.00	1.08	1.13	1.19	1.25	1.31	1.37	1.42	1.48	1.54

Capacity (continued)

Capacity in TR for Range N: -40°F to +50°F

R404A/R507

Valve type	Orifice no.	Pressure drop across valve Δp psi								Pressure drop across valve Δp psi							
		29	58	87	116	145	174	203	232	29	58	87	116	145	174	203	232
Evaporating temperature +50°F										Evaporating temperature +32°F							
TES 5-3.7	01	2.8	3.6	4.1	4.3	4.4	4.5	4.5	4.5	2.7	3.4	3.9	4.1	4.2	4.2	4.2	4.2
TES 5-5.0	02	3.9	4.9	5.5	5.8	6.0	6.0	6.1	6.1	3.7	4.7	5.3	5.6	5.7	5.7	5.7	5.7
TES 5-7.2	03	5.7	7.1	7.9	8.3	8.5	8.6	8.6	8.6	5.5	6.9	7.8	8.2	8.4	8.4	8.4	8.4
TES 5-10.3	04	8.0	10.2	11.3	11.9	12.2	12.3	12.4	12.4	7.8	9.9	11.1	11.8	12.1	12.1	12.1	12.0
TES 12-4.2	01	3.4	4.4	5.0	5.3	5.5	5.6	5.6	5.6	2.9	3.8	4.3	4.6	4.7	4.8	4.8	4.8
TES 12-6.8	02	5.5	7.2	8.1	8.6	8.9	9.0	9.1	9.1	4.8	6.3	7.1	7.5	7.7	7.8	7.8	7.8
TES 12-10.0	03	8.1	10.5	11.9	12.7	13.1	13.2	13.4	13.4	7.0	9.2	10.3	11.0	11.3	11.4	11.5	11.5
TES 12-13.4	04	10.8	14.0	15.8	16.8	17.4	17.7	17.8	17.9	9.4	12.2	13.8	14.7	15.2	15.3	15.4	15.5
TES 20-16.7	01	13.6	17.6	19.6	20.8	21.3	21.6	21.9	21.9	11.9	15.1	17.1	18.2	18.8	18.8	18.8	18.8
TES 55-37	01	30.1	38.9	43.8	46.6	48.0	48.3	48.6	48.6	26.2	33.8	38.1	40.4	41.2	41.5	41.2	41.2
TES 55-56.0	02	45.8	59.1	66.0	69.7	71.6	72.2	72.5	72.5	40.1	51.5	57.7	60.8	62.3	62.3	62.3	62.0
Evaporating temperature +14°F										Evaporating temperature -4°F							
TES 5-3.7	01	2.2	2.9	3.2	3.4	3.5	3.5	3.5	3.5		2.2	2.5	2.7	2.8	2.8	2.8	2.8
TES 5-5.0	02	3.1	4.0	4.4	4.7	4.8	4.8	4.8	4.8		3.1	3.5	3.8	3.9	3.9	3.9	3.8
TES 5-7.2	03	4.5	5.8	6.5	7.0	7.1	7.2	7.2	7.2		4.6	5.2	5.6	5.8	5.9	5.9	5.9
TES 5-10.3	04	6.5	8.3	9.4	10.0	10.2	10.3	10.3	10.3		6.6	7.4	8.1	8.3	8.4	8.4	8.4
TES 12-4.2	01	2.6	3.3	3.8	4.0	4.1	4.1	4.1	4.1		1.8	3.1	3.3	3.4	3.4	3.4	3.3
TES 12-6.8	02	4.2	5.4	6.1	6.5	6.7	6.7	6.7	6.6		4.5	5.1	5.4	5.6	5.6	5.5	5.5
TES 12-10.0	03	6.1	7.9	9.0	9.6	9.9	9.9	9.9	9.8		6.5	7.4	8.0	8.2	8.3	8.3	8.2
TES 12-13.4	04	8.1	10.5	12.0	12.8	13.3	13.4	13.4	13.4		8.6	9.8	10.7	11.1	11.3	11.3	11.4
TES 20-16.7	01	10.2	13.1	14.8	15.9	16.2	16.5	16.5	16.2		10.8	12.2	13.4	13.6	13.9	13.9	13.6
TES 55-37	01	22.7	29.3	32.7	34.7	35.5	35.5	35.0	34.7		23.9	26.7	28.7	29.3	29.3	28.7	28.4
TES 55-56.0	02	35.3	44.6	50.0	52.9	54.0	54.0	53.4	52.9		36.7	41.2	44.1	44.9	44.9	44.4	43.5
Evaporating temperature -22°F										Evaporating temperature -40°F							
TES 5-3.7	01			2.0	2.1	2.2	2.2	2.1	2.1			1.4	1.6	1.6	1.6	1.6	1.6
TES 5-5.0	02			2.8	2.9	3.0	3.0	3.0	3.0			2.0	2.2	2.3	2.3	2.2	2.2
TES 5-7.2	03			4.1	4.4	4.6	4.7	4.6	4.6			3.0	3.3	3.5	3.6	3.6	3.5
TES 5-10.3	04			5.8	6.3	6.6	6.7	6.6	6.6			4.3	4.7	5.0	5.1	5.1	5.0
TES 12-4.2	01			2.5	2.6	2.7	2.7	2.7	2.6			1.9	2.0	2.1	2.1	2.1	2.0
TES 12-6.8	02			4.1	4.3	4.5	4.5	4.5	4.4			3.2	3.4	3.5	3.5	3.4	3.4
TES 12-10.0	03			5.9	6.4	6.7	6.7	6.7	6.7			4.6	4.9	5.2	5.3	5.3	5.2
TES 12-13.4	04			7.9	8.6	9.1	9.3	9.4	9.4			6.1	6.8	7.2	7.4	7.5	7.5
TES 20-16.7	01			10.0	10.5	11.1	11.4	11.4	11.1			7.7	8.2	8.8	8.8	8.8	8.8
TES 55-37	01			21.3	22.7	23.3	23.0	22.7	22.2			16.5	17.3	17.6	17.6	17.1	16.8
TES 55-56.0	02			33.0	35.0	36.1	35.8	35.3	34.4			25.6	27.0	27.6	27.6	26.7	26.2

Capacity (continued)

Capacity in TR for Range B: -76°F to -13°F

R404A/R507

Valve type	Orifice no.	Pressure drop across valve Δp psi								Pressure drop across valve Δp psi							
		29	58	87	116	145	174	203	232	29	58	87	116	145	174	203	232
Evaporating temperature -13°F										Evaporating temperature -22°F							
TES 5-3.7	01	2.3	2.4	2.4	2.6	2.6	2.7	2.7	2.7	2.2	2.3	2.4	2.4	2.5	2.6	2.6	2.6
TES 5-5.0	02	3.4	3.6	3.7	3.8	4.2	4.3	4.5	4.5	3.2	3.3	3.5	3.6	3.8	4.0	4.2	4.2
TES 5-7.2	03	5.6	5.8	6.1	6.3	6.9	7.1	7.3	7.4	5.1	5.2	5.3	5.6	5.9	6.2	6.5	6.7
TES 5-10.3	04	5.7	6.8	7.4	7.7	7.8	8.0	8.1	8.2	5.1	6.3	7.1	7.1	7.2	7.4	7.5	7.5
TES 12-4.2	01	2.8	3.6	3.9	4.2	4.3	4.4	4.4	4.5	2.7	3.2	3.5	3.7	3.8	3.8	3.9	4.0
TES 12-6.8	02	5.2	6.0	6.5	7.1	7.3	7.3	7.4	7.5	4.7	5.3	5.7	6.1	6.3	6.3	6.4	6.5
TES 12-10.0	03	8.7	10.0	10.6	11.9	12.1	12.2	12.3	12.4	7.9	8.7	9.6	10.2	10.4	10.5	10.6	10.8
TES 12-13.4	04	9.8	11.4	12.2	13.4	13.8	13.9	14.0	14.0	8.7	9.8	10.7	11.5	11.6	11.8	11.8	12.0
TES 20-11.7	01	9.7	11.7	13.1	14.2	14.5	14.8	15.1	15.1	8.5	10.5	11.4	12.2	12.8	12.8	13.1	13.4
TES 55-27.0	01	20.2	25.9	27.6	29.6	31.0	31.0	31.6	31.8	17.9	22.5	24.4	26.4	26.7	27.0	27.3	27.3
TES 55-41.0	02	31.6	39.8	41.8	45.8	48.3	48.6	49.5	49.8	28.1	35.3	37.5	40.7	41.2	41.5	41.8	42.4
Evaporating temperature -40°F										Evaporating temperature -58°F							
TES 5-3.7	01		1.8	1.9	1.9	2.0	2.0	2.1	2.1		1.3	1.3	1.3	1.4	1.4	1.4	1.5
TES 5-5.0	02		2.8	2.9	2.9	3.0	3.1	3.2	3.2		2.2	2.2	2.3	2.4	2.4	2.4	2.4
TES 5-7.2	03		4.0	4.1	4.2	4.3	4.5	4.6	4.7		2.9	3.0	3.0	3.0	3.1	3.2	3.2
TES 5-10.3	04		5.0	5.5	5.7	5.8	6.0	6.0	6.0		3.8	4.3	4.4	4.5	4.5	4.5	4.4
TES 12-4.2	01		2.6	2.7	2.8	3.0	3.0	3.1	3.1		2.0	2.1	2.2	2.2	2.3	2.3	2.4
TES 12-6.8	02		4.2	4.5	4.6	4.7	4.8	4.9	5.0		3.2	3.4	3.5	3.7	3.7	3.8	3.8
TES 12-10.0	03		7.0	7.7	7.7	8.0	8.1	8.2	8.3		5.5	5.8	6.0	6.2	6.2	6.3	6.5
TES 12-13.4	04		7.9	8.4	8.7	9.1	9.1	9.2	9.3		6.2	6.6	6.8	6.9	7.1	7.1	7.2
TES 20-11.7	01		8.8	9.4	9.7	9.7	10.0	10.0	10.0		7.4	7.4	7.7	7.7	7.7	8.0	8.0
TES 55-27.0	01		17.9	19.0	19.9	20.8	21.0	21.3	21.6		13.1	13.6	14.2	14.5	14.8	15.1	15.4
TES 55-41.0	02		27.9	30.1	30.7	32.4	32.7	32.7	33.0		21.0	22.2	22.5	23.0	23.3	23.3	23.6
Evaporating temperature -67°F										Evaporating temperature -76°F							
TES 5-3.7	01											0.9	0.9	1.0	1.0	1.0	1.0
TES 5-5.0	02											1.9	1.9	2.0	2.0	2.0	2.1
TES 5-7.2	03											2.2	2.2	2.3	2.3	2.3	2.3
TES 5-10.3	04											3.3	3.4	3.5	3.5	3.5	3.4
TES 12-4.2	01			1.8	2.0	2.0	2.0	2.1	2.2								
TES 12-6.8	02			3.0	3.1	3.2	3.2	3.2	3.3								
TES 12-10.0	03			5.1	5.3	5.4	5.5	5.5	5.6								
TES 12-13.4	04			5.7	5.8	5.9	6.1	6.1	6.3								
TES 20-11.7	01			6.8	6.8	7.1	7.1	7.4	7.4								
TES 55-27.0	01			11.1	11.1	11.7	11.7	11.9	11.9								
TES 55-41.0	02			17.9	18.2	18.5	18.5	18.8	18.8								

Correction for subcooling Δt_{sub}

The evaporator capacities used must be corrected if subcooling deviates from 7.2 F. The corrected capacity can be obtained by

dividing the required evaporator capacity by the correction factor below. Selections can then be made from the tables above.

Note:
Insufficient subcooling can produce flash gas.

Δt _{sub}	7.2 F	18 F	27 F	36 F	45 F	54 F	63 F	72 F	81 F	90 F
Correction factor	1.00	1.1	1.2	1.29	1.37	1.46	1.54	1.63	1.7	1.78

Design/Function

General

TE 5 and TE 55 valves have an interchangeable orifice assembly.

TE 5 and TE 55 valves are built up of three interchangeable main components:

- I. Thermostatic element, 1
- II. Orifice assembly, 2
- III. Valve body with connections, 3

For the same valve type and refrigerant, the associated orifice assembly is suitable for all versions of valve body and in all evaporating temperature ranges.

The charge in the thermostatic element depends on the evaporating temperature range. The valves are equipped with external pressure equalization.

External pressure equalization should always be used on systems with liquid distributors.

The double contact bulb gives fast and precise reaction to temperature changes in the evaporator. It also makes fitting the bulb quick and easy.

The valves are able to withstand the effects that normally occur with hot gas defrosting.

To ensure long operating life, the valve cone and seat are made of a special alloy with particularly good wear qualities.

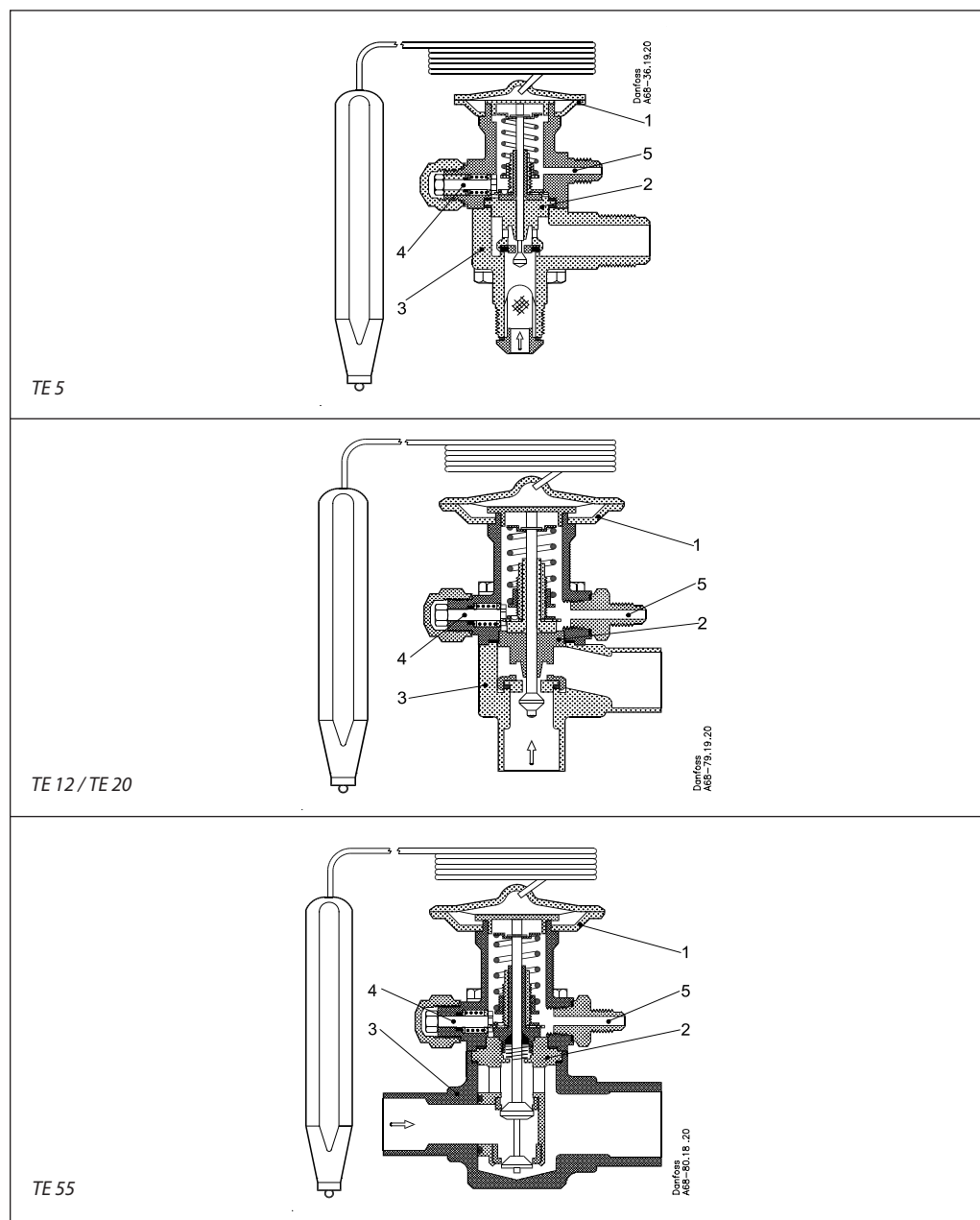

- 1. Thermostatic element (diaphragm)
- 2. Interchangeable orifice assembly
- 3. Valve body
- 4. Superheat setting spindle (see instructions)
- 5. Ext. pressure equalizing connection with 1/4 in. / 6 mm flare nut

Identification

The thermostatic element is fitted with a label (on top of the diaphragm). The code refers to the refrigerant for which the valve is designed:

- X = R22
- N = R134a
- S = R404A/R507
- Z = R407C

The label gives valve type, evaporating temperature range, MOP point, refrigerant, and max. test pressure, PS.

With TE 20 and TE 55 the rated capacity is stamped on a band label fastened to the valve

Orifice assembly for TE 5, TE 12, 20 and 55

The orifice assembly is marked on top of the spring cup, e.g. as shown in the figure. For a given size of valve, the same orifice assembly can be used for valves with ranges N and B.

The thermostatic elements are different however:

- *On TE 5 and TE 12*
the upper stamp (TE 12) indicates for which valve type the orifice can be used. The lower stamp (01) is the orifice size.
- *On TE 20 and TE 55*
the upper stamp (N/B 50/35 TR) indicates the rated capacity in the two evaporating temperature ranges N and B, and the refrigerant. (50/35 TR = 175 kW in range N and 123 kW in range B).
The lower stamp (TEX 55) refers to the valve type for which the assembly can be used.

Capillary tube label for TE 5 to TE 55

The label gives the orifice size (04). A new label always accompanies a new orifice assembly.

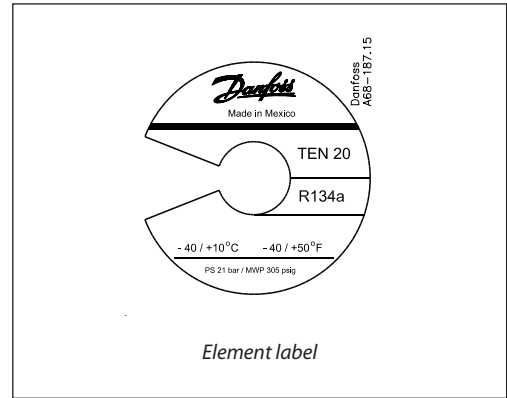

Element label

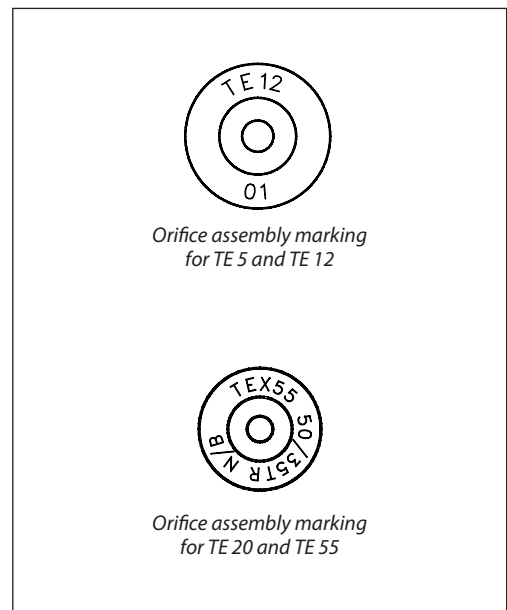

Orifice assembly marking for TE 5 and TE 12

Orifice assembly marking for TE 20 and TE 55

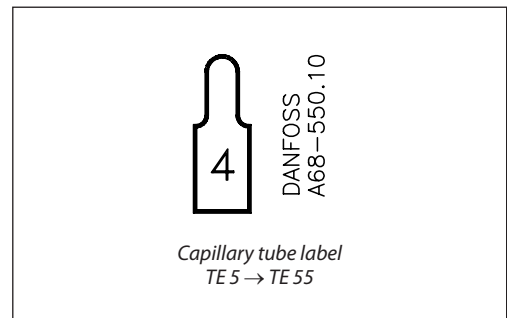

Capillary tube label TE 5 → TE 55

Dimensions and weights

TE 5

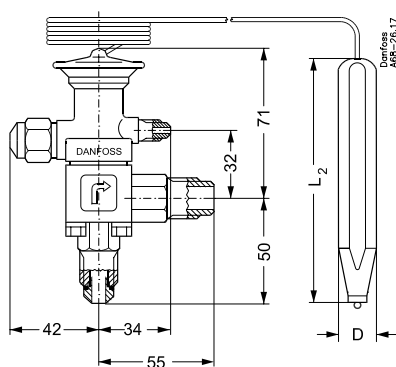

TE 5 - Flare, angleway
Weight: 2.4 lb

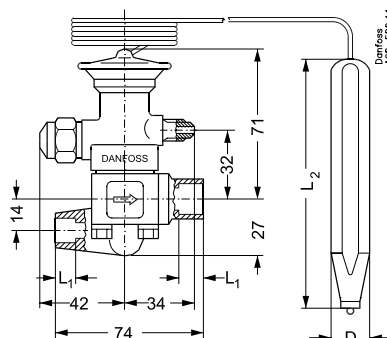

TE 5 - Solder, straightway
Weight: 2.2 lb

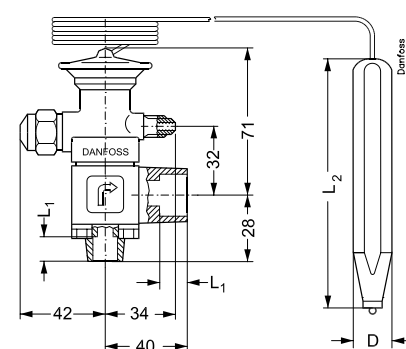

TE 5 - Solder, angleway
Weight: 2.2 lb

TE 5

Inlet side ØD ₁	L ₁ in.
1/2 in. / 12 mm ODF	0.4
3/8 in. / 16 mm ODF	0.4

Outlet side ØD ₂	L ₁ in.
3/8 in. / 16 mm ODF	0.5
7/8 in. / 22 mm ODF	0.7

TE 5

	L ₂	D
Range N	4.5	Ø0.6
Range B	4.4	Ø0.8

Dimensions and weights
(continued)

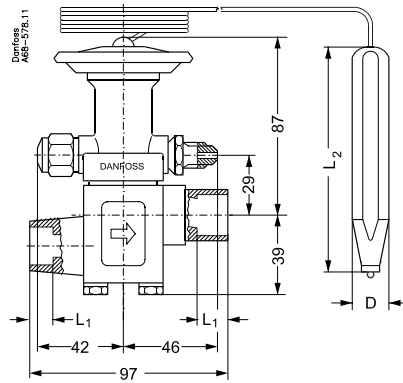

TE 12 and 20 - Solder, straightway
Weight: TE 12: 3.3 lb
TE 20: 3.7 lb

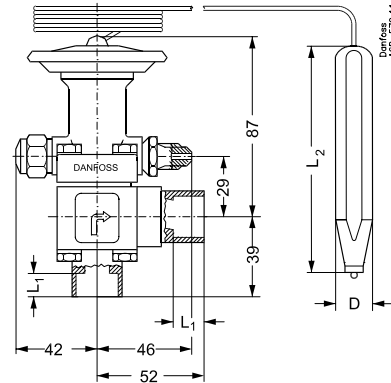

TE 12 and 20 - Solder, angleway
Weight: TE 12: 3.3 lb
TE 20: 3.5 lb

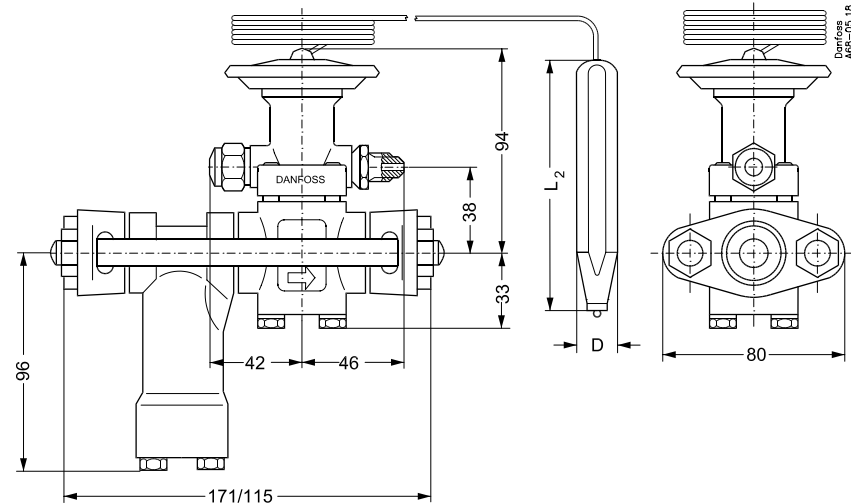

TE 12 - Solder flanges, straightway
Weight: Without filter: 5.1 lb
With filter: 7.0 lb

TE 12 and TE 20

Inlet side ØD ₁	L ₁ in.
5/8 in. / 16 mm ODF	0.5
7/8 in. / 22 mm ODF	0.7

Outlet side ØD ₂	L ₁ in.
7/8 in. / 22 mm ODF	0.7
1 1/8 in. / 28 mm ODM	1.0

Bulb - TE 12

	L ₂	D
Range N	4.4	Ø0.8
Range B	5.8	Ø0.8

Bulb - TE 20

	L ₂	D
Range N/B	5.8	Ø0.8

Dimensions and weights
(continued)

TE 55 - Solder, straightway
Weight: 3.7 lb

TE 55 - Solder, straightway
Weight: 3.5 lb

Type TE 55

Inlet side ØD ₁	L ₁ in.
7/8 in. / 22 mm ODF	0.7
1 1/8 in. / 28 mm ODM	1.0

Outlet side ØD ₂	L ₁ in.
1 1/8 in. / 28 mm ODF	0.9
1 3/8 in. / 35 mm ODM	1.1

Bulb - TE 55

	L ₂	D
Range N/B	5.8	Ø0.8

