

220 SERIES

Pilot Loaded Design

The 220 series uses a servo-operated design rather than a spring-loaded design and can deliver higher outlet pressures than conventional spring-loaded models.

The main diaphragm of the model 220 is loaded with gas pressure instead of spring pressure. A small pilot regulator, located in the upper housing, accurately controls this gas pressure. When the regulated outlet pressure of the servo regulator is changed by spring adjustment, the outlet pressure of the 220 main regulator will be changed proportionately. Applications include industrial furnaces and ovens.



220 D

Specifications

Pipe Sizes 1" to 3" threaded connections with NPT or ISO7-1 threads. 4" 125 lb. flange (220J only).

Housing Material 220D, 220E, 220G, 220J: aluminum.

Mounting Mount in an upright position only.

NOTE: All Maxitrol gas pressure regulators should be installed and operated in accordance with Maxitrol Safety Warning Instructions (see GPR_MI_EN.ES).

Gas Types Suitable for natural, manufactured, mixed gases, liquefied petroleum gases, and LP gas-air mixtures.

Maximum Inlet Pressure 10 psi (68.9 kPa)

Flow Rates up to 50,000 CFH (1416 m³/h)

Emergency Exposure Limits 25 psi (170 kPa)

Ambient Temperature Ranges -40 to 200°F (-40 to 93°C)

Sensing Taps Three positions can be tapped and plugged for measuring pressure. The fourth position is used to supply inlet pressure to the pilot regulator.

Remote Sensing 220D, 220E, 220G models may be ordered with remote sensing. The internal sensing tube is omitted and external sensing taps are provided. Add suffix letter "R" to model number when ordering.

NOTE: 220D, 220E, 220G, 220J are not CSA certified.

NOTE: "L" models available for outlet pressures under 1 psi (6.9 kPa).

Pressure Drop: inches w.c. (kPa) @ 0.64 sp gr gas

Flow Rate CFH (m ³ /h)	220D			220E		220G		220J
	1"	1 1/4"	1 1/2"	1 1/2"	2"	2 1/2"	3"	4"
1000 (28.3)	1.90 (0.47)	1.70 (0.42)	1.70 (0.42)	---	---	---	---	---
2000 (56.6)	4.93 (1.23)	3.10 (0.77)	2.90 (0.72)	1.90 (0.47)	1.90 (0.47)	---	---	---
3000 (85.0)	11.10 (2.76)	7.42 (1.85)	5.40 (1.34)	2.90 (0.72)	2.40 (0.60)	---	---	---
4000 (113)	19.70 (4.91)	13.20 (3.29)	11.10 (2.76)	4.93 (1.23)	4.00 (1.00)	2.00 (0.50)	1.90 (0.47)	1.70 (0.42)
5000 (142)	30.80 (7.67)	20.70 (5.16)	17.40 (4.33)	7.70 (1.92)	6.25 (1.56)	2.20 (0.55)	2.10 (0.52)	1.70 (0.42)
6000 (170)	44.20 (11.01)	29.70 (7.40)	25.00 (6.23)	11.10 (2.76)	9.00 (2.24)	2.60 (0.65)	2.30 (0.57)	1.70 (0.42)
7000 (198)	---	40.60 (10.11)	34.00 (8.47)	15.10 (3.76)	12.25 (3.05)	3.00 (0.75)	2.60 (0.65)	1.70 (0.42)
8000 (226)	---	---	44.50 (11.08)	19.70 (4.91)	16.00 (3.98)	4.00 (1.00)	3.00 (0.75)	1.80 (0.45)
9000 (255)	---	---	---	24.90 (6.20)	20.25 (5.04)	5.00 (1.25)	3.80 (0.95)	1.90 (0.47)
10000 (283)	---	---	---	30.80 (7.67)	25.00 (6.23)	6.22 (1.55)	4.60 (1.15)	2.10 (0.52)
12000 (340)	---	---	---	44.20 (11.01)	36.00 (8.97)	9.00 (2.24)	6.80 (1.69)	2.40 (0.60)
14000 (369)	---	---	---	---	---	12.20 (3.04)	9.30 (2.32)	2.80 (0.70)
16000 (453)	---	---	---	---	---	16.00 (4.00)	12.10 (3.01)	3.40 (0.85)
18000 (510)	---	---	---	---	---	20.20 (5.03)	15.30 (3.81)	4.40 (1.10)
20000 (566)	---	---	---	---	---	25.00 (6.23)	18.90 (4.71)	5.40 (1.35)
25000 (708)	---	---	---	---	---	40.60 (10.11)	30.70 (7.65)	8.90 (2.22)
30000 (849)	---	---	---	---	---	---	42.50 (10.59)	12.40 (3.09)
35000 (991)	---	---	---	---	---	---	---	17.05 (4.25)
40000 (1133)	---	---	---	---	---	---	---	21.70 (5.41)
45000 (1274)	---	---	---	---	---	---	---	27.40 (6.83)
50000 (1416)	---	---	---	---	---	---	---	33.80 (8.42)
55000 (1557)	---	---	---	---	---	---	---	41.00 (10.21)

NOTE: Do not exceed 36" pressure drop when determining acceptable capacities at which these controls may be used. Under some conditions, these limits may be surpassed, but only after consultation with Maxitrol. See pages 58-59 for Regulator Sizing Requirements and Examples.

Spring Selection

Model	Available Springs	
220D	1 psi to 3 psi (6.9 kPa to 20.7 kPa) Red	2 psi to 5 psi (13.8 kPa to 34.5 kPa) Yellow
220E	1 psi to 3 psi (6.9 kPa to 20.7 kPa) Red	2 psi to 5 psi (13.8 kPa to 34.5 kPa) Yellow
220G	1 psi to 3 psi (6.9 kPa to 20.7 kPa) Red	2 psi to 5 psi (13.8 kPa to 34.5 kPa) Yellow
220J	1 psi to 3 psi (6.9 kPa to 20.7 kPa) Red	2 psi to 5 psi (13.8 kPa to 34.5 kPa) Yellow

NOTE: See pages 56-57 for complete Spring Selection Chart.

220 SERIES

Pilot Loaded Design

Dimensions

Model	Pipe Size	Vent Connection	Swing Radius	Dimensions			
				A	B	C	D
220D	1", 1 1/4", 1 1/2"	12A06 vent limiting device installed.	8.1" (206 mm)	9.5" (241 mm)	7" (178 mm)	5.5" (140 mm)	8.3" (210 mm)
220E	1 1/2", 2"	12A06 vent limiting device installed.	8.6" (217 mm)	11.2" (285 mm)	9.1" (232 mm)	7.6" (194 mm)	10" (256 mm)
220G	2 1/2", 3"	12A06 vent limiting device installed.	10.4" (264 mm)	14.2" (362 mm)	13.5" (343 mm)	10.4" (264 mm)	15.8" (400 mm)
220J	4"	12A06 vent limiting device installed.	—	20.5" (520 mm)	18" (457 mm)	13.9" (352 mm)	20" (508 mm)

NOTE: Dimensions are maximums and to be used only as an aid in designing clearance for the valve. Actual production dimensions may vary somewhat from those shown.

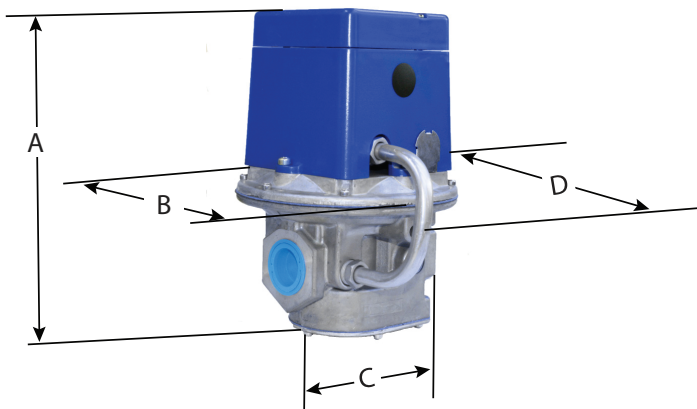

220D, 220E, 220G

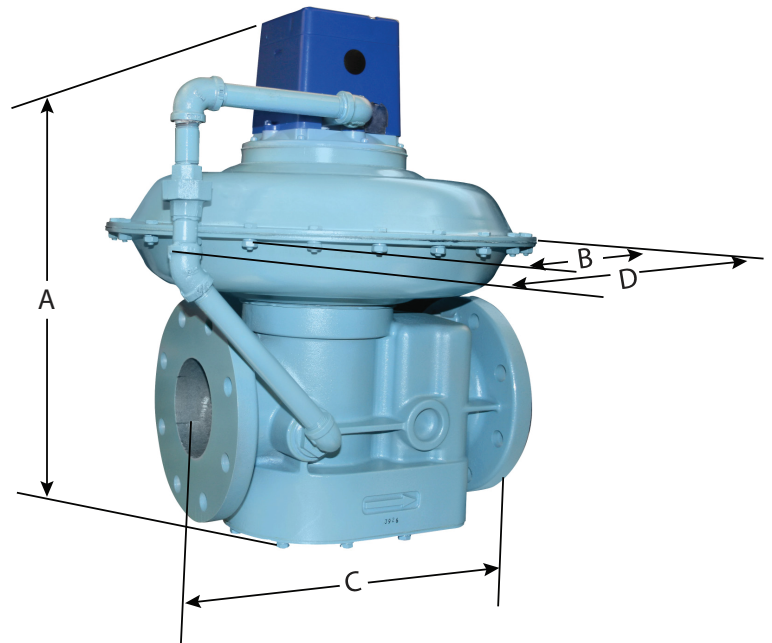

220J

Pilot Loaded Design

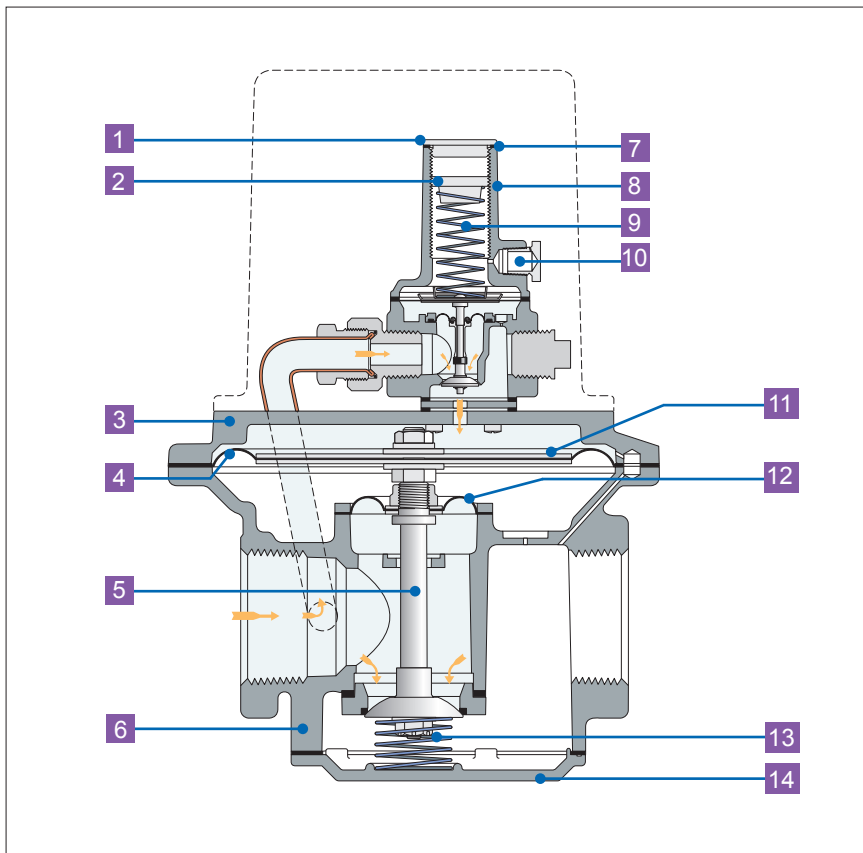

- 1 Seal Cap
- 2 Adjusting Screw
- 3 Top Housing
- 4 Regulating Diaphragm
- 5 Stem & Valve
- 6 Bottom Housing
- 7 Seal Cap Gasket
- 8 Stack
- 9 Spring
- 10 Vent Connection
- 11 Diaphragm Plates
- 12 Balancing Diaphragm
- 13 Counter Spring
- 14 Bottom Plate

NOTE: Diagrams are graphical representations only and may differ from actual product.