

V5197A Firing Rate Gas Valve

PRODUCT DATA

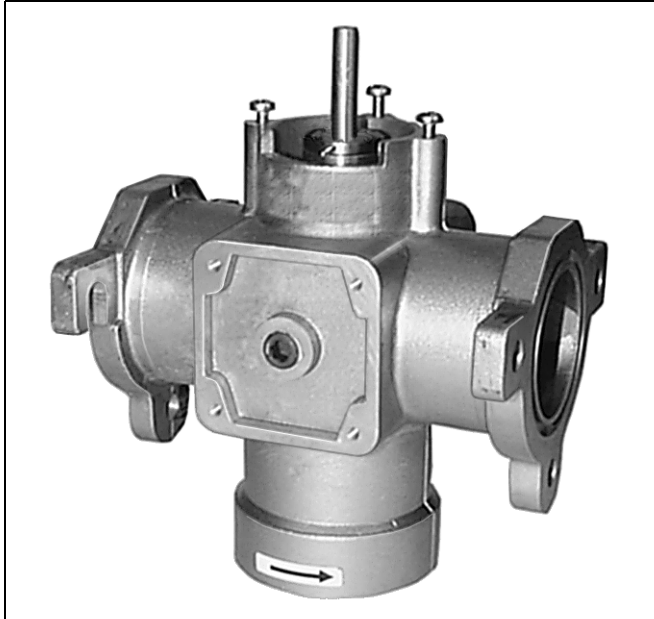

FEATURES

- Used with air, natural, manufactured or liquefied petroleum (LP) gases.
- For modulating applications that do not require final shutoff service of firing rate valve.
- Two valve body types (small and large) applicable to seven pipe sizes:
- Small body type for 3/4 in. (19 mm), 1 in. (25 mm), 1-1/4 in. (32 mm), 1-1/2 in. (38 mm) and 2 in. (51 mm) pipes, NPT or ISO 7 threads.
- Large body type for 2 in. (51 mm), 2-1/2 in. (64 mm) and 3 in. (76 mm) pipes, NPT or ISO 7 threads.
- Two downstream 1/4 in. NPT threaded pressure taps available.
- Accepts C6097 Pressure Switch mounted directly to flange (downstream pressure tap only).
- Unpainted cast aluminum body.
- Suitable for electric or pneumatic operators with the appropriate linkage.
- May be used with manufacturers own linkage and drive motor.
- Flow adjustment screw on bottom of valve controls maximum flow.
- Visual position indicator.

APPLICATION

The V5197A is a firing rate valve used to provide variable flow control of air, natural gas, liquefied petroleum (LP), and manufactured gases. The V5197A is actuated by a firing rate motor that can be mounted directly on the valve. The V5197A is not applicable as a safety shutoff valve.

The V5197A is specially designed to provide fine control of gas flow in applications where a high turn down ratio is required.

The maximum flow adjustment screw on the bottom of the valve allows adjusting the maximum flow of gas through the V5197 while maintaining the linear modulating characteristics and stroke.

The V5197A is part of the Honeywell Integrated Valve Train System that allows gas train components to be directly bolted together.

Contents

Application	1
Features	1
Specifications	2
Ordering Information	2
Installation	5
Checkout and Operation	8
Service Information	8



SPECIFICATIONS

IMPORTANT

The specifications in this publication do not include normal manufacturing tolerances; therefore, an individual unit may not exactly match the specifications listed. Also, this product is tested and calibrated under closely controlled conditions, and some minor differences in performance can be expected if those conditions are changed.

Models:

V5197A1003: Small body.

V5197A1011: Large body.

Type of Gas: Air, natural, manufactured, mixed or liquefied petroleum (LP) gases only.

Pipe Size of the gas train: 3/4 in. (19 mm), 1 in. (25 mm), 1-1/4 in. (32 mm), 1-1/2 in. (38 mm), 2 in. (51 mm), 2-1/2 in. (64 mm), 3 in. (76 mm).

Pressure Rating: Maximum operating pressure of 15 psi (1 Bar).

Maximum Valve Capacities: SCFH gas: 0.64 sp. gr. at 1 in. wc pressure drop across valve (flow limit adjustment set at 100% open). See Table 1.

**Table 1. Maximum Flow Capacity
(natural gas at 0.64 sp.gr.) at 1 in. w.c. (2.5 mBar)
Pressure Drop Across Valve.^a**

Pipe Size in in. (mm)	Flow Capacity	
	SCFH	SCMH
3/4 (19)	2450	69
1 (25)	3080	87
1-1/4 (32)	4430	125
1-1/2 (38)	5010	142
2 (51)—small body	5480	155
2 (51)—large body	12,600	356
2-1/2 (64)	14,800	419
3 (76)	16,900	478

^a Standard cubic feet per hour (SCFH) and standard cubic meters per hour (SCMH) listed. For other gases, multiply the listed capacity by the square root of (0.64 divided by the specific gravity of the other gas).

Flow curves: See Fig. 1 through 8.

ORDERING INFORMATION

When purchasing replacement and modernization products from your TRADELINE® wholesaler or distributor, refer to the TRADELINE® Catalog or price sheets for complete ordering number.

If you have additional questions, need further information, or would like to comment on our products or services, please write or phone:

1. Your local Honeywell Automation and Control Products Sales Office (check white pages of your phone directory).
2. Honeywell Customer Care
1885 Douglas Drive North
Minneapolis, Minnesota 55422-4386

In Canada—Honeywell Limited/Honeywell Limitée, 35 Dynamic Drive, Scarborough, Ontario M1V 4Z9.

International Sales and Service Offices in all principal cities of the world. Manufacturing in Australia, Canada, Finland, France, Germany, Japan, Mexico, Netherlands, Spain, Taiwan, United Kingdom, U.S.A.

NOTE: The percentage settings listed on the figures refer to the setting of the flow adjustment screw on the bottom of the V5197. Pressure drops are shown as solid, broken or dotted lines on the figures.

Bolt/Nut Fasteners (Provided with the valve):

Small body: 3/8-16 by 1-3/8, Grade 5 bolt. Metric equivalent M8x1.25x35mm, class 9.8. Tighten to 13 ft-lb (18 N•m).

Large body: 1/2-13 by 2.00, Grade 5 bolt. Metric equivalent M12x1.75x50mm, class 9.8. Tighten to 25 ft-lb (34 N•m).

Tapping and plug: Two downstream 1/4 in. NPT taps.
Plugs : 1/4 in. hex socket.

Ambient Operating Temperature Rating: -40°F to +150°F (-40°C to +66°C).



Material: Cast aluminum body, brass and stainless steel internal parts, NBR seals.

Mounting: Directly bolted to Integrated Valve Train (IVT) components or IVT adapters.

Mechanical Strength: Group 2.

Maximum flow adjustment (Fig 9):

Located on the bottom of the valve with a 1/4 in. (6 mm) hex key:

To decrease the maximum flow, turn clockwise ;
to increase the maximum flow, turn counterclockwise .

Mounting position: Any position.

Dimensions: See Fig. 10 and 11.

Weight:

Small Body—5-1/4 lb (2.4 kg).

Large Body— 11-5/8 lb (5.3 kg).

Accessory: 201391 Shaft Adapter for 3/8 in. (10 mm) round or square shaft (provided with both small body and large body valves).

Approvals:

Underwriters Laboratories, Inc. (UL).

CSA.

EN161 Approval requires the use of an EN161-approved actuator.

CE.

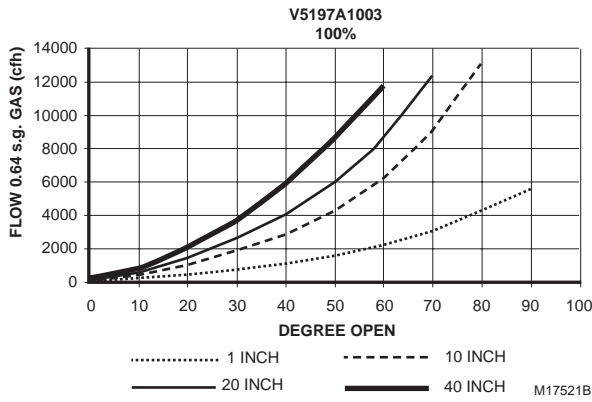

Fig. 1. V5197A (small body) flow curves at stated pressure drops with flow adjustment set at 100%.

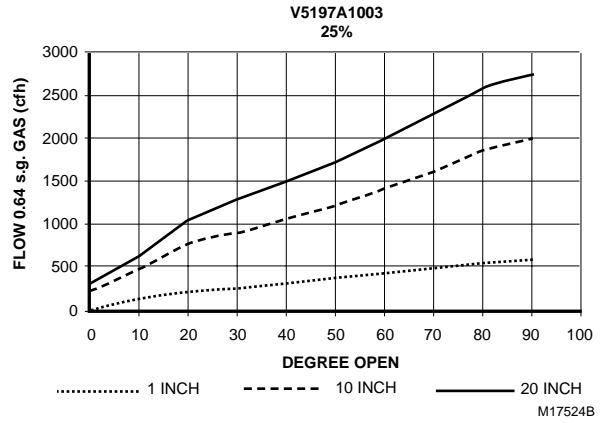

Fig. 4. V5197A (small body) flow curves at stated pressure drops with flow adjustment set at 25%.

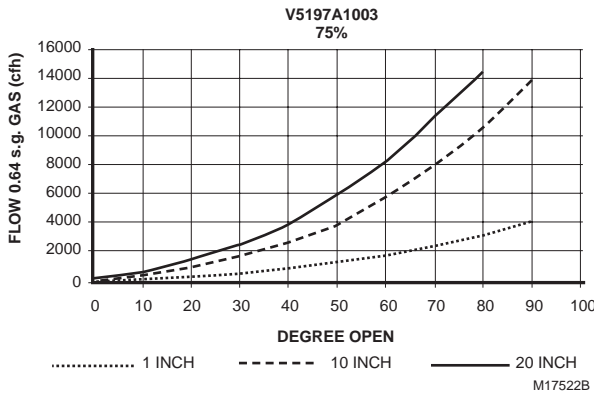

Fig. 2. V5197A (small body) flow curves at stated pressure drops with flow adjustment set at 75%.

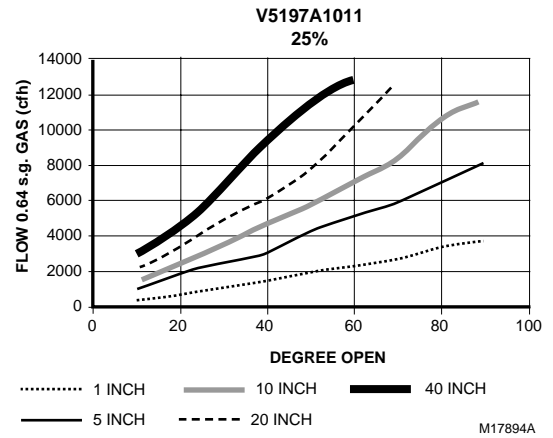

Fig. 5. V5197A (large body) flow curves at stated pressure drops with flow adjustment set at 25%.

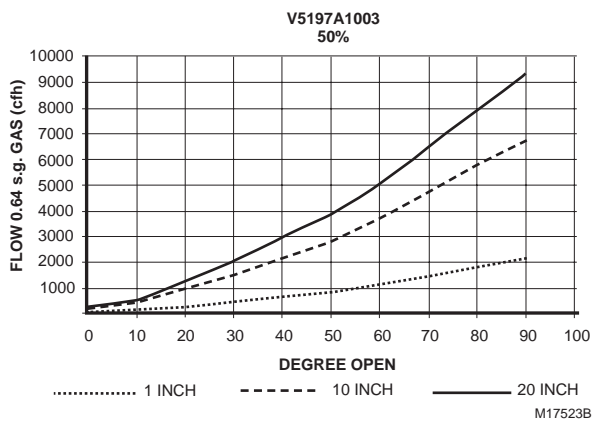

Fig. 3. V5197A (small body) flow curves at stated pressure drops with flow adjustment set at 50%.

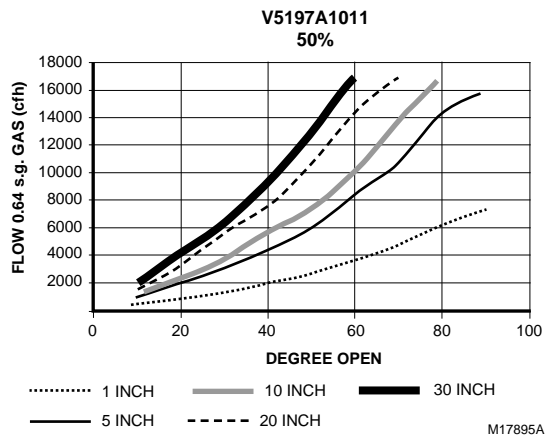

Fig. 6. V5197A (large body) flow curves at stated pressure drops with flow adjustment set at 50%.

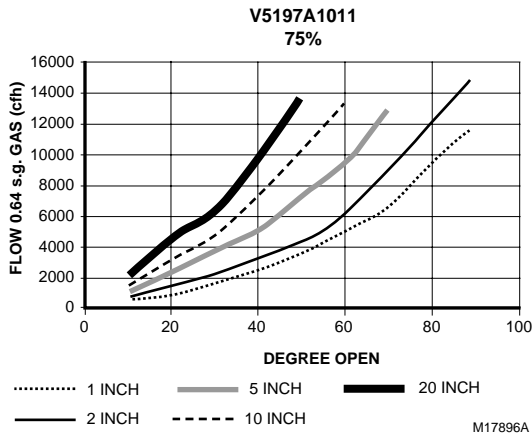

Fig. 7. V5197A (large body) flow curves at stated pressure drops with flow adjustment set at 75%.

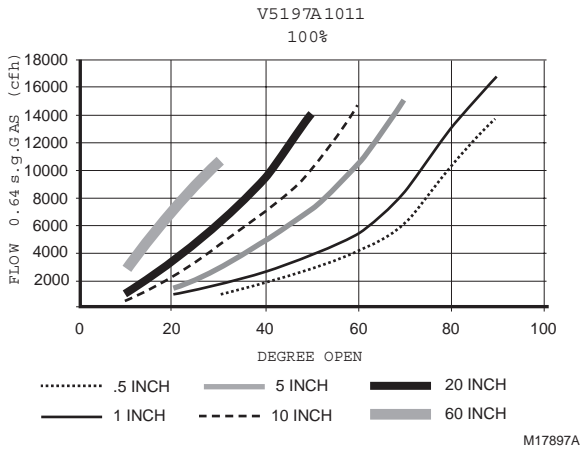

Fig. 8. V5197A (large body) flow curves at stated pressure drops with flow adjustment set at 100%.

Accessories:

201391 3/8 in. Shaft Adapter for mounting ML7999A/B to V5197.

Pipe Adapters, NPT:

- 32000109-001 3/4 in. (19 mm).
- 32000109-002 1 in. (25 mm).
- 32000109-003 1-1/4 in. (32 mm).
- 32000109-004 1-1/2 in. (38 mm).

- 32000109-005 2 in. (51 mm)—small body valve only.
- 32001605-001 2 in. (51 mm)—large body valve only.
- 32001605-002 2-1/2 in. (64 mm).
- 32001605-003 3 in. (76 mm).

Pipe Adapters, BSP:

- 32000109-006 3/4 in. (19 mm).
- 32000109-007 1 in. (25 mm).
- 32000109-008 1-1/4 in. (32 mm).
- 32000109-009 1-1/2 in. (38 mm).
- 32000109-010 2 in. (51 mm)—small body valve only.
- 32001605-004 2 in. (51 mm)—large body valve only.
- 32001605-005 2-1/2 in. (64 mm).
- 32001605-006 3 in. (76 mm).

4074EYE Bag Assembly (bolts, nuts and washers for large body valve), supplied.

4074EYF Bag assembly (bolts, nuts and washers for small body valve), supplied.

4074EYK Bag Assembly (O-rings and tube of lubricant for small body valve), supplied.

4074EYL Bag Assembly (O-rings and tube of lubricant for large body valve), supplied.

The following non-part-numbered items are provided with the valve:

- ML7999 Actuator Mounting Bracket
- Mounting Bracket Screws
- Valve Drive Stem

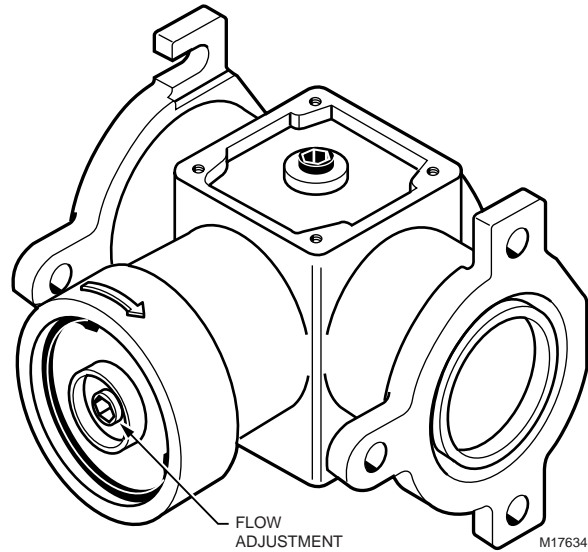

Fig. 9. V5197 Flow Adjustment.

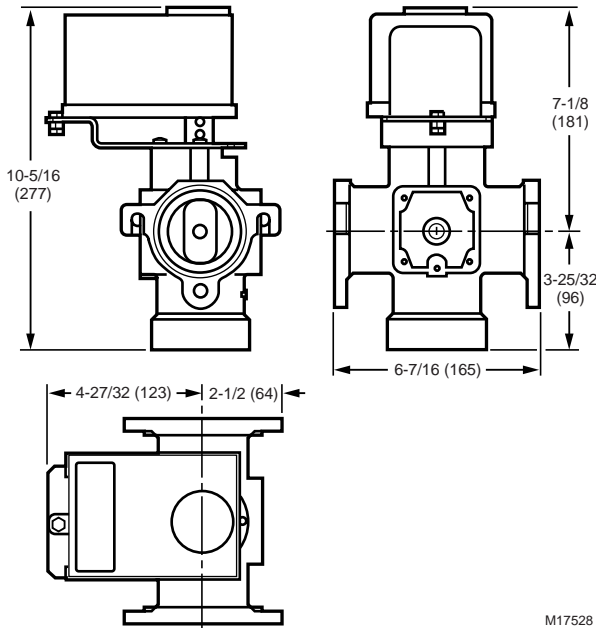

Fig. 10. V5197A Firing Rate Gas Valve (small body), with mounting bracket (included) and ML7999 Actuator (not supplied), dimensions in in. (mm).

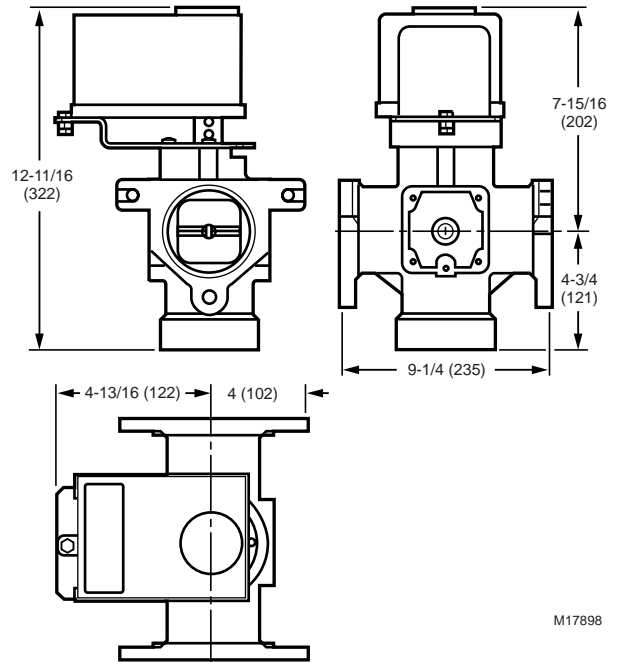

Fig. 11. V5197A Firing Rate Gas Valve (large body), with mounting bracket (included) and ML7999 Actuator (not supplied), dimensions in in. (mm).

INSTALLATION

When Installing this product...

1. Read these instructions carefully. Be sure to follow Warning information carefully.
2. Check the ratings given in the instructions and on the product to make sure the product is suitable for your application.
3. Installer must be a trained, experienced flame safeguard control technician.
4. After installation is complete, check out product operation as provided in these instructions.

⚠ WARNING

Explosion Hazard and Electrical Shock Hazard. Can cause explosion, serious injury or death.

1. Turn off gas supply before starting installation.
2. Disconnect power supply for valve actuator (if applicable) before beginning installation. More than one disconnection can be involved.

Installation

IMPORTANT

Install the valve so the arrow on the valve body points in the gas flow direction.

Installing the Valve Drive Stem in the V5197

1. Place the short end of the Valve Drive Stem in the top of the V5197 Valve drive so that the square portion of the drive stem is fully engaged in the square hole in the valve drive assembly. See Fig. 12.

NOTE: The short end of the Valve Drive Stem is 1 in. (25 mm) in length (measured from the square portion of the stem); the long end of the Valve Drive Stem is 1-1/8 in. (35 mm) long.

2. Tighten the valve position indicator setscrew (located in the valve drive assembly) to a torque setting of 5 inch-pounds (80 inch-ounces/6 kg-cm).

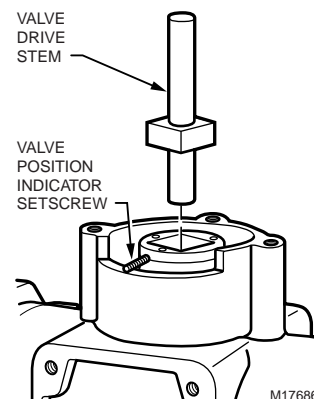

Fig. 12. Inserting the Valve Drive Stem in the V5197 Valve.

Installing the V5197 in the IVT

Refer to the Integrated Valve Train Installation instructions (form 66-1099) for complete instructions on mounting a V5197A in a Honeywell Integrated Valve Train System.

Allow sufficient clearance for assembling the motor and linkage (if applicable), and for general servicing.

IMPORTANT

Install the valve so the arrow on the valve body points in the gas flow direction. Make sure the O-ring seals (provided) are properly positioned and seated at the inlet and outlet flange connections.

1. Install the V5197 Valve so the arrow on the valve body points in the gas flow direction.

NOTE: Normally, the V5197 will be located downstream of the safety shutoff valve(s) in the Integrated Valve Train. Refer to form 66-1099 or the following steps.

2. Using the grease packet provided (or equivalent, general purpose, lithium grease), grease the O-rings provided with the valve. Make sure the grease is applied evenly around the O-ring. See Fig. 13.

3. Connect the V5197 Valve to the safety shutoff valve (SSOV) using three bolts, nuts and lockwashers as shown in Fig. 13.

NOTE: Tightening torque for nuts/bolts:

- Small body flanges: 13 ft-lb (18 N-m).
 - Large body flanges: 25 ft-lb (34 N-m).
4. Connect the pipe adapter to the other end of the V5197 Valve using three bolts, nuts and lockwashers.
 5. Assemble the downstream gas piping:
 - a. Use new, properly reamed, pipe, free from chips.
 - b. Apply moderate amounts of good quality pipe dope, resistant to the action of liquid propane (LP) gas, on the pipe threads. See Fig. 14.
 - c. Do not thread pipe too far into pipe adapter. The pipe should end flush with the O-ring sealing surface of the pipe adapters. Valve distortion or malfunctions can result from excess pipe in the valves.
 6. Mount the ML7999 Actuator on the V5197 Valve and secure the actuator to the mounting bracket.
 7. Wire the ML7999 Actuator according to instructions in form no. 65-0239.
 8. Restore power to the system.

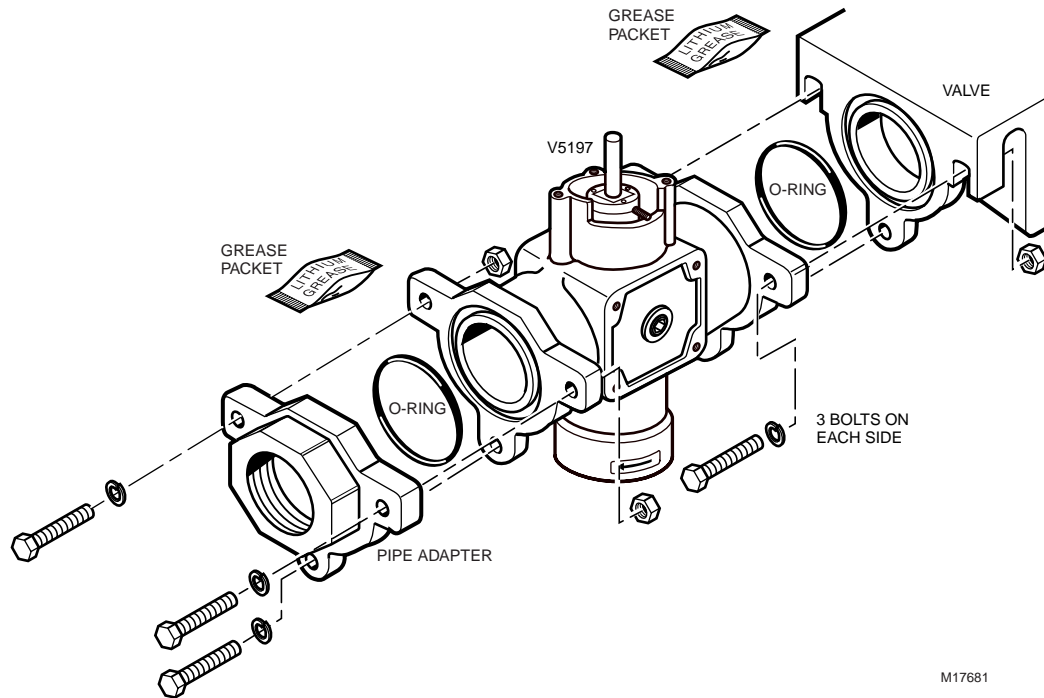

Fig. 13. Mounting the V5197 Valve in the IVT.

Mounting the ML7999 Mounting Bracket

The ML7999 Actuator and mounting bracket can be installed in one of four positions, depending on accessibility of the valve and actuator. See Fig. 15.

1. Choose the actuator and bracket position best suited for your location and place the mounting bracket over the drive shaft of the V5197 valve. See Fig. 16.
2. Manually open the V5197 valve for proper alignment of the ML7999 Actuator.
3. Secure the mounting bracket with the three screws provided.

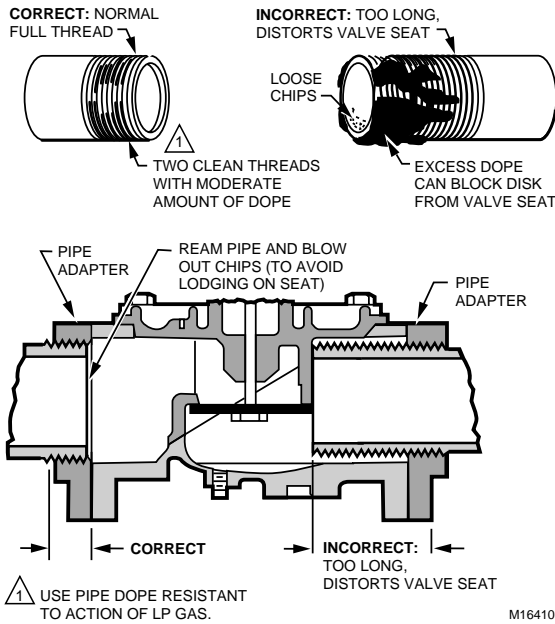

Fig. 14. Preparing pipes.

Mounting the ML7999 Actuator

1. Insert the shaft adapter and place the actuator over the shaft. Position and seat the actuator.

NOTE: Use the 201391 shaft adapter (included with the valve) to mount the ML7999 Actuator to the V5197 Valve drive stem. Place the adapter as shown in Fig. 16 so that the valve drive shaft is between the adapter and the four setscrews.

2. Secure the actuator to the mounting bracket using a bolt, nut and locking washer. See Fig. 17.

CAUTION

Equipment Damage Hazard.

Improper alignment can damage the actuator.

Align the ML7999 Actuator bottom panel parallel with the ML7999 mounting bracket (Fig. 18). Failure to do so will cause undue stress on the actuator motor and shorten its operating life.

3. Partially tighten the four hub setscrews to ensure that the actuator seats firmly against the mounting bracket with the shaft centered in the actuator hub. See note 1 in Fig. 18.
4. Tighten the anti-rotation bolt to the torque recommendation for the selected bolt/nut.
5. Tighten the hub setscrews against the shaft to a torque of 60 in-lb (69 kg-cm). See Fig. 17.

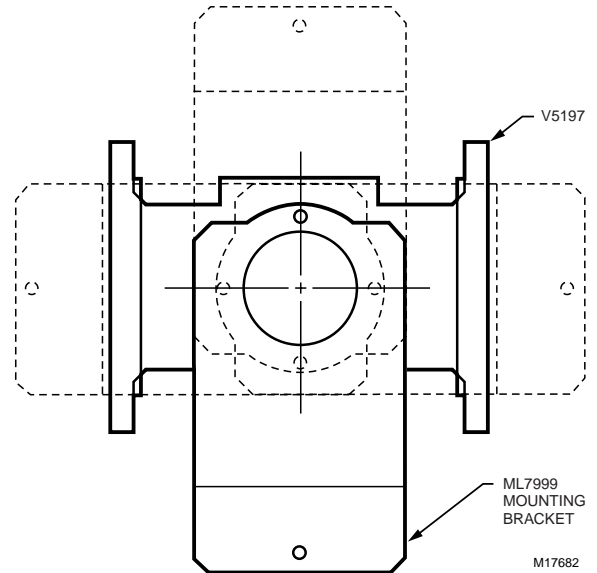

Fig. 15. Possible mounting positions of the ML7999 Actuator and mounting bracket.

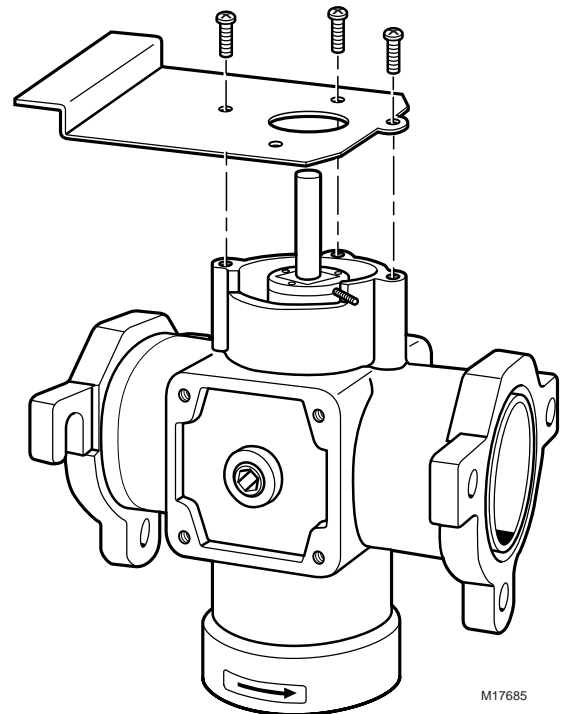

Fig. 16. Attaching the ML7999 Actuator mounting bracket to the V5197 Valve (valve in the open position).

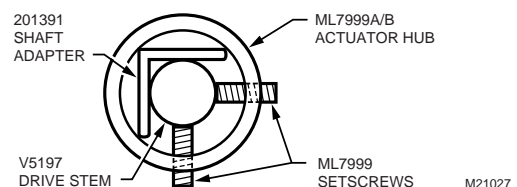

Fig. 17. Proper positioning of 201391 shaft adapter and V5197 drive shaft.

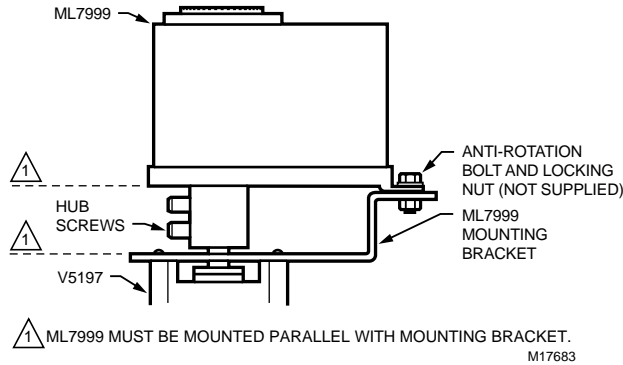

Fig. 18. Mounting the ML7999 Actuator on the V5197 Valve.

CHECKOUT AND OPERATION

Checkout

⚠ WARNING

Explosion Hazard and Electrical Shock Hazard. Can cause explosion, serious injury or death.

1. Do not allow fuel to accumulate in the combustion chamber for longer than a few seconds without igniting. An explosive mixture can result.
2. Do not put the system into service until you have satisfactorily completed the following Valve Leak Test, all applicable tests described in the Checkout section of the instructions for the flame safeguard control, and any other tests required by the burner manufacturer.
3. All tests must be performed by a trained, experienced flame safeguard control technician.
4. Close all manual fuel shutoff valves as soon as trouble occurs.

After the installation is completed, cycle the valve several times with the manual fuel shutoff cock closed. Make sure the valve and actuator function properly. Also perform the Valve Leak Test before putting the valve into service.

Valve Leak Test



This is a test for checking the leakage tightness of the firing rate gas valve only. It should be performed only by trained, experienced flame safeguard control technicians during the initial startup of the burner system, or whenever the valve is

replaced (see Service Information section). It is recommended that this test also be included in the scheduled inspection and maintenance procedures.

NOTE: Additional leakage and closure tests may be required for other gas train components (for example, safety shutoff valves [SSOV]).

1. Close the downstream manual gas valve(s).
2. Energize the valve train to apply gas pressure.
3. Test with rich soap and water solution to make sure there is no leak at any pipe adapter/valve mating surfaces.
4. Restore the system to normal operation.

Operation

A V5197A Firing Rate Gas Valve is operated by an actuator. The valve opens counterclockwise  and closes clockwise . When closed, the valve does not totally seal off the gas flow and has no safety shutoff function. For further information, refer to the actuator instructions.

Make sure that the actuator does not force the V5197 Valve beyond the limits of the valve stroke (90 degrees). This can damage or destroy the valve position indicator setscrew.

SERVICE INFORMATION

⚠ WARNING

Explosion Hazard and Electrical Shock Hazard. Can cause explosion, serious injury or death.

1. Turn off the gas supply and disconnect all electrical power to the valve actuator before servicing.
2. Properly position and seat the seals in ends of the valve body to prevent a hazardous gas leak. Read these instructions and form 66-1099 carefully for servicing information.

IMPORTANT

Only trained, experienced flame safeguard control technicians should attempt to service or repair flame safeguard controls and burner assemblies.

Scheduled Inspection and Maintenance

Set up and follow a schedule for periodic inspection and maintenance for the burner, all other controls and the valves. It is recommended that the valve leak test in the Operation and Checkout section be included in this schedule. Refer to the instructions for the primary safety control and safety shutoff valve(s) for more information.

Honeywell

Automation and Control Solutions

Honeywell International Inc.	Honeywell Limited-Honeywell Limitée
1985 Douglas Drive North	35 Dynamic Drive
Golden Valley, MN 55422	Scarborough, Ontario
	M1V 4Z9

