

## V51E Butterfly Valve

*The V51E Butterfly Valve is a firing rate valve used to provide variable flow control of natural, liquefied petroleum (LP), and manufactured gases. It is also applicable to controlling airflow. The V51E Valve is actuated by a firing rate motor mounted directly on the valve. The V51E is not applicable as a safety shutoff valve.*

*The V51E Valve provides high capacity with a relatively constant relationship between flow rate and opening plate angle. The V51E firing rate motor assembly is especially adaptable to commercial and industrial installations that require close control of large gas capacities.*



- 
- Variety of valve sizes, firing rate motors and linkages. For most modulating applications that do not require final shutoff service of firing rate valve.
  - Rugged cast aluminum body provides durability and maintenance-free operation.
  - Compatible with Modutrol Motor and Q100A or B Linkage, Actionator Motor and Q100C Linkage, and Type 03 Air-O-Motor Pneumatic Actuator and Q524A Linkage.
  - The valve mechanism is equipped with strain release springs.
  - Suitable for electric or pneumatic operators with the appropriate linkage.
  - May be used with manufacturers own linkage and drive motor.

### **CONTENTS**

<i>Specifications</i> .....	2
<i>Ordering Information</i> .....	2
<i>Installation</i> .....	5
<i>Adjustments and Checkout</i> .....	8
<i>Maintenance</i> .....	8

# Specifications

**IMPORTANT:** *The specifications in this publication do not include normal manufacturing tolerances. Therefore, units may not exactly match the listed specifications. Also, products are tested and calibrated under closely controlled conditions, and some minor differences in performance can be expected if those conditions are changed.*

MODEL: V51E Butterfly Valve.

TYPES OF GASES: Natural, liquefied petroleum (LP), manufactured, and air.

FLOW CAPACITIES: See Fig. 1.

SIZES: 1-1/2, 2, 2-1/2, 3, and 4 inches.

PATTERN: Straight-through.

BODY MATERIAL: Aluminum.

MAXIMUM INLET PRESSURE: 5 psig. See Fig. 3.

AMBIENT TEMPERATURE RANGE: 32° F to 140° F  
[0° C to 60° C].

MAXIMUM FLUID TEMPERATURE: 140° F.

DIMENSIONS: See Fig. 2.

ACCESSORIES:

- 16350 Actuating Lever Pin.
- 16351 Operating Arm Relief Pin.
- 22355 Stop Screw Locking Nuts (two required).
- 49084 Adjusting Arm.
- 49085B Strain Release Assembly for Q100A.

- 49087 Spring.
- 49090 Yoke Pin for mounting actuating arm to linkage.
- 80897BC Stop Screws for stop bracket (two required).
- 104266 Q100 Actuator Arm.
- 127411 Bracket for 1-1/2 in. V51E.
- 127413 Bracket for 2 in. V51E.

APPROVALS:

Underwriters Laboratories Inc.: File No. MH5968, Vol. I,  
Section 1, Guide No. MHKZ.

Fig. 1—V51E Valves Flow Capacities.

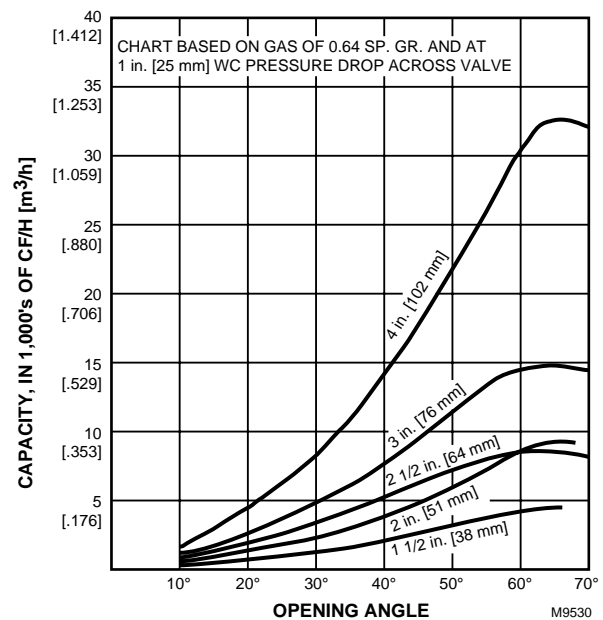

# Ordering Information

When purchasing replacement and modernization products from your TRADELINE® wholesaler or your distributor, refer to the TRADELINE® catalog or price sheets for complete ordering number, or specify:

1. Valve model.
2. Valve size (1-1/2, 2, 2-1/2, 3, 4 inches)
3. Accessories.
4. Order motor and linkage separately. Refer to applicable Specifications.

If you have additional questions, need further information, or would like to comment on our products or services, please write or phone:

1. Your local Honeywell Home and Building Control Sales Office (check white pages of phone directory).
2. Home and Building Control Customer Logistics  
Honeywell Inc.,  
1885 Douglas Drive North  
Minneapolis, Minnesota 55422 (612) 951-1000

In Canada—Honeywell Limited/ Honeywell Limitée, 740 Ellesmere Road, Scarborough, Ontario M1P 2V9. International Sales and Service Offices in all principal cities of the world. Manufacturing in Australia, Canada, Finland, France, Germany, Japan, Mexico, Netherlands, Spain, Taiwan, United Kingdom, U.S.A.

Fig. 2—V51E Assembly dimensions in in. [mm].

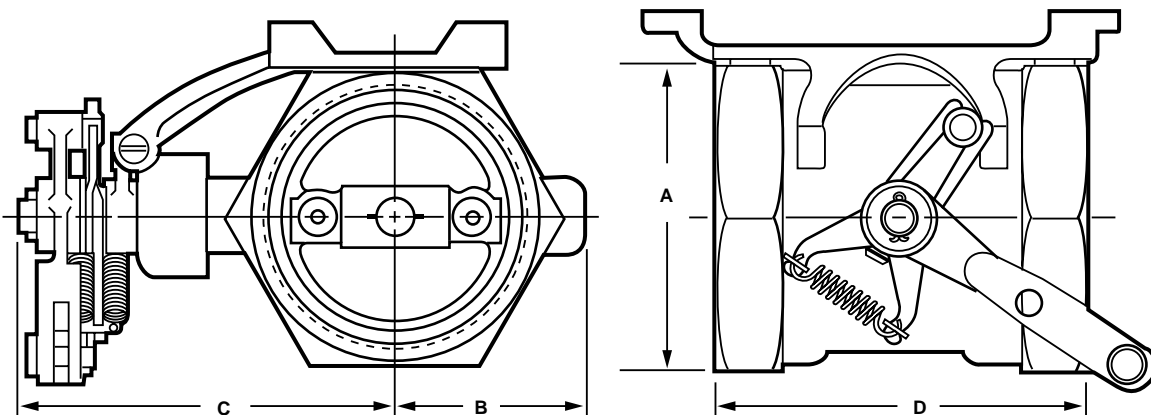

V51E DIMENSIONS

VALVE SIZE (in.)	A <sup>1</sup>		B <sup>1</sup>		C <sup>2</sup>		D <sup>1</sup>	
	in.	mm	in.	mm	in.	mm	in.	mm
1 1/2	2 21/32	67.5	1 9/16	39.7	4 1/4	108.0	3 1/32	77.0
2	3 5/32	80.2	1 13/16	46.0	4 1/4	108.0	3 17/32	89.7
2 1/2	3 27/32	97.6	2 5/16	58.7	4 13/16	122.2	4 23/32	119.9
3	4 1/32	102.4	2 25/64	60.7	5	127.0	4 23/32	119.9
4	5 21/64	135.3	3 5/32	80.2	5 3/8	136.5	5 17/64	133.8

<sup>1</sup> MAXIMUM DIMENSIONS.  
<sup>2</sup> NOMINAL DIMENSIONS.

M9532

**Fig. 3—Pressure drop versus capacity. Maximum opening angles shown are used as trial settings when adjusting valves for high fire.**

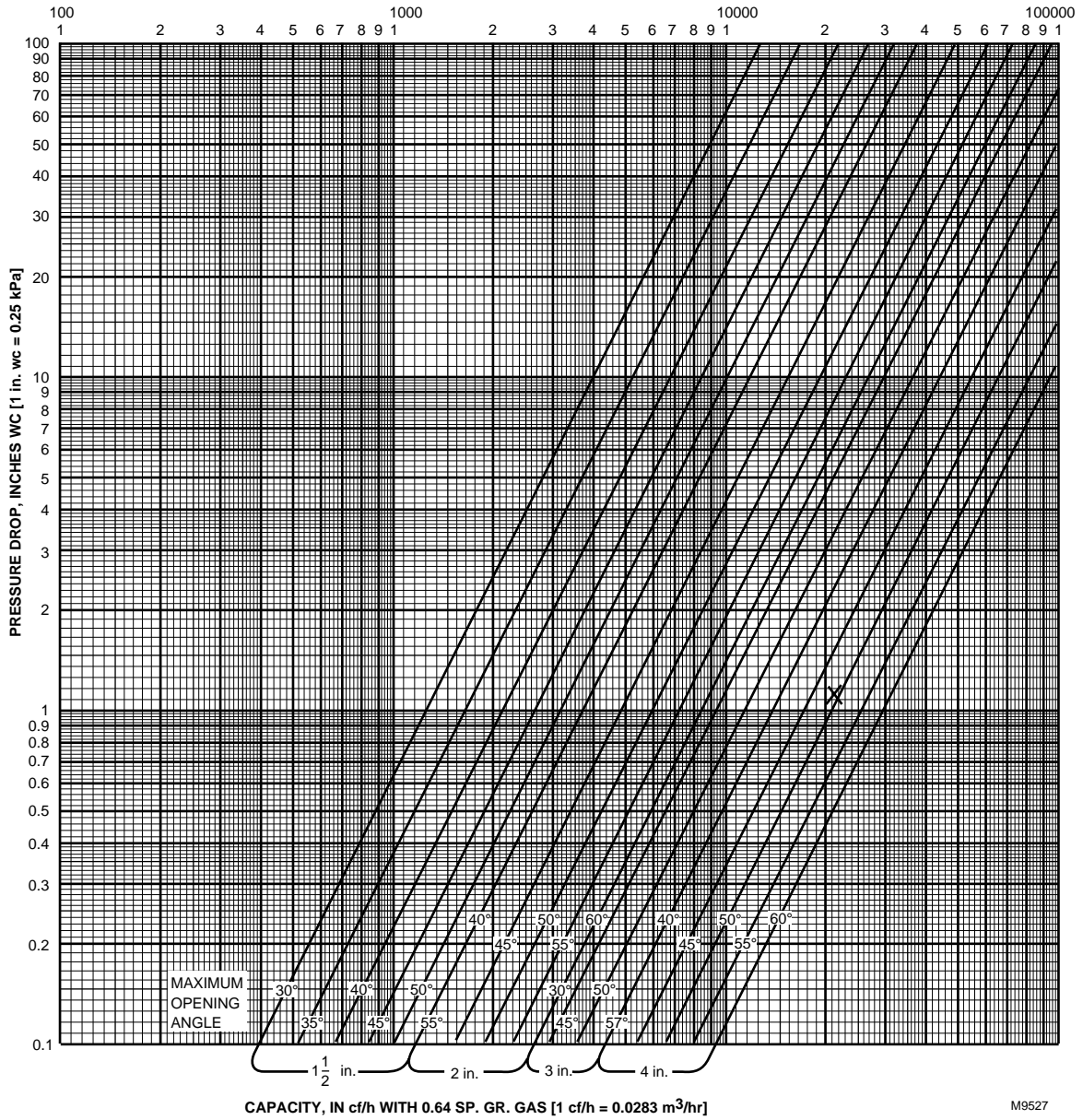

# Installation

## WHEN INSTALLING THIS PRODUCT...

1. Read these instructions carefully. Failure to follow them could damage the product or cause a hazardous condition.
2. Check the ratings given in the instructions and on the product to make sure the product is suitable for your application.
3. Installer must be a trained, experienced, flame safeguard control technician.
4. After installation is complete, check out product operation as provided in these instructions.



## CAUTION

1. Turn off gas supply before starting installation.
2. Disconnect power supply before beginning installation to prevent electrical shock and equipment damage.

## MOUNTING

Electric motorized valves of this type should not be installed in poorly ventilated pits or confined spaces for control of combustible gas flow. The valve body may be installed in any position provided the motor shaft is horizontal. Allow sufficient clearance for assembling the motor and linkage, and for general servicing. See Fig. 2 for installation dimensions.

## PIPING

The valve body may be piped either by screwing directly to the pipe or by using close nipples and companion flanges. The pipes must be in exact alignment to avoid distorting the valve body. Ream and clean pipes carefully, and apply pipe dope to the male threads only. Leave the first two threads free of dope.

## INSTALLING ELECTRIC MOTOR AND Q100A LINKAGE ON V51E (FIG. 4)

Any special parts, nuts, or screws needed are furnished in bag assemblies. Install the motor and linkages as follows:

1. Mount plate on stop bracket with three No. 10 screws and lock washers.
2. Mount motor on plate with four 1/4 in. screws, lock washers, and nuts.
3. Remove motor crank arm assembly from motor and discard it.
4. Install the special crankarm in position shown. With crankarm tight against shoulder of shaft, tighten clamp screw securely.
5. One end of the link measures 1-1/4 in. [31.8 mm] from end to bend. Slip this end over the drive pin. Place washer on drive pin. Insert cotter pin in the drive pin and spread cotter pin ends.
6. Slip the other end of the link into the forked end of the actuating arm and insert the linkage pin moving the arm as necessary. Insert cotter pin into the linkage pin and spread cotter pin ends.

Fig. 4—Typical combination of V51E, Modutrol Motor, and Q100A Linkage Assembly.

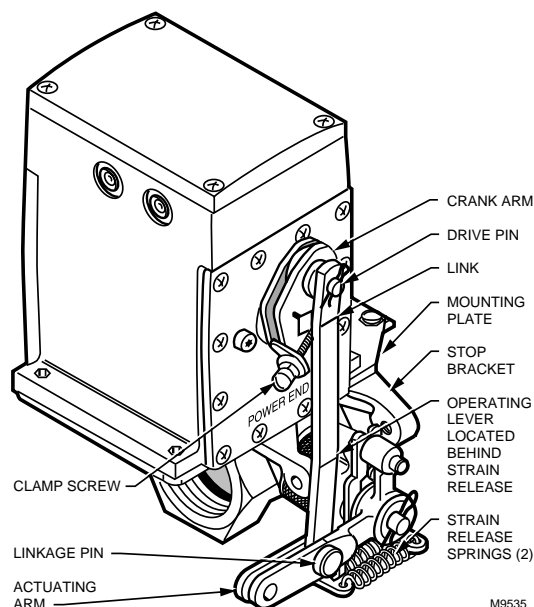
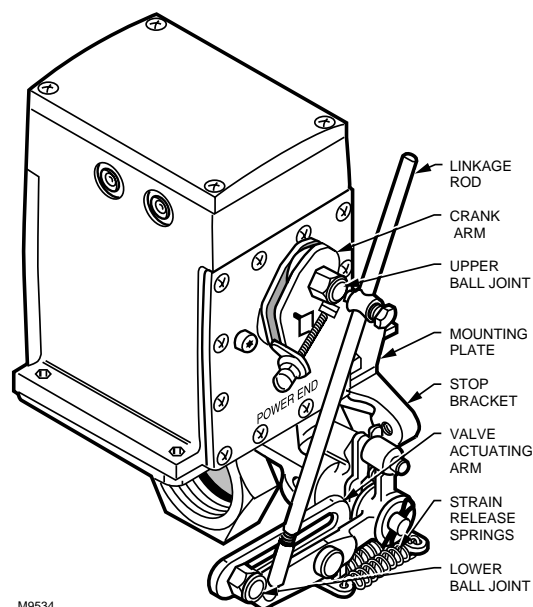

Fig. 5—Typical combination of V51E, Modutrol Motor, and Q100B Linkage Assembly.



## INSTALLING MODUTROL MOTOR AND Q100B LINKAGE ON V51E (FIG. 5)

Special parts needed for the basic assembly are furnished in bag assemblies. Special linkages for the valve arm to operate dampers, auxiliary valves, or other equipment can be

provided by the burner manufacturer or installer. Install the motor and linkage on the valve as follows:

1. Mount plate on stop bracket with three No. 10 screws and lock washers.
2. Mount motor on plate with 1/4 in. screws, lock washers, and nuts.
3. Make sure the motor is in the *closed* position (the position assumed when red and white terminals on motor are shorted together). Install motor crank arm and tighten clamp screw securely.
4. Install valve actuating arm as shown in Fig. 5, and adjust as desired.

**Fig. 6—Typical combination of V51E, Actionator Motor, and Q100C Linkage Assembly.**

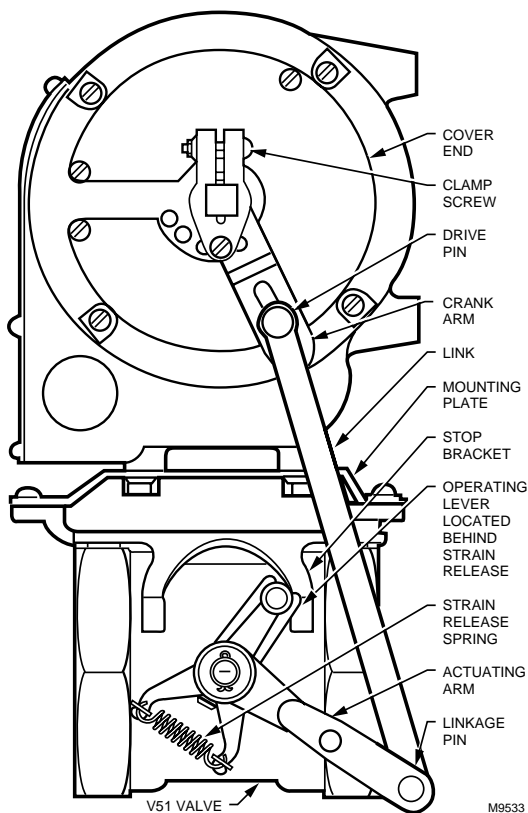

**INSTALLING ACTIONATOR MOTOR AND Q100C LINKAGE ON V51E (FIG. 6)**

1. Mount plate on stop bracket with three No. 10 screws and lock washers.
2. Mount motor on plate with 4-1/4 in. [108.0 mm] hex head screws and lock washers.
3. Install the crank arm in the position shown. With the crank arm tight against the shoulder of the shaft, tighten the clamp screw securely.
4. One end of the link measures 1-3/4 in. [44.5 mm] from the end to the bend. Slip this end of the link into the forked end of the arm and insert the linkage pin, moving the arm as necessary. Insert cotter pin in linkage pin and spread the cotter pin ends.

5. Insert the drive pin into the other end of the link and place a washer on the drive pin. Insert the drive pin into the crank arm and secure the pin with a nut and locking washer.

**WIRING**



**CAUTION**

Disconnect power supply before beginning installation to prevent electrical shock and equipment damage.

Wiring diagrams are packed with the motors. All wiring must comply with applicable codes and ordinances.

**Fig. 7—Recommended *power off* positions of motor lever and valve arm for normally open operation.**

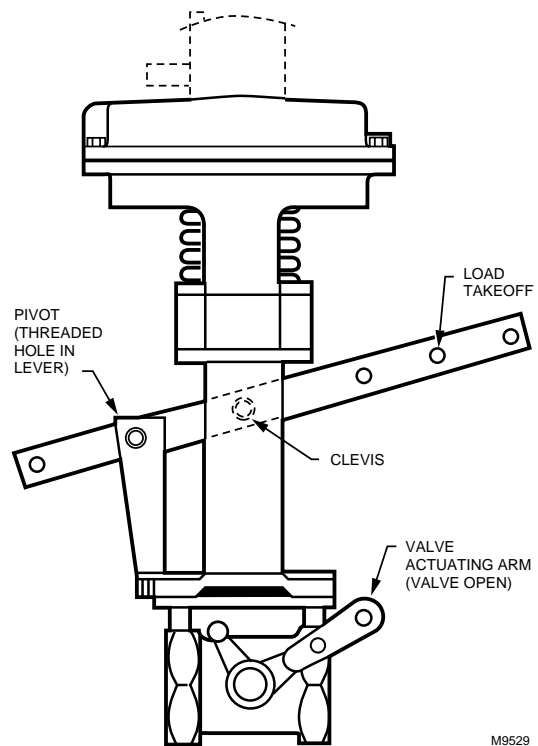

**INSTALLING TYPE 03 AIR-O-MOTOR PNEUMATIC ACTUATOR AND Q524A LINKAGE ON V51E (FIGS. 7, 8, 9)**

The V51E valve is intended to provide normally open, direct operation (valve open when pneumatic pressure off), the actuating arm points to the right as in Fig. 7. For a normally closed system, the arm projects to the left as in Fig. 8. If it is necessary to field-convert the valve, remove only the cotter pin, washer and arm. Reverse the arm and reinstall.

**Fig. 8—Recommended arrangement for normally closed operation.**

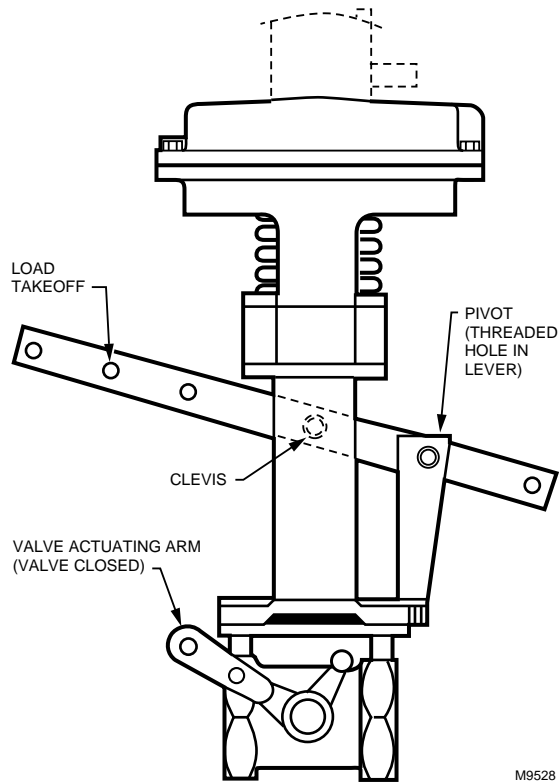

1. Remove the four round-head machine screws and washers holding the stop bracket to the valve hex at each end. Do not remove the stop bracket

2. Position the adapter plate over the stop bracket so that the adapter plate holes match the stop bracket holes.

3. Insert the flat head screws supplied with the linkage assembly through plate, spacers, and stop bracket and into each hex. Tighten securely. The spacers prevent contact of adapter plate and stop bracket. See Fig. 9.

4. Mount the lever arm (13-3/4 in. [349.3 mm]) supplied with the motor so the load takeoff holes will be at the same end of the valve as the valve actuating arm.

NOTE: Both motor lever and valve arm could be installed 180 degrees from the positions shown in Figs. 7 and 8, if more convenient. Use bushing hole at the clevis.

5. Use the four large cap screws supplied with the linkage assembly to secure the motor to the adapter plate.

6. Add the ball joint assembly and push rod as shown in Fig. 10.

**Fig. 9—Relationship of parts in V51E.**

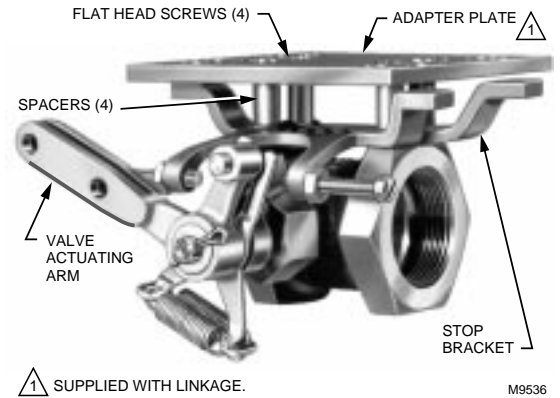

**Fig. 10—Typical combination of V51E, Air-O-Motor Pneumatic Actuator, and Q524 Linkage.**

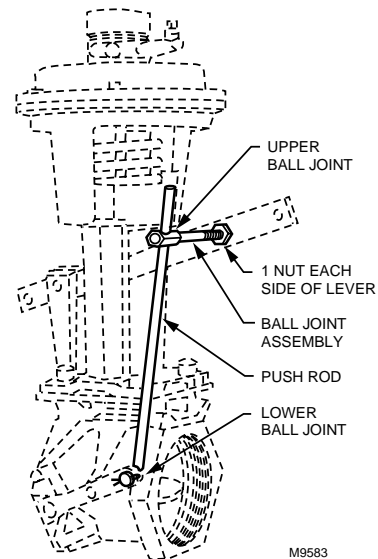

# Adjustments and Checkout

## MODUTROL MOTOR WITH Q100A LINKAGE AND V51E (FIG. 4)

### Minimum Flow Adjustment

Using the motor, drive the valve to the closed position. Loosen the lock nut on the stop screw. Turn this screw in against the operating lever until the desired minimum flow position is obtained. If fully closed is the minimum position desired, back the screw out until its threaded end is flush with the stop bracket. Tighten the lock nut.

### Maximum Flow Adjustment

With motor in closed position, loosen the lock nut on the stop screw. Turn this screw in against the operating lever until desired minimum flow position is obtained. If fully closed is the minimum position desired, back the screw out until it ends flush with the stop bracket. Tighten the lock nut.

## MODUTROL MOTOR WITH Q100B LINKAGE AND V51E (FIG. 5)

1. Loosen setscrews in upper ball joint to allow linkage rod to slide freely. Loosen lower ball joint so it slides freely in the actuating arm slot
2. Short the motor terminals red to white to drive the motor closed.
3. Hold valve butterfly open at the desired low-fire position and tighten the lower ball joint hand tight against the outer end of the actuating arm slot. Tighten screw in the upper ball joint enough to provide some friction on the rod, but not enough to prevent it from sliding if the valve reaches its stop
4. Short the motor terminals red to blue. As motor drives open, note the valve travel. Reset the lower ball joint to the proper high-fire valve position.

NOTE: When the lower ball joint is moved, the upper ball joint usually must be readjusted if the valve is to keep the same low-fire position

## ACTIONATOR MOTOR WITH Q100C LINKAGE AND V51E (FIG. 6)

### Minimum Flow Adjustments

Using the motor, drive valve to the open position. Loosen the lock nut on the stop screw. Turn this screw in against the operating lever until the desired maximum flow adjustment is obtained. If fully open is the maximum position desired, back out the screw until its threaded end is flush with the stop bracket. Tighten lock nut.

### Maximum Flow Adjustment

Using the motor, drive valve to the open position. Loosen the lock nut on the stop screw. Turn this screw in against the operating lever until the desired maximum flow adjustment is obtained. If fully open is the maximum position desired, back out the screw until its threaded end is flush with the stop bracket. Tighten lock nut.

## CHECKOUT

Cycle the burner twice through high-fire and low-fire while observing the actuating arm for smooth operation and watching the burner flame level for proper regulation of gas or air. Make certain the actuator arm does not hang up while the drive motor is in operation.

For detailed operation of drive motor and linkage, refer to applicable instructions furnished with the device.

# Maintenance

## PACKING THE VALVE

No field maintenance is required.

## LUBRICATION

Place a few drops of SAE20 or heavier oil on linkage bearings whenever required. The motor needs no lubrication in the field.

## MECHANICAL LINKAGES

Mechanical linkages may be devised to operate dampers or other valves in unison or sequence with this assembly. In no application should the combined load of the valve, damper, and linkage exceed the rated load limit of the motor for its timing. See applicable motor instructions.

**Home and Building Control**  
Honeywell Inc.  
1985 Douglas Drive North  
Golden Valley, MN 55422

**Home and Building Control**  
Honeywell Limited—Honeywell Limitée  
740 Ellesmere Road  
Scarborough, Ontario  
M1P 2V9

*Helping You Control Your World*

