

# VA-8020 Floating Valve Actuator

*The VA-8020 synchronous motor-driven actuator provides floating (three wire) control of valves with up to 5/16 inch stroke in Heating, Ventilating, and Air Conditioning (HVAC) applications. This compact, non-spring return actuator has a 22 lb minimum seating force in a compact, easy-to-install package.*

*The VA-8020 can be ordered factory coupled to VB-5x39 Flare Valves or VG7000 Brass Trim Valves for water service only. Refer to the appropriate valve literature for available configurations.*



**Figure 1: VA-8020 Floating Valve Actuator**

<b>Features and Benefits</b>	
<input type="checkbox"/> <b>Simplified Setup and Adjustment Procedures</b>	Reduces installation costs
<input type="checkbox"/> <b>Compact Assembly Size</b>	Fits most unit vent or baseboard applications
<input type="checkbox"/> <b>Slotted Stem Valve</b>	Provides ease of attachment
<input type="checkbox"/> <b>Synchronous Motor</b>	Meets a wide variety of small coil applications

## Operation

The VA-8020 actuator accepts a 24 VAC signal from a compatible controller. The controller sends 24 VAC to either the up or down wires depending on the desired movement of the valve. This signal drives the actuator motor causing the valve stem to move in the desired direction for the application. When the controller stops sending a signal, the valve stem remains in position.

The actuator uses a reversible synchronous motor to accurately position the valve. This can reliably generate 22 pounds of shutoff force in either the Drive Down or Drive Up direction.

Once the valve closes, a shutoff force builds up. When this force reaches 22 pounds, a lever within the actuator operates a force sensor that stops the motor. The constant load at the end of travel ensures tight valve seat shutoff and compensates for seat wear.

Field calibration of shutoff is not required. The actuator maintains the shutoff force even if power to the actuator is removed.

Note: The valve stem can be positioned manually by turning the adjustment knob shown in Figure 2. Rotating the knob counterclockwise moves the valve stem up.

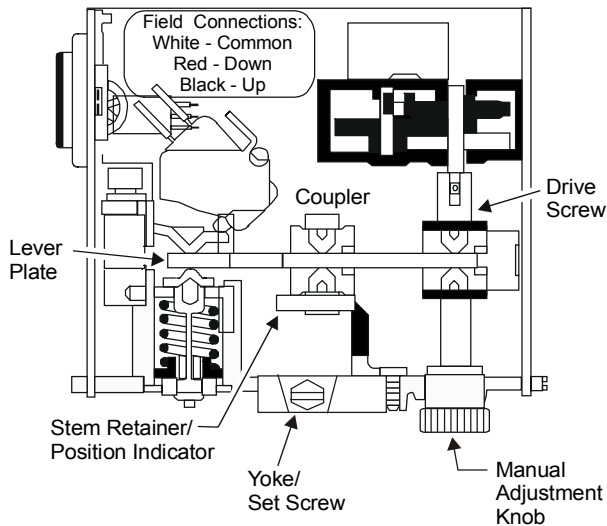

Figure 2: VA-8020 Components

**IMPORTANT:** There are no internal mechanical stops in the actuator. Never drive the actuator unless it is installed on the proper valve body, or the actuator may be damaged.

The actual full stroke time of the actuator in the system should be measured and entered into the controller.

Note: There is no direct correlation between valve position and controller output (0 to 100%) for floating control. If correlation is important, use an actuator with proportional control or position feedback.

## Dimensions

See Figure 3 for actuator dimensions.

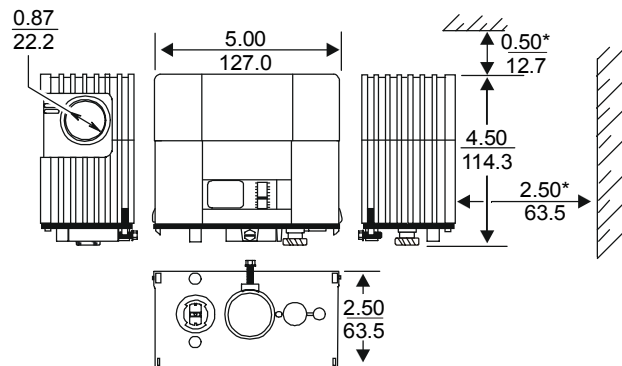

\* Dimensions required for cover removal.

Figure 3: VA-8020 Dimensions, in. (mm)

## Installation

**IMPORTANT:** Mount only on a valve that is piped within 90° of the vertical position, so dripping water is prevented from entering the actuator housing, since this could damage the actuator. Do not cover the actuator with thermal insulating material.

**Notes:** Slotted stem VG7000 valves can only be ordered factory mounted to a VA-8020 actuator. No adaptor kits are available.

The VA-8020-100 kit (ordered separately) is required if mounting to a VT Series Terminal Unit Valve.

### Kit Includes

- VA-8020 actuator
- VA-8020-605 stem retainer and clip kit
- Wire nuts (3)

### Tools Required

- 5/16 inch (8 mm) nut driver or 3/16 (5 mm) flat-blade screwdriver
- needle-nose pliers
- crescent wrench (to fit 1-1/4 in. bonnet adaptor nut)

**Note:** VA-8020-100 kit may be required if mounting to a VT valve.

## Mounting

**IMPORTANT:** Do not use on valves having a stroke over 5/16 in. Travel beyond 5/16 in. will damage the actuator or prevent complete shutoff.

**Note:** In horizontal piping applications, it is recommended that the valve be mounted within 85° of the upright position. When mounted in vertical piping, the valve must be protected from moisture.

Unpack the actuator and proceed as follows:

1. Remove the actuator cover by pressing inward on the plastic tabs while sliding the cover up and forward.
2. Make sure that the lever plate is within 1/4 in. (6.4 mm) of the upper stop. (See Figure 4.)

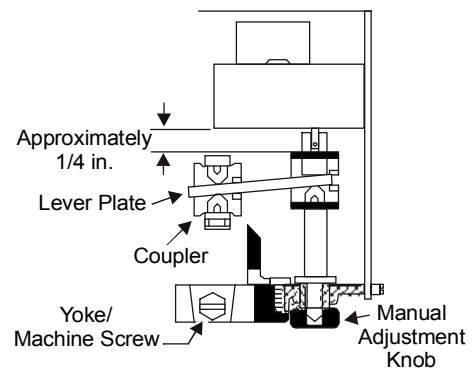

**Figure 4: Plate Position**

- For VT valves, thread the bonnet adaptor nut (included in the VA-8020-100 kit) onto the valve bonnet shown in Figure 5, and tighten with a wrench until it is snug.

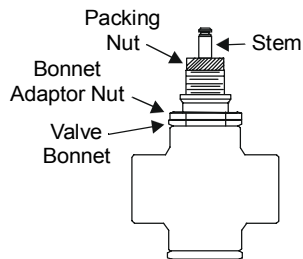

**Figure 5: Valve Bonnet Adaptor**

- Position the actuator yoke on the bonnet adaptor nut, making sure the yoke is flush with the surface of the nut.

**Note:** If the valve stem is touching the coupler and preventing a flush contact, use the manual adjustment knob (shown in Figure 2) to reposition the coupler.

- Secure the actuator to the valve bonnet by tightening the hex-head machine screw provided.

- Place the stem retainer and coupling clip over the valve stem, so the lower (shorter) portion of the coupling clip is positioned in the locking groove on the valve stem as shown in Figure 6.

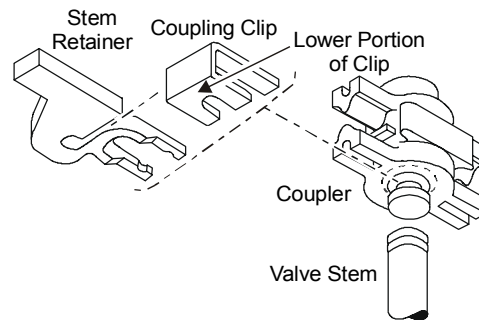

**Figure 6: VA-8020-605 Stem Retainer and Clip Kit**

**Note:** The extended portion of the stem retainer must be located on the right so that it lines up in the window of the cover. It may be necessary to pull the valve stem up to meet the coupler or to rotate the manual adjustment knob (shown in Figure 2) clockwise to run the coupler down.

- Push the white plastic stem retainer until the coupling clip moves forward into the groove, and the retainer locks the clip in place.
- Verify that the valve stem is located at the back of the groove by examining the connection.

To remove the coupling clip, use pliers to grip the stem retainer and pull outward. (See Figure 6.)

# Wiring

Input lines to the actuator must be wired correctly for the valve to move in the proper direction. (Refer to the specific controller wiring instructions as needed.) Wire the actuator as follows:

**CAUTION:** **Equipment Damage Hazard.** Disconnect all power supplies before wiring connections are made or prior to performing maintenance. Check all wiring connections before applying power to the system. Short-circuited or improperly connected wires will result in permanent damage to the equipment.

**IMPORTANT:** Make all wiring connections in accordance with the National Electrical Code and local regulations.

1. Push in the two tabs on the side of the cover, lift and remove the cover.
2. Locate the three wires with the stripped ends.
3. Use the wire nuts included to connect the leads from the actuator to the controller wiring.

4. Wire the actuator as shown in Figure 7.

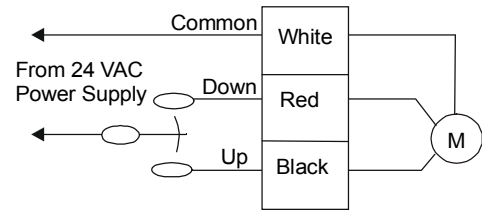

**Figure 7: Wiring for the VA-8020**

**Table 1: VA-8020 Action**

Energizing Wires	Actuator Drive Screw
White to Red	Down
White to Black	Up

Making contact to the down connection from the supply provides a signal path through the motor from the white and red wires, which will cause the actuator drive screw to drive the coupling down, pushing the valve stem down. Making contact to the up connection provides a signal path through the motor from the white and black wires, which will cause the actuator drive screw to drive the coupling up, pulling the valve stem up.

**IMPORTANT:** Parallel operation of VA-8020 actuators requires the use of isolation relays.

## Commissioning

Field calibration of the force sensor is not required.

If power is removed from the VA-8020, the actuator will remain in its intermediate position until the signal is applied again.

## Checkout

Once wiring is complete:

1. Provide a 24 VAC control signal to white and red wires. The actuator should drive the stem down, and the motor should stop.
2. Provide a 24 VAC control signal to white and black wires. The actuator should drive the stem up, and the motor should stop.
3. After manual operation, reset the controller.

The installation is complete.

## Ordering Information

Field repairs must not be made. To order a floating valve actuator, contact the nearest Johnson Controls representative and specify product code number VA-8020-1.

## Actuator Combinations

The VA-8020 is available factory coupled to VB-5x39 Flare Valves or VG7000 Brass Trim Valves. The VA-8020 is also available for retrofitting VG7000 Series bronze valves, VT Series Terminal Unit Valves (with slotted stems), and VB-5x39 Series Flare Valves. Refer to the *AV-8020 Series Floating Control Actuated Valve Product/Technical Bulletin (FAN 977 or 1628.3)*, and the *VG7000 Series Bronze Valves ANSI Class 250 (PN16) Body Size 1/2 through 2 inch (DN15 to DN50) Product/Technical Bulletin (FAN 977, 125, or 1628.3)* for available configurations. Accessories for the VA-8020 can be found in Table 2.

**Table 2: VA-8020 Accessories**

Product Code Number	Description
VA-8020-100	Mounting kit for VT valves
VA-8020-601	Replacement cover only
VA-8020-605*	Stem retainer and clip kit

\* One kit is included with the actuator. If ordered separately, it must be ordered in multiples of five.

---

## Notes

# Specifications

<b>Product</b>	VA-8020 Floating Valve Actuator
<b>Power Requirements</b>	20 to 30 VAC at 50/60 Hz; 3.4 VA supply minimum, Class 2
<b>Input Signal</b>	20 to 30 VAC, 50/60 Hz
<b>Input Impedance</b>	250 ohms, nominal
<b>5/16 inch Stroke Time</b>	50 Hz: Approximately 108 seconds nominal 60 Hz: Approximately 90 seconds nominal
<b>Shutoff Force</b>	22 lb (98 N) minimum
<b>Ambient Operating Conditions</b>	35 to 150°F (2 to 65°C); 85°F (30°C) maximum dew point at 90% RH, non-condensing
<b>Ambient Storage Conditions</b>	-40 to 150°F (-40 to 65°C); 85°F (30°C) maximum dew point at 90% RH, non-condensing
<b>Valve Media Temperature</b>	Water: 195°F (90°C) maximum Steam: Actuator is not rated for this application.
<b>Dimensions (H x W x D)</b>	4.5 x 5 x 2.5 in. (114 x 127 x 64 mm)
<b>Shipping Weight</b>	1.6 lb (0.74 kg)
<b>Agency Listings</b>	UL 873 Recognized, File E27734, Guide XAPX2 (Suitable for plenum use) CSA C22.2 No. 139 Certified, File LR85083, Class 3221 02

*The performance specifications are nominal and conform to acceptable industry standards. For application at conditions beyond these specifications, consult the local Johnson Controls office. Johnson Controls, Inc. shall not be liable for damages resulting from misapplication or misuse of its products.*



**Controls Group**  
507 E. Michigan Street  
P.O. Box 423  
Milwaukee, WI 53201

Printed in U.S.A.  
[www.johnsoncontrols.com](http://www.johnsoncontrols.com)