

VA9203-Bxx-2 Series On/Off Electric Spring Return Valve Actuators

Installation Instructions

Part No. 14-1380-16, Rev. —
Issued April 22, 2011

VA9203-BGA-2, VA9203-BGB-2, VA9203-BUA-2, VA9203-BUB-2

Refer to the [QuickLIT Web site](#) for the most up-to-date version of this document.

Applications

The VA9203-Bxx-2 Series On/Off Electric Spring Return Actuators are direct-mount valve actuators that operate on AC 24 V power at 50/60 Hz, DC 24 V power, or AC 85 to 264 V power at 50/60 Hz. These bidirectional actuators are used for on/off control on Johnson Controls® VG1000 Series 1/2, 3/4, and 1 in. (DN15, DN20, and DN25) ball valves in Heating, Ventilating, and Air Conditioning (HVAC) applications.

An integral line voltage auxiliary switch, available only on the VA9203-xxB-2 models, indicates end-stop position, or performs switching functions within the selected rotation range.

IMPORTANT: Use this VA9203 Series Valve Actuator only to control equipment under normal operating conditions. Where failure or malfunction of the VA9203 Series Valve Actuator could lead to personal injury or property damage to the controlled equipment or other property, additional precautions must be designed into the control system. Incorporate and maintain other devices, such as supervisory or alarm systems or safety or limit controls, intended to warn of or protect against failure or malfunction of the VA9203 Series Actuator.

Installation

Install the ball valve with the actuator at or above the center line of the horizontal piping (see Figure 1).

IMPORTANT: In steam applications, install the valve with the stem horizontal to the piping. Failure to follow this precaution may shorten the life of the actuator.

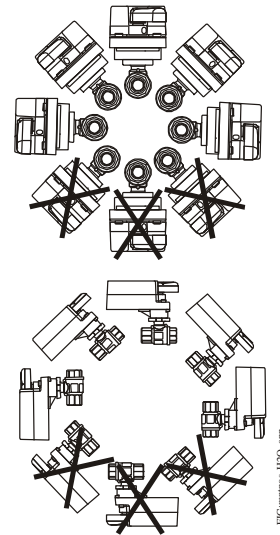

Figure 1: Mounting Positions for Chilled Water and Condensing Atmosphere Applications

IMPORTANT: Before specifying VA9203 Series Valve Actuators for plenum applications, verify acceptance of exposed plastic materials in plenum areas with the local building authority. Building codes for plenum requirements vary by location. Some local building authorities accept compliance to UL 1995, Heating and Cooling Equipment, while others use different acceptance criteria.

IMPORTANT: Do not install or use this VA9203 Series Valve Actuator in or near environments where corrosive substances or vapors could be present. Exposure of the actuator to corrosive environments may damage the device's internal components, and will void the warranty.

Special Tool Needed

- Johnson Controls M9000-200 Commissioning Tool or digital voltmeter
- T-20 TORX® driver

Dimensions

Valve Actuator

See Figure 2, Table 1, and Table 2 for dimensions of Spring Return VA9203 Series Actuated Ball Valves.

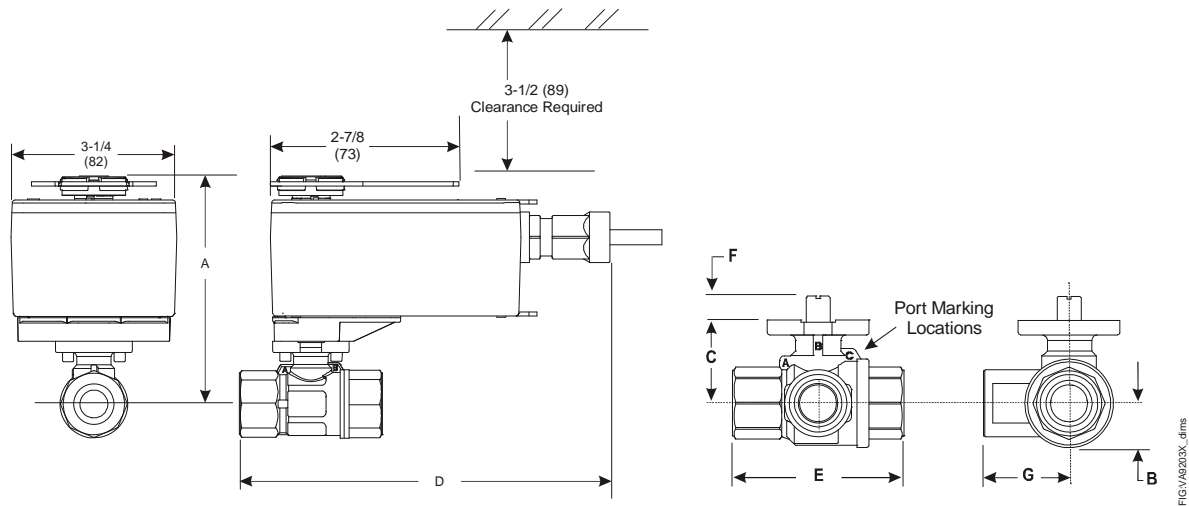

Figure 2: Spring Return VA9203 Actuated VG1241, VG1245, VG1841, and VG1845 Series Ball Valve Dimensions, in. (mm)

Table 1: VA9203 Actuated VG1241, VG1245, VG1841, and VG1845 Series NPT Ball Valve Dimensions, in. (mm)

Valve Size, in. (DN) ¹	A	B	C	D	E	F	G
1/2 (DN15)	4-5/8 (117)	21/32 (17)	1-7/32 (31)	6-31/32 (177)	2-33/64 (64)	11/32 (9)	1-1/4 (32)
3/4 (DN20)	4-5/8 (117)	21/32 (17)	1-7/32 (31)	7-1/8 (181)	2-51/64 (71)	11/32 (9)	1-13/32 (36)
1 (DN25)	4-11/16 (119)	3/4 (19)	1-19/64 (33)	7-31/64 (190)	3-13/32 (87)	11/32 (9)	1-45/64 (43)

1. Port A must always be connected to the coil.

Table 2: VA9203 Actuated VG1271, VG1275, VG1871, and VG1875 Series Sweat Ball Valve and VA9203 Actuated VG1291, VG1295, VG1891, and VG1895 Series Press Ball Valve Dimensions, in. (mm)

Valve Size, in. (DN) ¹	A	B	C	D	E	F	G
1/2 (DN15)	4-5/8 (117)	21/32 (17)	1-7/32 (31)	7-13/64 (183)	3-25/32 (96)	11/32 (9)	1-1/4 (32)
3/4 (DN20)	4-5/8 (117)	21/32 (17)	1-7/32 (31)	7-3/4 (197)	4-3/32 (104)	11/32 (9)	1-13/32 (36)
1 (DN25)	4-23/32 (120)	3/4 (19)	1-19/64 (33)	8-3/16 (208)	4-41/64 (118)	11/32 (9)	1-45/64 (43)

1. Port A must always be connected to the coil.

Valve Actuator with Thermal Spacer

See Figure 3 and Table 3 for valve actuator dimensions with optional M9000-561 Thermal Barrier installed.

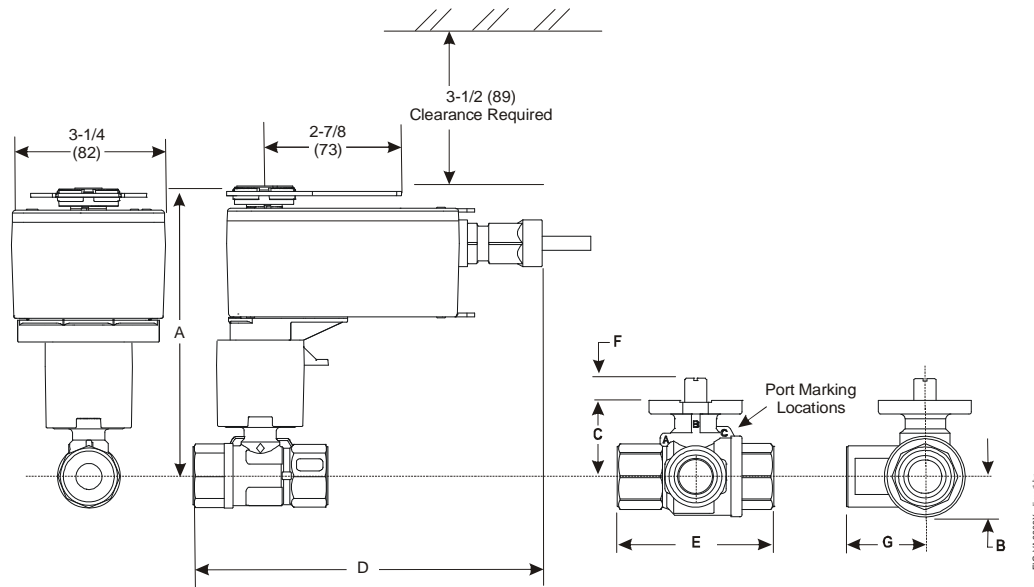

Figure 3: Spring Return VA9203 Actuated VG1241, VG1245, VG1841, and VG1845 Series Ball Valve with Optional M9000-561 Thermal Barrier Installed Dimensions, in. (mm)

Table 3: VA9203 Actuated VG1241, VG1245, VG1841, and VG1845 Series NPT Ball Valve with Optional Thermal Barrier Installed Dimensions, in. (mm)

Valve Size, in. (DN) ¹	A	B	C	D	E	F	G
1/2 (DN15)	6 (152)	21/32 (17)	1-7/32 (31)	6-31/32 (177)	2-33/64 (64)	11/32 (9)	1-1/4 (32)
3/4 (DN20)	6 (152)	21/32 (17)	1-7/32 (31)	7-1/8 (181)	2-51/64 (71)	11/32 (9)	1-13/32 (36)
1 (DN25)	6-1/16 (154)	3/4 (19)	1-19/64 (33)	7-31/64 (190)	3-13/32 (87)	11/32 (9)	1-45/64 (43)

1. Port A must always be connected to the coil.

Accessories

Table 4: Accessories (Order Separately)

Code Number	Description
M9000-200	Commissioning Tool That Provides a Control Signal to Drive 24 V On/Off, Floating, Proportional, and/or Resistive Electric Actuators
M9000-560	Ball Valve Linkage Kit for Applying M9203 and M9208 Series Actuators to VG1000 Series Valves (Quantity 1)
M9000-561	Thermal Barrier Extends M(VA)9104, M(VA)9203, and M(VA)9208 Series Electric Spring Return Actuator Applications to Include Low Pressure Steam (Quantity 1)
M9000-341	Weathershield Kit for VG1000 Series Ball Valve Application of M(VA)9104, M(VA)9203, and M(VA)9208 Series Electric Spring Return Actuators (Quantity 1)
M9000-607	Position Indicator for VG1000 Series Ball Valve Applications (Quantity 5)

Mounting

Mounting the Actuator to Spring Return Port A (Coil) Open

To mount the actuator to spring return Port A (coil) open:

1. Turn the valve stem to the position outlined in Figure 4.

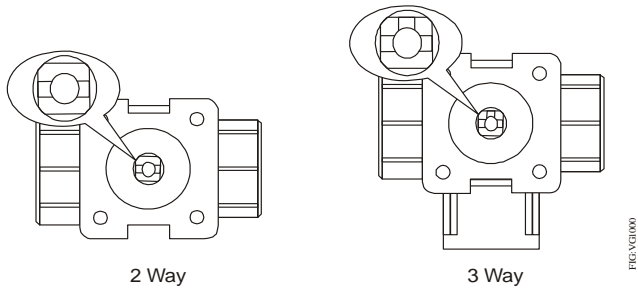

Figure 4: Positioning the Valve Stem

2. Mount optional M9000-561 Thermal Barrier to the valve if fluid temperature exceeds 212°F (100°C). See the [Mounting the Thermal Barrier](#) section for more information.

Note: Proceed to Step 7 if the ball valve linkage is on actuator Side B.

3. Remove the linkage from Side A (Figure 5).

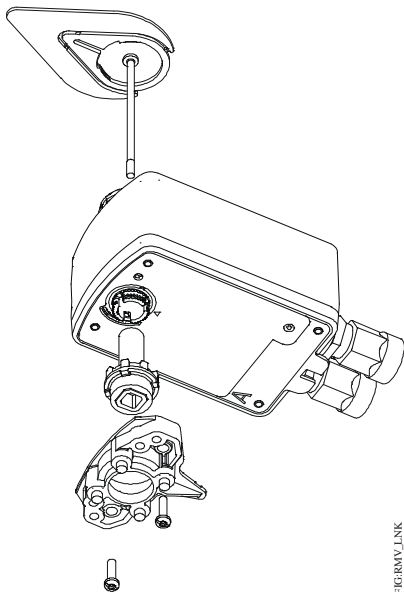

Figure 5: Removing the Linkage

4. Insert the drive shaft into Side B (Figure 6). The drive shaft is keyed for one-way assembly. With gentle pressure applied, rotate the drive shaft until the key aligns and the drive shaft falls into place.

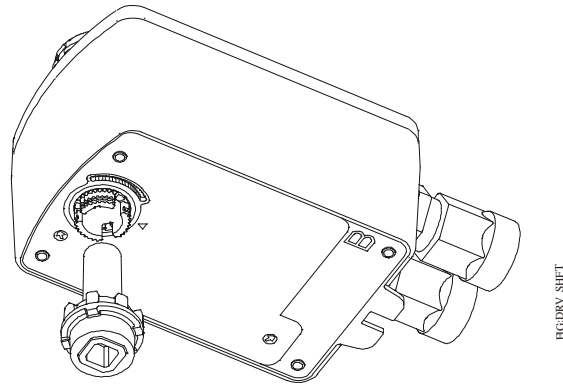

Figure 6: Inserting the Drive Shaft

5. Install linkage base on Side B using the two #8-32 x 0.625 in. long screws (Figure 7). The recommended torque is 29 to 33 lb-in. (3.3 to 3.7 N·m).

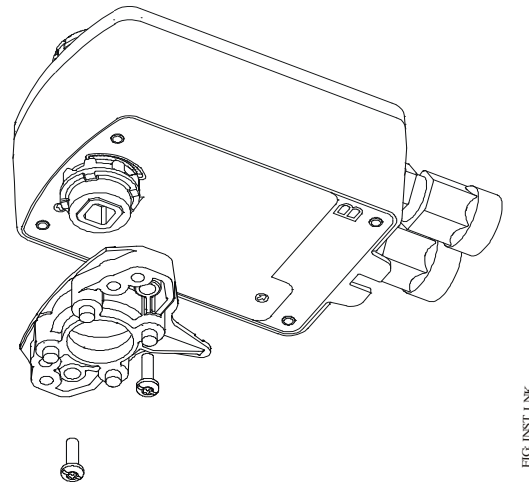

Figure 7: Installing the Linkage

6. Insert fixed pointer and M4x0.7x83 mm long screw into the Side A actuator hub (Figure 8). Direct the arrow on the pointer to 100%.

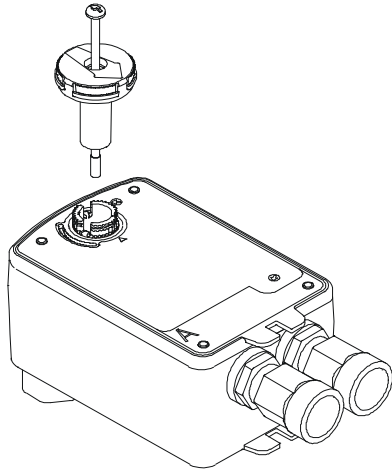

Figure 8: Installing the Fixed Pointer

7. Install the actuator on the ball valve (Figure 9). Tighten the actuator mounting screw to a torque of 10 to 12 lb-in. (1.1 to 1.4 N·m) and snap the large adjustable pointer into place.

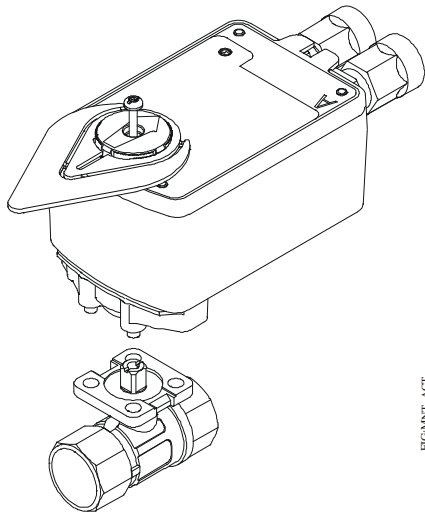

Figure 9: Mount the Actuator

Mounting the Actuator to Spring Return Port A (Coil) Closed

To mount the actuator to spring return Port A (coil) closed:

1. Turn the valve stem to the position outlined in Figure 10.

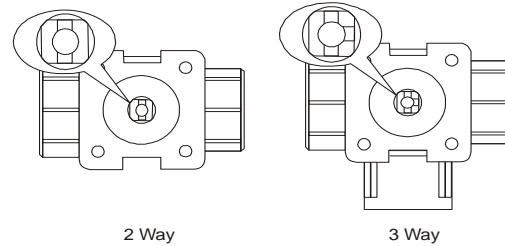

Figure 10: Positioning the Valve Stem

2. Mount optional M9000-561 Thermal Barrier to the valve if fluid temperature exceeds 212°F (100°C). See the *Mounting the Thermal Barrier* section for more information.

Note: Proceed to Step 7 if the ball valve linkage is on actuator Side A.

3. Remove the linkage from Side B (Figure 13).

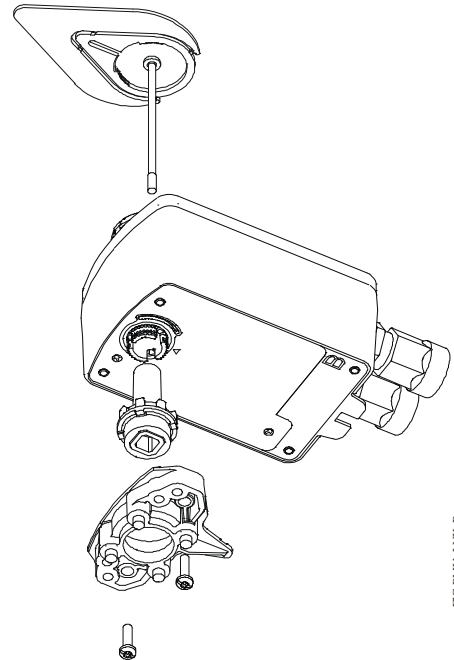

Figure 11: Removing the Linkage

4. Insert the drive shaft into Side A (Figure 12). The drive shaft is keyed for one-way assembly. With gentle pressure applied, rotate the drive shaft until the key aligns and the drive shaft falls into place.

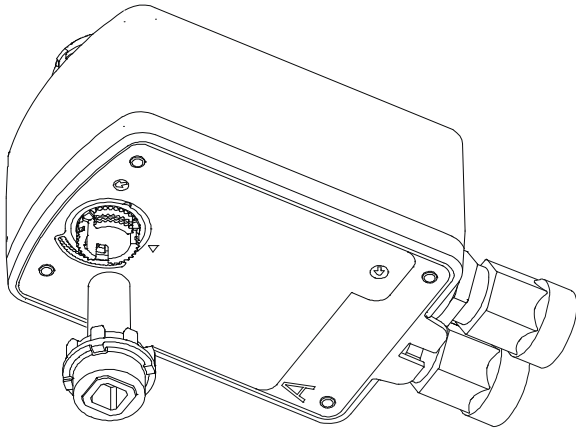

Figure 12: Inserting the Drive Shaft

5. Install linkage base on Side A using the two #8-32 x 0.625 in. long screws (Figure 13). The recommended torque is 29 to 33 lb-in. (3.3 to 3.7 N-m).

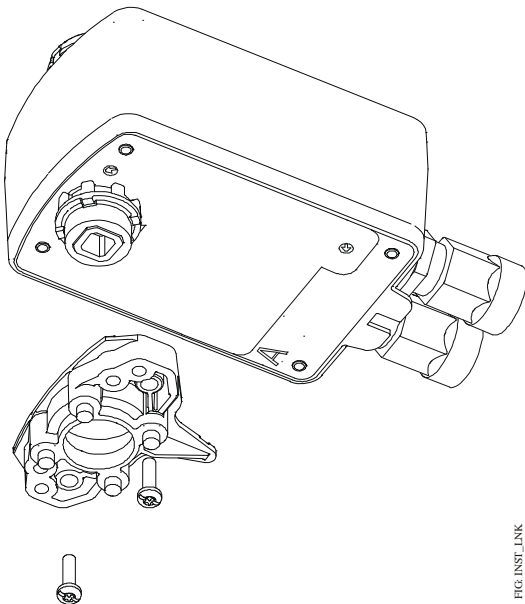

Figure 13: Installing the Linkage

6. Insert fixed pointer and M4x0.7x83 mm long screw into the Side B actuator hub (Figure 14). Direct the arrow on the pointer to 0%.

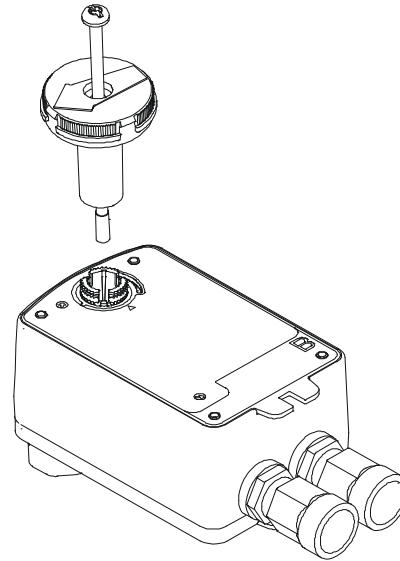

Figure 14: Installing the Fixed Pointer

7. Install the actuator on the ball valve (Figure 15). Tighten the actuator mounting screw to a torque of 10 to 12 lb-in. (1.1 to 1.4 N-m) and snap the large adjustable pointer into place.

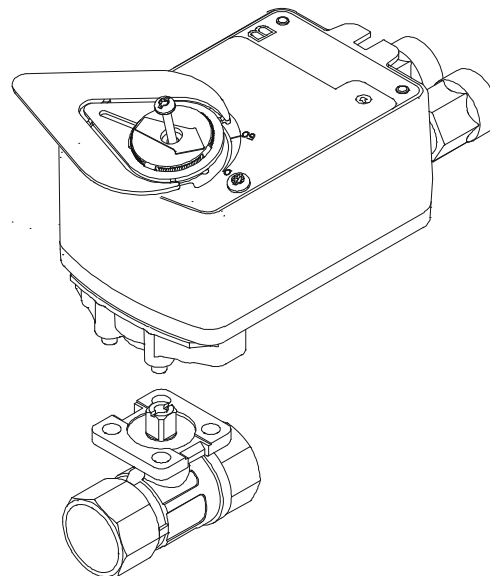

Figure 15: Mount the Actuator

Mounting the Thermal Barrier

Figure 16 shows the optional M9000-561 Thermal Barrier.

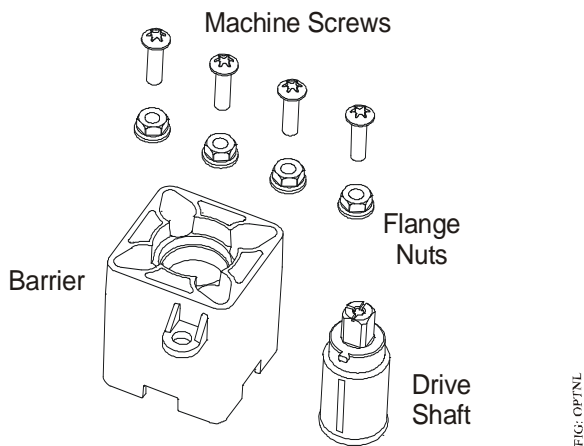

Figure 16: Optional M9000-561 Thermal Barrier

To mount the optional thermal barrier:

1. Install the thermal barrier drive shaft into the thermal barrier by aligning the tab on the drive shaft with the slot on the thermal barrier (Figure 17).

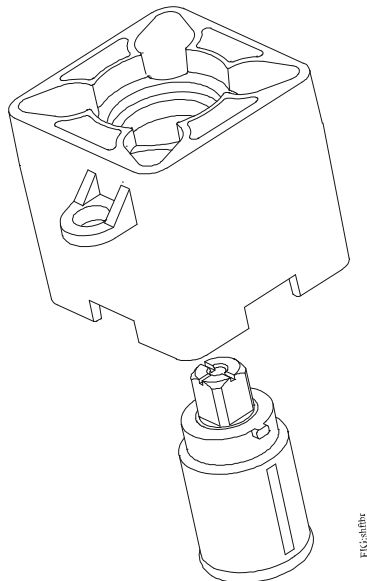

Figure 17: Installing the Drive Shaft into the Thermal Barrier

2. Rotate the drive shaft to align marks on the top of the thermal drive shaft with matching marks on the valve stem.
3. Mount the thermal barrier onto the valve using the four included M5x16 mm machine screws and four M5 flange nuts. Tighten the screws to a recommended torque of 21 to 25 lb-in. (2.4 to 2.8 N·m) (Figure 18).

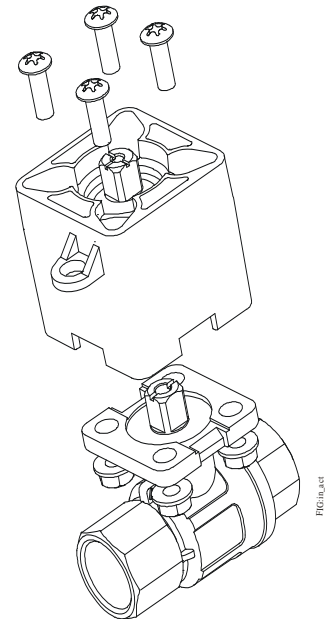

Figure 18: Installing the Barrier

4. Proceed to actuator mounting instructions. Follow the same steps as mounting directly to the valve when mounting the actuator to the thermal barrier.

Wiring

See Figure 19 and Figure 20 to wire the applicable VA9203-Bxx-2 Series model.

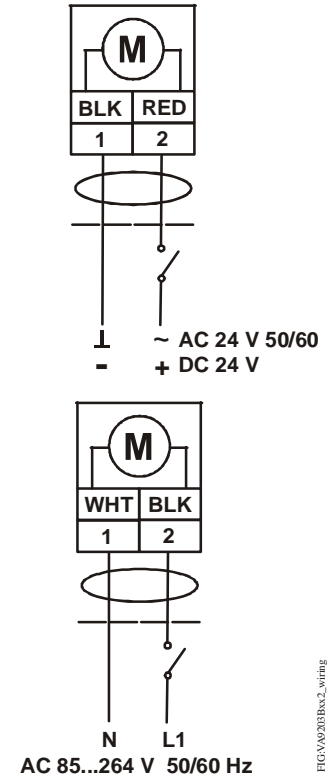

Figure 19: Control Wiring Diagrams

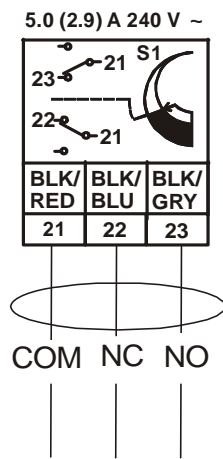

Figure 20: Optional Auxiliary Switch Wiring



WARNING: Risk of Electric Shock.

Disconnect or isolate all power supplies before making electrical connections. More than one disconnect or isolation may be required to completely de-energize equipment. Contact with components carrying hazardous voltage can cause electric shock and may result in severe personal injury or death.



CAUTION: Risk of Property Damage.

Do not apply power to the system before checking all wiring connections. Short circuited or improperly connected wires may result in permanent damage to the equipment.



CAUTION: Risk of Property Damage.

Insulate and secure each unused wire lead before applying power to the actuator. Failure to insulate and secure each unused wire lead may result in property damage.

IMPORTANT: Make all wiring connections in accordance with the National Electrical Code and local regulations. Use proper Electrostatic Discharge (ESD) precautions during installation and servicing to avoid damaging the electronic circuits of the actuator.

Using Conduit

All VA9203 Series Actuators accept 1/2 in. threaded electrician's fittings (Figure 21).

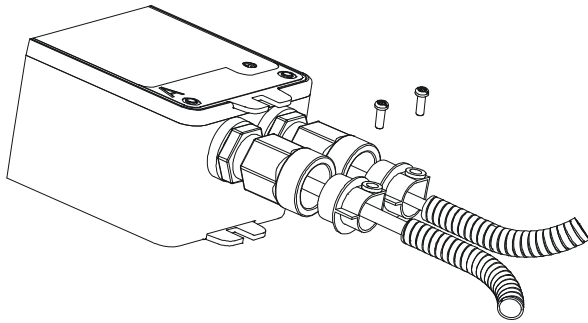

Figure 21: Adding Flexible Metal Conduit

1. Feed the actuator cables through the field-supplied electrician's fitting and conduit.
2. Thread the electrician's fitting into the actuator and secure the conduit to the fitting in accordance with local building code requirements.

Setup and Adjustments

Auxiliary Switch (VA9203-xxB-xx Models)

The VA9203-xxB-xx models include one integral auxiliary switch with a switch adjuster accessible on either face of the actuator (Figure 22). The factory setting for Auxiliary Switch is 10% closing (relative to the 0 to 100% rotation range as printed on the product label). See the *Technical Specifications* section for the auxiliary switch ratings.



WARNING: Risk of Electric Shock and Property Damage.

Insulate and secure each unused wire lead before applying power to the actuator. Failure to insulate and secure each unused wire lead may result in property damage, electric shock, and severe personal injury or death.

The switch point is continuously adjustable throughout the actuators' rotation range. For the most accurate switch positioning, see Figure 22 and use the method in the following example. To change the switch point of auxiliary switch, proceed as follows:

1. Position the actuator in the full spring return position.

Note: The switch is factory set to trip when the actuator reaches the 10% position.

2. Rotate the switch adjuster until it points to the desired switch point.
3. Connect the auxiliary switch to a power source or an ohmmeter and apply power to the actuator. The actuator moves to the fully open position and holds while power is applied.
4. Observe the switch point. If required, repeat Step 1 through Step 3.

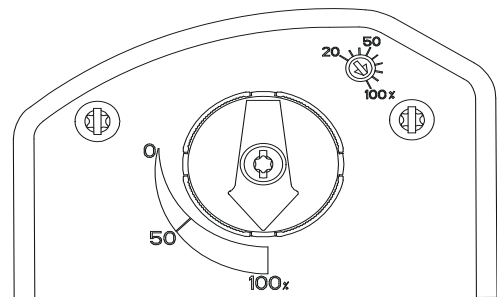



Figure 22: Switch Trip Point Settings

Technical Specifications

VA9203-Bxx-x Series On/Off Electric Spring Return Actuator (Part 1 of 2)

Power Requirements	-BGx-2 Models	AC 24 V (AC 19.2 V to 28.8 V) at 50/60 Hz: Class 2 (North America) or Safety Extra-Low Voltage (SELV) (Europe), 5 VA Running, 1.6 VA Holding Position DC 24 V (DC 21.6 V to 28.8 V): Class 2 (North America) or SELV (Europe) 2.8 W Running, 0.8 W Holding Position Minimum Transformer Size: 6 VA per Actuator
	-BUx-2 Models	AC 100 V to 240 V (AC 85 V to 264 V) at 50/60 Hz: 0.06 A Running, 0.02 A Holding Position
Auxiliary Switch Rating	-xxB-2 Models	One Single-Pole, Double-Throw (SPDT), Double-Insulated Switch with Silver Contacts: AC 24 V, 50 VA Pilot Duty AC 120 V, 5.8 A Resistive, 1/4 hp, 275 VA Pilot Duty AC 240 V, 5.0 A Resistive, 1/4 hp, 275 VA Pilot Duty
Spring Return		Direction is Selectable with Mounting Position of Actuator: Actuator Face Labeled A is Away from Valve: CCW Spring Return Actuator Face Labeled B is Away from Valve: CW Spring Return
Rated Torque	Power On (Running)	27 lb-in. (3 N-m) All Operating Temperatures
	Power Off (Spring Returning)	27 lb-in. (3 N-m) All Operating Temperatures
Rotation Range		Maximum Full Stroke: 95°
Rotation Time for 90 Degrees of Travel	Power On (Running) Bxx-2 Models	53 to 71 Seconds Constant for 0 to 27 lb-in. (3 N-m) Load, at Room Temperature 60 Seconds Nominal at Full Rated Load (0.25 rpm)
	Power Off (Spring Returning)	19 to 23 Seconds for 0 to 27 lb-in. (3 N-m) Load, at Room Temperature 22 Seconds Nominal at Full Rated Load 28 Seconds Maximum with 27 lb-in. (3 N-m) Load at -22°F (-30°C)
Life Cycles		60,000 Full Stroke Cycles with 27 lb-in. (3 N-m) Load
Audible Noise Rating	Power On (Running)	<36 dBA at 70 lb-in. (8 N-m) Load, at a Distance of 39-13/32 in. (1 m)
	Power On (Holding)	<20 dBA at a Distance of 39-13/32 in. (1 m)
	Power Off (Spring Returning)	<51 dBA at 70 lb-in. (8 N-m) Load, at a Distance of 39-13/32 in. (1 m)
Electrical Connections	Actuator (All Models)	48 in. (1.2 m) UL 758 Type AWM Halogen Free Cable with 18 AWG (0.85 mm ²) Conductors and 0.25 in. (6 mm) Ferrule Ends
	Auxiliary Switches (-xxB-2 Models)	48 in. (1.2 m) UL 758 Type AWM Halogen Free Cable with 18 AWG (0.85 mm ²) Conductors and 0.25 in. (6 mm) Ferrule Ends
Conduit Connections		Integral 1/2 in. (13 mm) Threaded Conduit Connectors
Fluid Temperature Limits	VG12x1 and VG18x1 Series	23 to 203°F (-5 to 95°C), Not Rated for Steam Service
	VG12x5 and VG18x5 Series	-22 to 212°F (-30 to 100°C), Not Rated for Steam Service
	VG12x5 and VG18x5 Series with M9000-561 Thermal Barrier Installed	-22 to 284°F (-30 to 140°C) water; 15 psig (103 kPa) at 250°F (121°C) Saturated Steam

VA9203-Bxx-x Series On/Off Electric Spring Return Actuator (Part 2 of 2)

Ambient Conditions	Standard Operating	-22 to 140°F (-30 to 60°C); 90% RH Maximum, Noncondensing
	Storage	-40 to 185°F (-40 to 85°C); 95% RH Maximum, Noncondensing
Enclosure Rating		NEMA 2 (IP54) for all Mounting Directions
	United States	UL Listed, CCN XAPX, File E27734; to UL 60730-1A: 2003-08, Ed. 3.1, Automatic Electrical Controls for Household and Similar Use; and UL 60730-2-14: 2002-02, Ed. 1, Part 2 Particular Requirements for Electric Actuators
	Canada	UL Listed, CCN XAPX7, File E27734; to UL 60730-1:02-CAN/CSA: July 2002, 3rd Ed., Automatic Electrical Controls for Household and Similar Use; and CSA C22.2 No. 24-93 Temperature Indicating and Regulating Equipment
	Europe	CE Mark – Johnson Controls, Inc., declares that this product is in compliance with the essential requirements and other relevant provisions of the EMC Directive 2004/108/EC and the Low Voltage Directive 2006/95/EC.
	Australia and New Zealand	C-Tick Mark, Australia/NZ Emissions Compliant
Shipping Weight	-xxA Models	2.0 lb (0.9 kg)
	-xxB Models	2.4 lb (1.1 kg)



Building Efficiency

507 E. Michigan Street, Milwaukee, WI 53202

Metasys® and Johnson Controls® are registered trademarks of Johnson Controls, Inc. All other marks herein are the marks of their respective owners. © 2011 Johnson Controls, Inc.