

## VBN2, VBN3 Control Ball Valves With Threaded Connections

### INSTALLATION INSTRUCTIONS

#### APPLICATION

The VBN2 Two-Way and the VBN3 Three-Way Control Ball Valves control hot and chilled water with glycol solutions up to 50% in heating, ventilating, and air conditioning (HVAC) systems to provide two-position or modulating functions.

These valve assemblies can be ordered with or without factory-mounted non-spring return or spring return direct-coupled actuators (DCA).

#### Application Notes

##### IMPORTANT

*Valve sizing is important for correct system operation. Undersized valves do not have sufficient capacity at maximum load. Oversized valves do not have sufficient authority over the load in modulating applications.*

*Oversized valves can cause excessive cycling and the seat and ball can be damaged because of the restricted opening.*

#### Proper Use

These valves are only for use in cold, warm, hot water systems and for steam applications. They are designed for a medium temperature range of from 35 to 250°F, at a maximum pressure of 360 psig VBN valves are to be operated with the appropriate Honeywell direct coupled actuators only.

Water should be properly filtered, treated and conditioned according to local conditions and the recommendations of the boiler or chiller manufacturers. The installation of a strainers and filters is recommended.

##### IMPORTANT

*The presence of excessive iron oxide (red rust) in the system voids the valve warranty.*

#### Effective $C_v$

When valves are mounted between pipe reducers, there is a decrease in actual valve capacity because the reducers create additional pressure losses in the system. This is especially true for ball valves because of their high capacity.

For effective  $C_v$ s for Honeywell control ball valves when used with pipe reducers, refer to the Product Data sheet form no. 62-2648.

#### Flow Characteristics

The VBN2 Two-Way Ball Valves have:

- an equal percentage flow characteristic with characterized flow control insert.
- a linear flow characteristic with full port balls.

The VBN3 Three-Way Ball Valves have:

- between ports A and AB: an equal percentage flow characteristic.
- between ports B and AB: a linear flow characteristic.

#### Required Operating Torque

Both Honeywell non-spring return and spring return low torque direct coupled actuators can be utilized with the VBN2 and VBN3 valves. VBN valves use a patented seat design that reduces the torque needed from the actuator. A 35 lb-in. DCA provides sufficient torque to close the valve at rated close-off. (See Table 1.) These ratings exceed most HVAC application requirements.

Table 1. Close-off, Differential Pressure Ratings.

Valve Type	Valve Size	Close-off Pressure Rating (psi)
2 way	1/2", 3/4"	130
	1", 1-1/4", 1-1/2", 2", 2-1/2", 3"	100
3 way	1/2", 3/4", 1"	50
	1-1/4", 1-1/2", 2", 2-1/2"	40

## INSTALLATION

### When Installing this Product...

1. Read these instructions carefully. Failure to follow them could damage the product or cause a hazardous condition.
2. Check ratings given in instructions and on the product to ensure the product is suitable for your application.
3. Installer must be a trained, experienced service technician.
4. After installation is complete, check out product operation as provided in these instructions.



## Preparation

### CAUTION

#### Equipment Damage Hazard

Foreign particles like dirt and metal chips can damage the ball seals.

For trouble-free operation of the product, good installation practice must include initial system flushing, and chemical water treatment. Clean the lines upstream of particles larger than 1/16 inch diameter (welding slag, pipe scale, sand and other suspended particulate). Use of a 50 micron (or finer) system side stream filter is suggested. Remove all filters before flushing.

Do not use boiler additives, solder flux and wetted materials which are petroleum based or contain mineral oil, hydrocarbons, or ethylene glycol acetate. Compounds which can be used, with minimum 50% water dilution, are diethylene glycol, ethylene glycol, and propylene glycol (antifreeze solutions).

If installing these valves in an addition to, or retrofitting an existing building, do not assume that the fluid in the existing piping meets these criteria.

#### IMPORTANT:

*Hold valve with pipe wrench by hexagonal fitting ONLY. Do NOT handle the valve body with the pipe wrench; product damage may result.*

1. Clean the lines upstream of particles larger than 1/16 in. diameter (welding slag, pipe scale and other contaminants).
2. Proceed with installation once the system specifics (expansion/contraction of the system and its medium as well as operating pressures) are within tolerances.
3. Eliminate air from system.
4. Two-way valves are marked to show flow direction.

#### IMPORTANT

*Flow arrows must point in the direction of the flow for proper operation.*

NOTE: For three-way valve mounting, see Fig. 1 and 2.

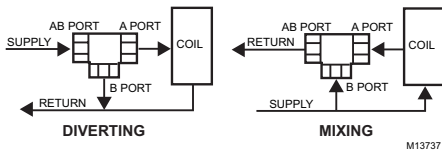

Fig. 1. Three-way ball valve flow orientation (not to scale).

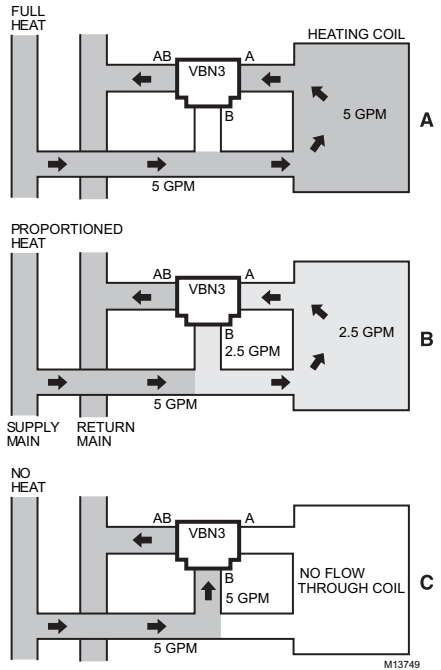

Fig. 2. Three-way mixing valve operation with coil bypass.

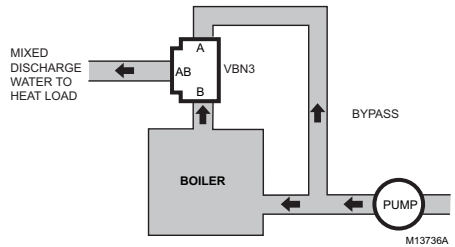

Fig. 3. Boiler bypass for reset control.

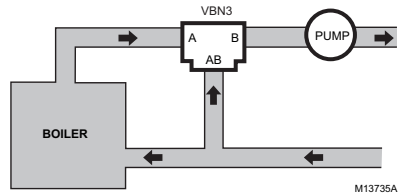

Fig. 4. Supply mixing for reset control.

5. Stem rotation:
  - a. For two-way valves:
    - (1) Clockwise to close.
    - (2) Counterclockwise to open.
  - b. For three-way valves:
    - (1) Clockwise to increase B to AB flow.
    - (2) Counter clockwise to increase A to AB flow.

**NOTE:** After valves have been installed in the piping, the installer can determine the ball orientation within the valve from the notches in the top of the valve stem. For two-way valves, the lengthwise direction of the notch indicates the flow through the ball (i.e. when the notch is parallel to the axis of the valve between A and B ports, the ball will allow flow through the valve). For three-way valves, the flow can be determined by the orientation of the "T" shaped notch in the valve stem, as shown in Fig. 5.

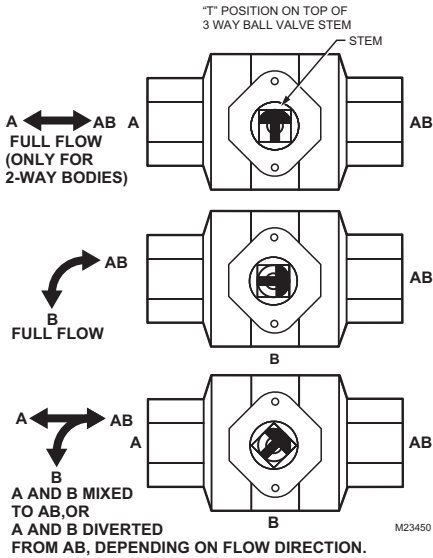

Fig. 5. Orientation of ball in valve

6. Valve must be mounted with the actuator/bracket above the valve body. Do not install the valve with the stem below horizontal or upside down. (See Fig. 6 and 7.)

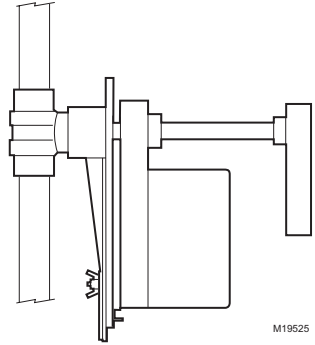

Fig. 6. Vertical valve installation

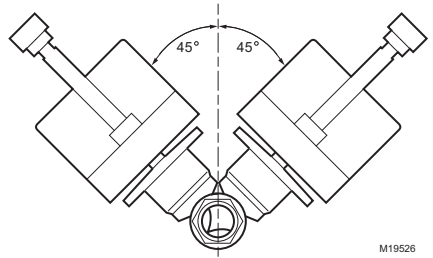
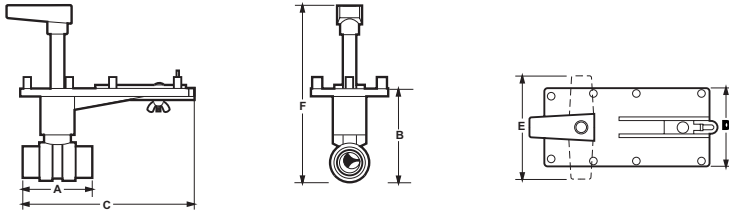

Fig. 7. Acceptable valve angle from vertical

### Mechanical Installation

The valves are tapped in NPT and should be sealed with an approved pipe sealant. Torque should not exceed 75 lb-ft.

See Fig. 8 and 9 for valve dimensions. Refer to actuator literature for actuator dimensions.



Pipe Size	Model No.	C <sub>V</sub>	Dimensions inches (mm)						Weight lb (kg)
			A	B	C	D	E	F	
1/2"	VBN2A	0.38, 0.68, 1.3, 2.0, 2.6, 4.7, 11.7	2-3/8 (60)	3-7/16 (87)	6-5/8 (168)	3 (76)	4 (102)	8-1/8 (206)	1 (0.5)
		8.0	2-5/8 (67)	3-11/16 (94)	6-1/2 (165)	3 (76)	4 (102)	8-5/16 (211)	1 (0.5)
3/4"	VBN2B	0.31, 0.63, 1.2, 2.5, 4.3, 7.4, 14.7	2-3/8 (60)	3-7/16 (87)	6-7/16 (164)	3 (76)	4 (102)	8-1/8 (206)	1 (0.5)
		10.1, 29	2-5/8 (67)	3-11/16 (94)	6-1/2 (165)	3 (76)	4 (102)	8-5/16 (211)	1 (0.5)
1"	VBN2C	9.0	3-3/4 (95)	3-11/16 (94)	7-1/16 (179)	3 (76)	4 (102)	8-5/16 (211)	1 (0.5)
		4.4, 15.3, 54	3 (76)	3-15/16 (100)	6-3/4 (171)	3 (76)	4 (102)	8-11/16 (221)	1.4 (0.6)
		26, 44	4-3/8 (111)	4-7/16 (113)	7-3/8 (187)	3 (76)	4 (102)	8-7/8 (225)	2.4 (1.1)
1-1/4"	VBN2D	4.4, 8.3, 14.9, 25, 41	3 (76)	3-15/16 (100)	6-11/16 (170)	3 (76)	4 (102)	8-11/16 (221)	1.4 (0.6)
1-1/2"	VBN2E	37, 102	3-5/8 (92)	4-7/16 (113)	7 (178)	3 (76)	4 (102)	9-1/16 (231)	2.4 (1.1)
		23, 30, 74	3-3/8 (86)	3-15/16 (100)	6-15/16 (176)	3 (76)	4 (102)	9-1/16 (231)	2.4 (1.1)
2"	VBN2F	41, 172	3-3/4 (95)	5-3/16 (132)	7-1/16 (179)	3 (76)	4 (102)	8-7/8 (225)	3.2 (1.5)
		42, 108	4 (102)	5-3/16 (132)	7-3/16 (183)	3 (76)	4 (102)	8-7/8 (225)	3.2 (1.5)
		57, 71, 100, 210, 266	4-3/8 (111)	5-3/4 (146)	7-7/16 (189)	3 (76)	4 (102)	10-1/2 (267)	5 (2.3)
2-1/2"	VBN2G	45, 55, 72, 101, 162, 202	4-3/4 (121)	5-3/4 (146)	7-9/16 (192)	3 (76)	4 (102)	10-1/2 (267)	5.5 (2.5)
3"	VBN2H	49, 63, 82, 124, 145	5 (127)	5-7/8 (149)	7-11/16 (195)	3 (76)	4 (102)	10-11/16 (271)	5.9 (2.7)

M23550

Fig. 8. VBN2 dimensions in inches (millimeters).

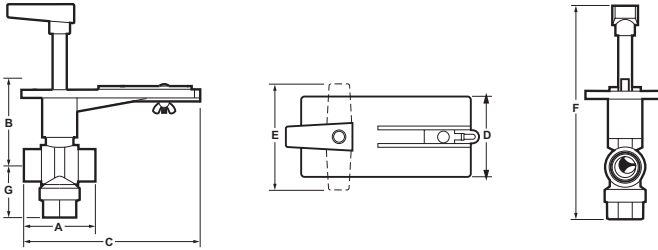

Pipe Size	Model No.	C <sub>V</sub>	Dimensions inches (mm)						Weight lb (kg)	
			A	B	C	D	E	F		G
1/2"	VBN3A	0.33, 0.59, 1.0, 2.4, 4.3, 8.0	3-1/2 (90)	3-5/16 (84)	7 (178)	3 (76)	4 (102)	9-3/8 (238)	2-3/8 (60)	2.4 (1.1)
3/4"	VBN3B	0.40, 0.66, 1.3, 2.4, 3.8, 7.0, 11.0	2-13/16 (71)	3-5/16 (84)	6-1/2 (168)	3 (76)	4 (102)	8-13/16 (224)	2 (51)	2 (0.9)
1"	VBN3C	0.40, 0.65, 1.3, 2.3, 3.5	3-13/16 (97)	3-5/16 (84)	7-5/16 (186)	3 (76)	4 (102)	9-1/2 (241)	2-3/4 (70)	2.8 (1.3)
		8.6, 22	3 (76)	3-13/16	6-13/16 (173)	3 (76)	4 (102)	9-13/16 (249)	2-5/8 (67)	2.6 (1.2)
1-1/4"	VBN3D	4.5, 14.9, 31	4-1/2 (114)	4 (102)	7-13/16 (193)	3 (76)	4 (102)	10-13/16 (275)	3-1/4 (83)	3.3 (1.5)
		4.1, 8.7, 19.0	3 (76)	3-13/16	6-13/16 (173)	3 (76)	4 (102)	9-13/16 (249)	2-1/2 (64)	2.5 (1.1)
1-1/2"	VBN3E	12.7, 27, 34	3-5/8 (92)	4 (102)	7-5/16 (186)	3 (76)	4 (102)	10-5/16 (262)	2-3/4 (70)	2.8 (1.3)
		4.0, 8.3, 13.4, 32	4-1/2 (114)	4 (102)	7-13/16 (198)	3 (76)	4 (102)	10-13/16 (275)	3-1/4 (83)	3.3 (1.5)
2"	VBN3F	24, 61	4 (102)	4-1/2 (114)	7-5/16 (186)	3 (76)	4 (102)	11 (279)	3-1/4 (83)	3.3 (1.5)
		24, 38, 57	4 (102)	4-1/2 (114)	7-5/16 (186)	3 (76)	4 (102)	11 (279)	3-1/4 (83)	3.3 (1.5)
2-1/2"	VBN3G	83, 109	5 (127)	5-13/16	7-13/16 (198)	3 (76)	4 (102)	12-5/16 (313)	3-3/4 (95)	3.8 (1.7)
		38, 74, 100	5 (127)	5-13/16	7-13/16 (198)	3 (76)	4 (102)	12-5/16 (313)	3-3/4 (95)	3.8 (1.7)

M23551

Fig. 9. VBN3 dimensions in inches (millimeters).

### Mounting Plate Adjustment

The Actuator Mounting Plate can be rotated to a different position for installation in confined spaces. This is accomplished as follows:

1. Remove the handle from the shaft and set it aside.
2. Remove the two screws that hold the stem assembly to the mounting plate and set them aside.
3. Remove and set aside the stem assembly.
4. Remove and set aside the two screws that attach the mounting plate to the valve.
5. Remove and set aside hold-down ring from mounting plate.
6. Rotate mounting plate around valve top to the desired position.

NOTE: Take note of the screw hole positions on the valve. They limit the mounting plate positions.

7. Lower ring down to valve body and engage it in the new position relative to the mounting plate.
8. Tighten screws to valve body securing the mounting plate.
9. Reattach the stem assembly to the mounting plate.
10. If desired, replace the handle on the shaft.

NOTE: See Fig. 19 for valve exploded view.

## Electrical Installation

1. If necessary, remove actuator wiring cover.
2. Wire actuator using Figures 10 through 18 for the application required.
3. Replace cover.

## Wiring

VALVES WITH NON-SPRING RETURN ACTUATORS (MN6105, MN7505)

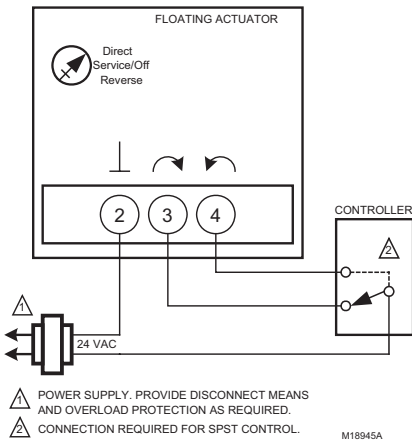

Fig. 10. Wiring for On/Off Control

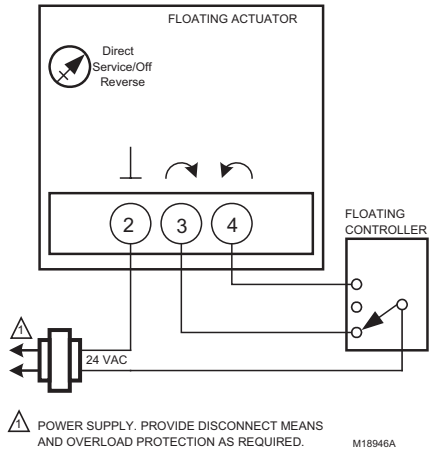

Fig. 11. Wiring for Floating Control

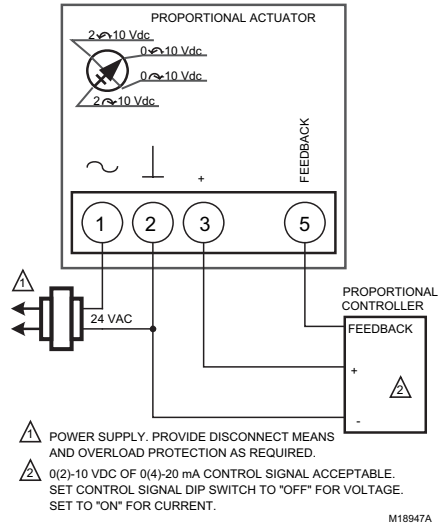

Fig. 12. Wiring for Modulating Control

VALVES WITH SPRING RETURN ACTUATORS (MS7505, MS8105)

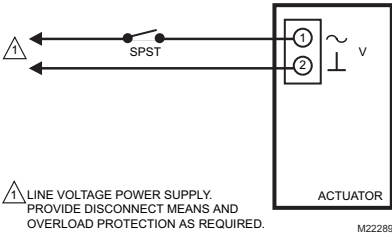
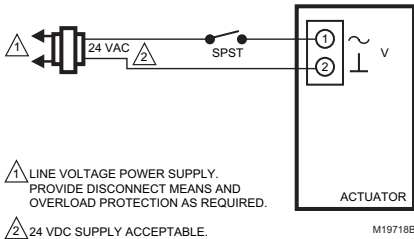

Fig. 13. Wiring for On/Off Control

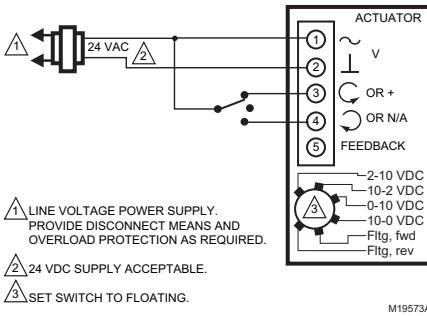

Fig. 14. Wiring for Floating Control (Floating mode setting)

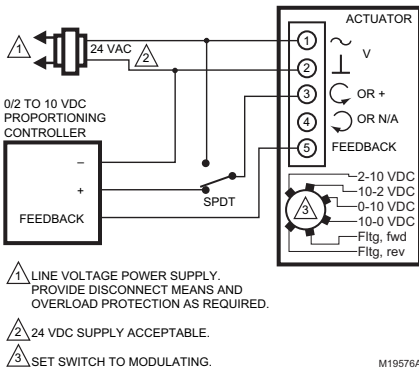

Fig. 15. Override to full open (Modulating mode setting)

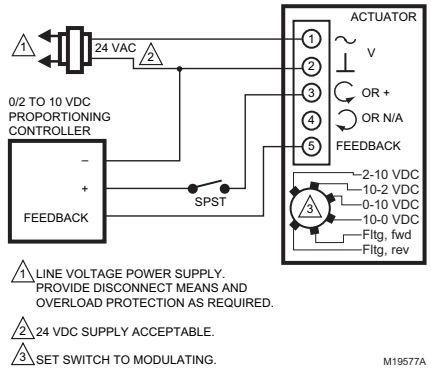

Fig. 16. Override to full closed (Modulating mode setting)

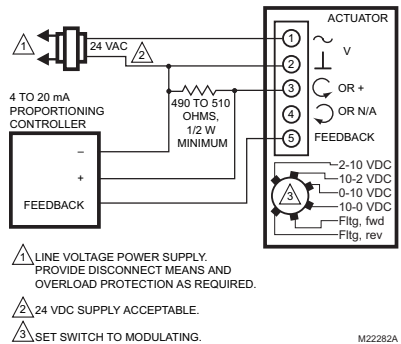
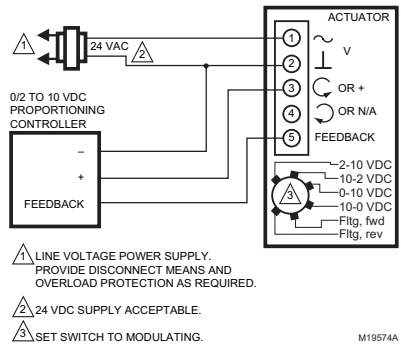
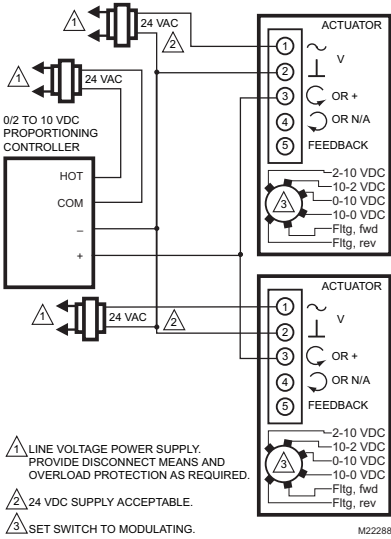
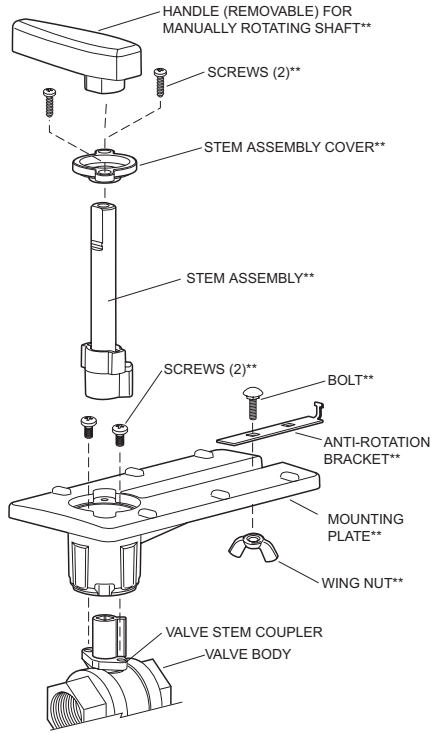

Fig. 17. Wiring for Proportioning Controllers (Modulating mode setting)



**Fig. 18. Wiring for Proportioning controllers operating multiple actuators (Modulating mode setting)**



\*\*INCLUDED IN REPLACEMENT KIT (PART NO. 5112-11)

M13738

**Fig. 19. Valve assembly exploded view.**

NOTE: All identified parts except for the valve body and aluminum valve stem coupler are included in Replacement Kit (part no. 5112-11)

## OPERATION AND CHECKOUT

Once both the mechanical and electrical installations are complete:

1. Cycle the actuator to verify that the direction of rotation suits the control sequence.
2. If the rotation direction is incorrect:
  - a. For 2-position control actuators: Remount actuator on the bracket.
  - b. For floating control actuators: Reverse two control signal wires (CW/CCW).
  - c. For analog control actuators either:
    - (1) Reposition reverse/direct acting switch, or
    - (2) Remount actuator on the bracket.
3. If the control scheme requires fail-safe operation, ensure that, upon removal of power, the fail position coincides with the control sequence.
4. If the fail safe position is incorrect, remove and reinstall the actuator in the opposite orientation as follows:
  - a. Loosen the shaft coupling bolt using a 10 mm wrench.
  - b. Loosen all other mounting bolts connecting the actuator to the mounting bracket, and set aside.
  - c. Remove the actuator from the valve shaft.
  - d. Move the actuator coupling to the opposite side of the actuator, as displayed in Figure 20.

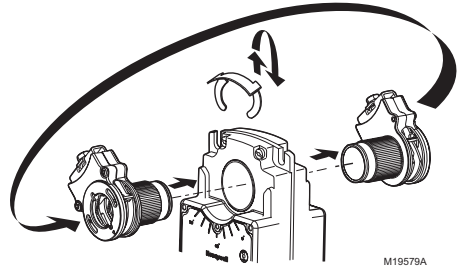

**Fig. 20. Mounting shaft coupling to actuator opposite side.**

- (1) Remove the retainer clip from the shaft coupling and set it aside for later use.
  - (2) Remove shaft coupling from one side of the actuator.
  - (3) Replace the shaft coupling on the opposite side of the actuator, aligning it based on the stroke labelling.
  - (4) Replace the retainer clip on the shaft coupling using the groove of the coupling.
- e. Reconnect the actuator to the valve mounting bracket by replacing the screws previously removed (step b)
  - f. Tighten the shaft coupling bolt using a 10 mm wrench.

For detailed actuator information, see Honeywell literature:

- 63-2607—MS7505/MS8105 Actuator Product Data
- 63-2632—MN6105/MN7505 Floating Actuator Product Data
- 63-2633—MN6105/MN7505 Modulating Actuator Product Data

### Automation and Control Solutions

Honeywell International Inc.  
1985 Douglas Drive North  
Golden Valley, MN 55422  
customer.honeywell.com

Honeywell Limited-Honeywell Limitée  
35 Dynamic Drive  
Toronto, Ontario M1V 4Z9

**Honeywell**

