

MOTOR MOUNTED (CLOSE COUPLED) PUMPS SHAFT SLEEVE AND SPACER REPLACEMENT | SERIES 4280, 4360D, 4380 & 4382 | INSTALLATION AND OPERATING INSTRUCTIONS

File No: 6042.25
Date: OCTOBER 05, 2015
Supersedes: 6042.25
Date: JAN. 16, 2015

SHAFT SLEEVE MAINTENANCE

Armstrong has two types of shaft sleeves in service: the old style shaft sleeve made of bronze or stainless steel which includes a spacer in the design, and the new style shaft sleeve made of stainless steel and does not have a spacer. The presence/absence of the spacer is the only visual way to differentiate between old and new style sleeves.

The old and new sleeves have different removal and installation procedures (outlined below). If it is not possible to determine which style sleeve you have, then please contact your local Armstrong rep to confirm. Whenever possible, please replace the old style sleeve with a new style shaft sleeve.

See separate instructions to remove the motor from, and replace the motor into, the pumping unit.

OLD STYLE SHAFT SLEEVE WITH SPACER

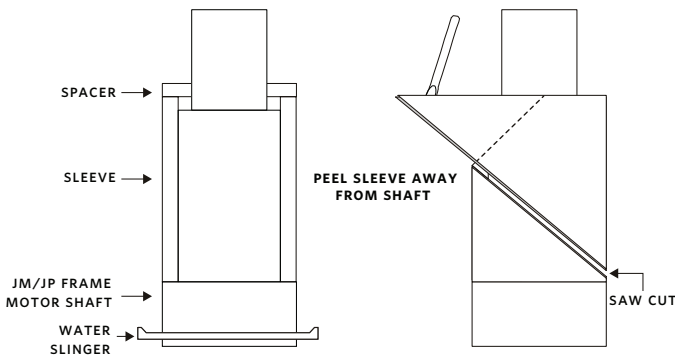

See separate instructions to remove the motor from, and replace the motor into, the pumping unit.

Sleeve and spacer replacement procedure

- 1 Remove the spacer and water slinger.
- 2 Remove the existing shaft sleeve. Do not heat or hammer sleeve off, or motor damage will occur. Cut the sleeve diagonally, with a hacksaw; a single cut the whole length of the sleeve. Ensure that the cut depth does not damage the shaft. Using a hammer and chisel, carefully peel back the sleeve section until the cut spiral is removed. If well cut, the sleeve removal is not difficult.

- 3 Stand the motor with the shaft upright. Support, if necessary for safety.
- 4 Support the shaft sleeve on a suitable metal bar, with insulated handle. (A large round file is ideal) The sleeve beveled end should be close to the motor. Heat the sleeve until dull red. Slide the sleeve, quickly and evenly, over the shaft (Beveled end first) and butt firmly against the motor shaft shoulder.
- 5 Wait until the sleeve cools and slide the water slinger over the shaft, close to the motor. Place the spacer on top of the sleeve.

The motor is now ready to be used on the pump.

NEW STYLE SHAFT SLEEVE WITHOUT SPACER

- 1 Remove water slinger.
- 2 Heat the shaft sleeve to 250°C to soften the glue and remove the sleeve. The parts will be hot so use appropriate gloves. Wipe off excess glue from motor shaft. If necessary, excess glue could be removed with very fine sandpaper and/or appropriate Loctite[®] solvent.
- 3 All the parts must be clean before assembling (see step 2) and appropriate primer (activator Loctite[®] 7649) is to be applied on entire surfaces being glued. The primer dries fast, however it has to be fully dry before the gluing compound application. The Loctite Activator also speeds up the curing time for the Loctite compound to be applied in the next step.
- 4 Apply the Loctite[®] 609™ compound to the shaft only and immediately slide the sleeve on it. Rotate the sleeve as it is being pushed on the shaft. To make sure that the glue fills entire engagement area, pull the sleeve up and down on the shaft while rotating and check if the shaft surface is wetted. Leave the assembly in vertical position with the sleeve positioned up. If the Loctite Activator[®] 7649 was used, the bond will cure after 5 minutes. If the activator was not used, then the shaft must be left to cure for 24 hours.
- 5 Re-install water slinger.

The motor is now ready to be used on the pump.

TORONTO

23 BERTRAND AVENUE
TORONTO, ONTARIO
CANADA
M1L 2P3
+1 416 755 2291

BUFFALO

93 EAST AVENUE
NORTH TONAWANDA, NEW YORK
U.S.A.
14120-6594
+1 716 693 8813

BIRMINGHAM

HEYWOOD WHARF, MUCKLOW HILL
HALESOWEN, WEST MIDLANDS
UNITED KINGDOM
B62 8DJ
+44 (0) 8444 145 145

MANCHESTER

WOLVERTON STREET
MANCHESTER
UNITED KINGDOM
M11 2ET
+44 (0) 8444 145 145

BANGALORE

#59, FIRST FLOOR, 3RD MAIN
MARGOSA ROAD, MALLESWARAM
BANGALORE, INDIA
560 003
+91 (0) 80 4906 3555

SHANGHAI

NO. 1619 HU HANG ROAD, XI DU TOWNSHIP
FENG XIAN DISTRICT, SHANGHAI
P.R.C.
201401
+86 21 3756 6696

**MAKING
ENERGY
MAKE
SENSE™**