

PRESSURE AND TEMPERATURE SENSORS for use with the BURNERLOGIX Burner Management System and PPC4000 Series Fuel/Air Ratio Controller

DESCRIPTION

The BLPS, TS350 and TS752 Series of pressure and temperature sensors are designed for use with the PPC4000 Fuel Air Ratio Controller and BurnerLogix Burner Management System with Integrated Boiler Control.

The pressure sensors (P/N BLPS-x) utilize a solid state pressure transducer to indicate steam pressure. The temperature sensors (P/N TS350-x and TS752-x) utilize a platinum, positive temperature coefficient sensing element to provide indication of water temperature, stack temperature, boiler water temperature of a steam boiler, and outdoor air temperature. The pressure sensors have a maximum overpressure specification of 200% Full Scale Output and 800% Burst. The pressure sensors are equipped with a 1/4" NPT male fitting. The Immersion Style Temperature Sensors have a 1/2" NPT mounting for the 2", 4" and 8" thermowell probe.

The pressure and temperature sensors provide a 4-20 mA control signal over their respective stated ranges to the PPC4000 and BurnerLogix Control systems. No setting or calibration is required for either type of sensor.

The PPC4000 and BurnerLogix Control systems perform continuous safety checks on the operation of all pressure and temperature sensors to insure their safe and proper operation (e.g. under range, over range, open wiring, etc.).



WARNING: The PPC4000 Fuel Air ratio Controller and BurnerLogix Control System must only be used with the approved pressure and temperature sensors. (e.g.: BLPS-15, TS350-4, etc.). Do not use with any other types of pressure or temperature sensors. UL approval requires these sensors.



Fireye P/N	Description
BLPS-15	Pressure transducer, 0 to 15 psi (0 to 1030 mb), 4-20 mA output linear with pressure. 1/4" NPT mounting. Screw terminal connections and conduit adapter cover.
BLPS-25	Pressure transducer, -14.7 to 25 psi (-1013 to 1720 mb), 4-20 mA output linear with pressure. 1/4" NPT mounting. Screw terminal connections and conduit adapter cover.
BLPS-30	Pressure transducer, 0 to 30 psi (0 to 2070 mb), 4-20 mA output linear with pressure. 1/4" NPT mounting. Screw terminal connections and conduit adapter cover.
BLPS-200	Pressure transducer, 0 to 200 psi (0 to 13.8 Bar), 4-20 mA output linear with pressure. 1/4" NPT mounting. Screw terminal connections and conduit adapter cover.
BLPS-300	Pressure transducer, 0 to 300 psi (0 to 20.7 Bar), 4-20 mA output linear with pressure. 1/4" NPT mounting. Screw terminal connections and conduit adapter cover.
TS350-2	Temperature sensor, Range 32°F to 350°F (0°C to 176°C), 4-20 mA output, linear with temperature. Insertion length is 2 inches. Stainless steel thermowell included with 1/2"-14 NPT mounting.
TS350-4	Temperature sensor, Range 32°F to 350°F (0°C to 176°C), 4-20 mA output, linear with temperature. Insertion length is 4 inches. Stainless steel thermowell included with 1/2"-14 NPT mounting.
TS350-8	Temperature sensor, Range 32°F to 350°F (0°C to 176°C), 4-20 mA output, linear with temperature. Insertion length is 8 inches. Stainless steel thermowell included with 1/2"-14 NPT mounting.
TS752-2	Temperature sensor, Range 32°F to 752°F (0°C to 176°C), 4-20 mA output, linear with temperature. Insertion length is 2 inches. Stainless steel thermowell included with 1/2"-14 NPT mounting.
TS752-4	Temperature sensor, Range 32°F to 752°F (0°C to 176°C), 4-20 mA output, linear with temperature. Insertion length is 4 inches. Stainless steel thermowell included with 1/2"-14 NPT mounting.
TS752-8	Temperature sensor, Range 32°F to 752°F (0°C to 176°C), 4-20 mA output, linear with temperature. Insertion length is 8 inches. Stainless steel thermowell included with 1/2"-14 NPT mounting.

Note: BLPS-25 is not compatible with the Burnerlogix Control System

GENERAL SPECIFICATIONS

Temperature Sensors:

Temperature Measurement Range:

TS350-X: 32°F to 350°F (0°C to 176°C)

TS752-X: 32°F to 752°F (0°C to 400°C)

RTD Type:

Platinum, 100 ohms +0.1% @32°F (0°C)

Temperature Coefficient: .00385 ohms/ohms/C

Output: 4-20 mA, linear with temperature

Operating Temperature Range: -13°F to 185°F (-25°C to 85°C)

Accuracy: +/- 0.75% of span

Thermowell Case: 300 Series stainless steel

Mechanical Fittings: 1/2-14 NPT

Pressure Sensors:

Pressure Measurement Range: 0 to 15, -14.7 to 25, 0 to 30, 0 to 200, 0 to 300 psig

Excitation Voltage: 9-30Vdc (supplied by BurnerLogix control)

Accuracy: +/- 0.25% Full Scale (at constant temperature)

Output: 4-20 mA, linear with pressure

Maximum Over Pressure: 200% of full scale

Maximum Burst Pressure: 800% of full scale

Operating Temperature Range: -40°F to 185°F (-40°C to 85°C)

Fitting: 1/4" NPT Male

Electrical: 1/2" Conduit and Terminal Strip

APPROVALS

Underwriters Laboratories Inc.:

- MCCZ File MP1537
- Controls, Primary Safety - Listed
- MCCZ2 File MP1537
- Controls, Primary Safety - Component
- MCCZ7 File MP1537
- Controls, Primary Safety Certified for Canada
- MCCZ8 File MP1537
- Controls, Primary Safety Certified for Canada - Component

Factory Mutual:

FM Class 7610

Acceptable by:

Industrial Risk Insurers (I.R.I.)

FIGURE 1. Pressure Sensor - BLPS-15, -25, -30, -200, -300

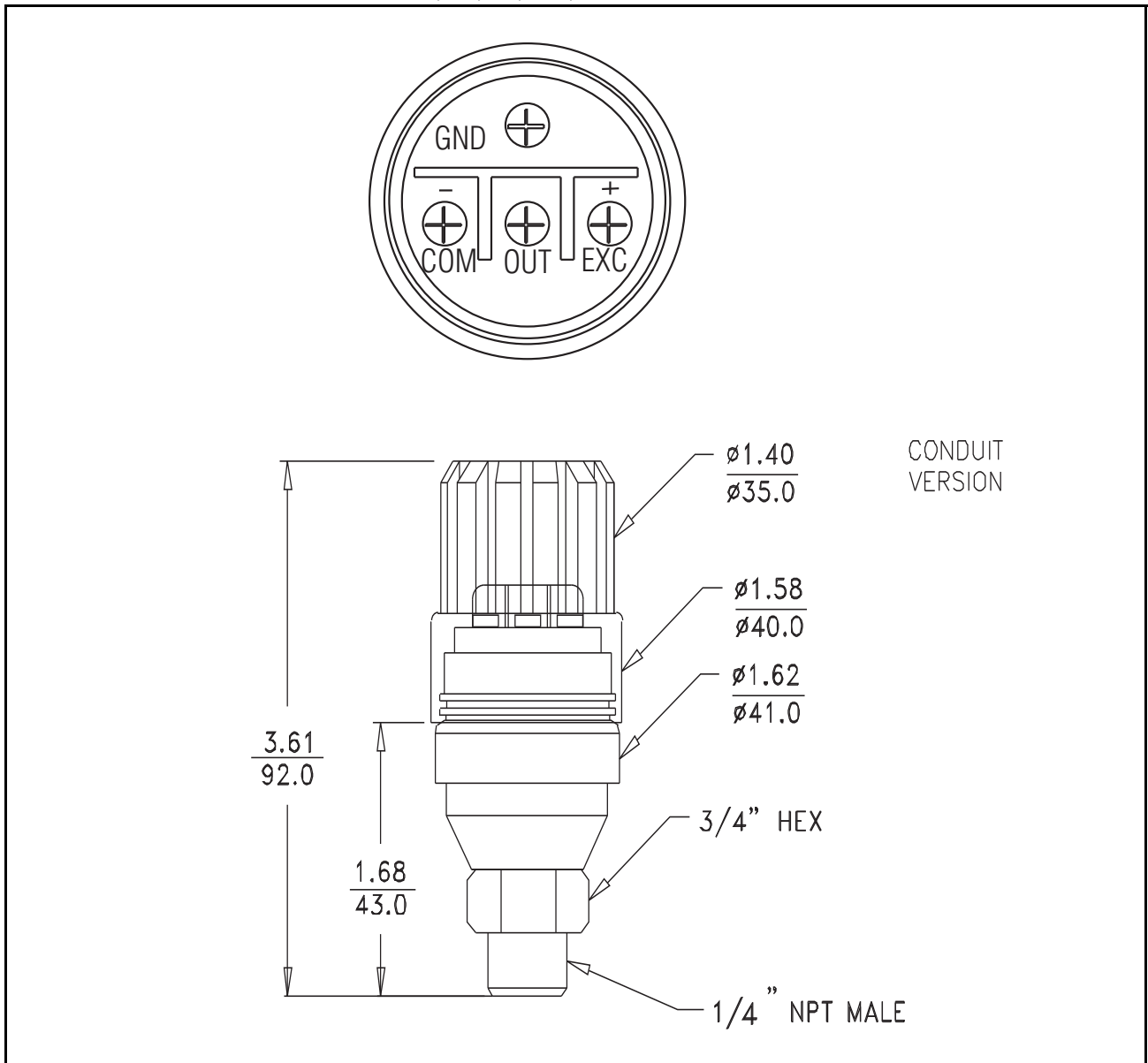

FIGURE 2. Temperature Sensor - TS350-2, TS350-4, TS350-8

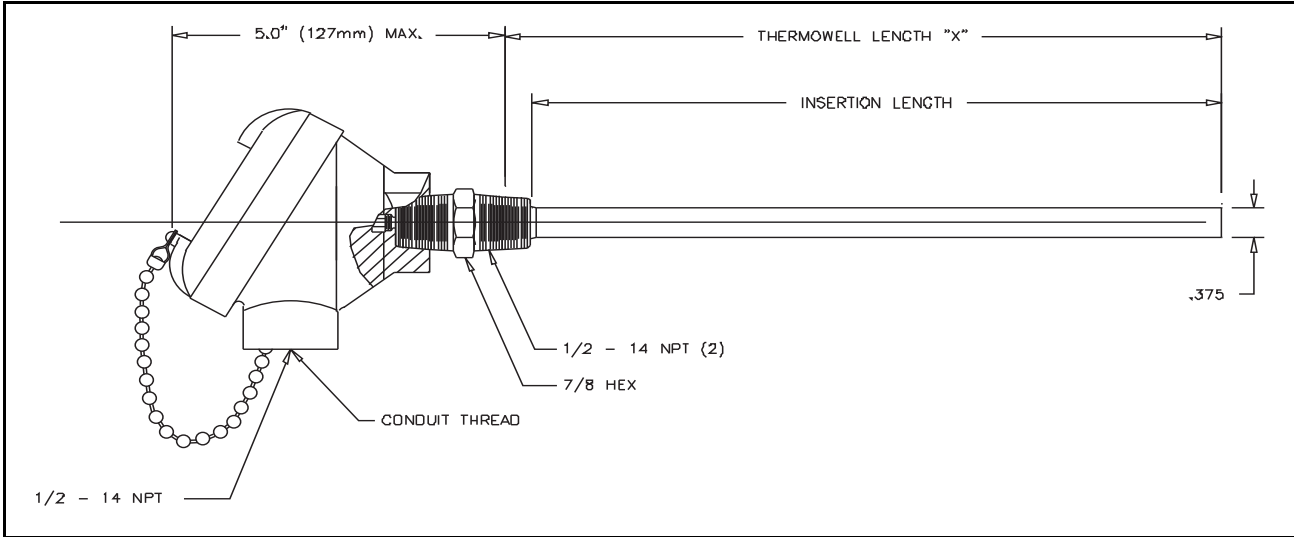
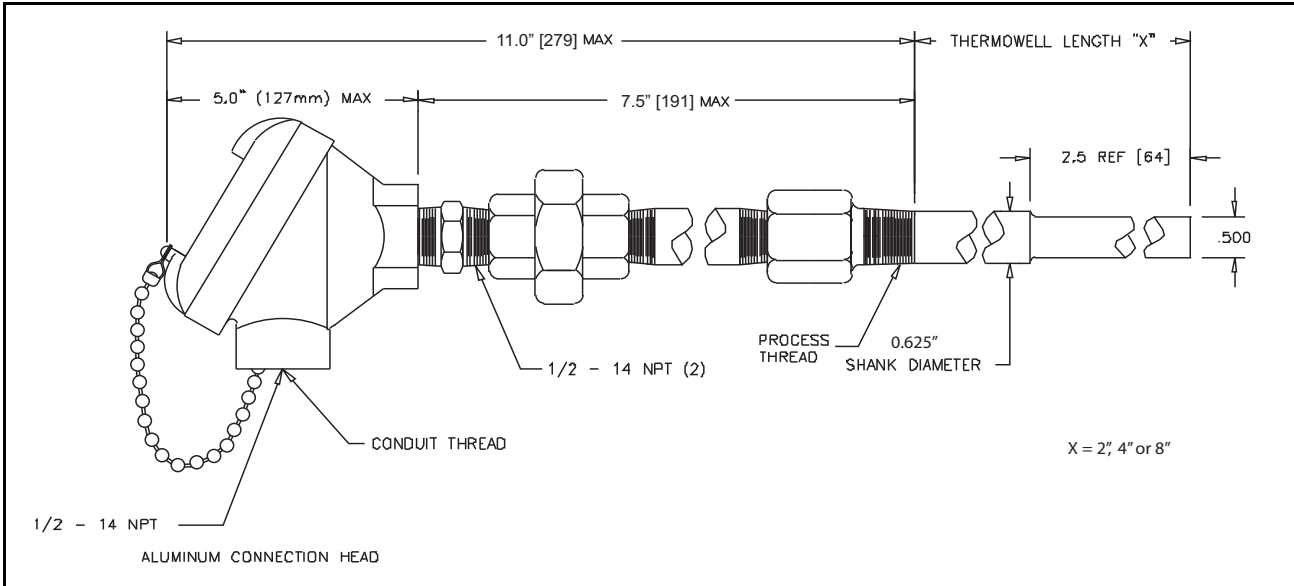

FIGURE 3. Temperature Sensor - TS752-2, TS752-4, TS752-8



WARNING:

1. Read these instructions carefully. Failure to follow them could result in a hazardous or dangerous condition.
2. Insure that the range of the selected sensor is appropriate for the application. Note: A general rule to follow when selecting the sensor range is that the expected value of the monitored pressure or sensor should fall between 40-70% of the upper range of the sensor. For example, a steam boiler maintains 20 lbs. pressure, select the BLPS-30 Pressure Sensor, with a 0-30 PSIG range
3. The sensors must be located where the ambient temperature will not exceed the maximum ambient operating temperature specified for the sensor.
4. Insure that the pressure range programmed on the BurnerLogix Boiler Room Control matches the installed pressure sensor. Refer to Bulletin BLZ-1001.
5. Do not mount any of the sensors where they could be used as a footstep.
6. Installation must be performed by a trained, experienced flame safeguard technician.



WARNING: The electro-mechanical high steam limit and/or high hot water temperature limit MUST REMAIN in the running interlock circuit of the flame safeguard control.

MOUNTING PRESSURE SENSORS

Note: Refer to Figure 4.

1. The steam pressure sensors (BLPS-15, -25, -30, -200, -300) provide a 1/4" NPT male fitting for connection to the steam header. Included is a 1/4" coupling.
2. Make sure the boiler is shut down and zero steam pressure exists in the boiler vessel.
3. Disconnect power to the boiler controller so the boiler cannot sequence during installation of the steam pressure sensor.
4. Always mount the steam pressure sensor *above the water line* of the boiler.
5. Locate the pressure sensors where the ambient temperature will not exceed 185F

FIGURE 4.

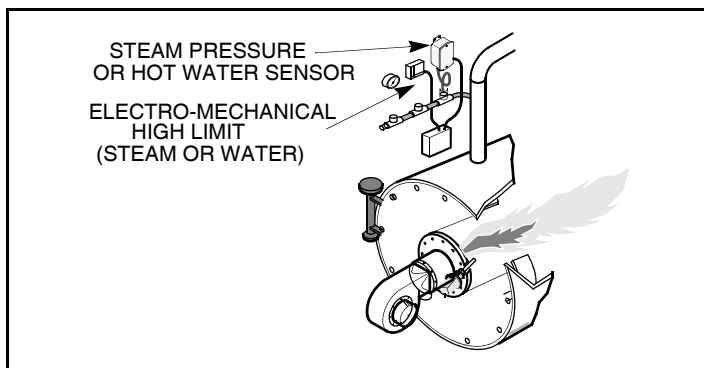

6. Although the unit can withstand substantial vibration without damage or significant output effects, it is good practice to mount the pressure sensor where there is minimum vibration.
7. A steam trap (siphon loop) *must be connected* between the boiler and the pressure sensor to prevent boiler scale and corrosive vapors from affecting the pressure sensor element.
8. Use only a small amount of pipe compound to seal the connection joints. Excess pipe compound may clog the fitting and prevent proper operation of the sensor.
9. Make all pipe connections in accordance with approved standards.
10. When tightening the sensor, apply a wrench to the hex flats located just above the pressure fitting. **DO NOT** tighten by using a pipe wrench on the housing. Do not tighten the pressure sensor by hand.

MOUNTING TEMPERATURE SENSORS

The immersion style temperature sensors have a 1/2" NPT mounting for the 2", 4" and 8" thermowell probes, and a 1/2" conduit fitting.

HOT WATER

Note: Refer to Figure 4

1. Disconnect power to the boiler controller so the boiler cannot sequence during installation of the hot water temperature sensor.
2. The thermowell must be mounted where it is always exposed to the circulation of the hot water
3. If the water system is full, drain the system below the point where the thermowell will be installed.
4. Tap an appropriate size fitting. (2", 4" and 8" thermowell have 1/2"NPT fitting).
5. Insert the appropriate thermowell (2", 4", or 8") and tighten.
6. Fill the system to check for leakage.



LEAD/LAG OPERATION: When two hot water boilers are set-up for lead/lag operation, a hot water temperature sensor must be installed for each boiler.

STANDBY WATER TEMPERATURE

1. Disconnect power to the boiler controller so the boiler cannot sequence during installation of the standby temperature sensor.



WARNING: Location of the temperature sensor to monitor boiler water temperature of a steam boiler is critical. The sensor should be mounted where it is always exposed to the circulation of the boiler water, not too close to a hot or cold inlet or steam coil. Consult the boiler manufacturer for guidance on the sensor location.

2. The thermowell must be mounted where it is always exposed to the circulation of the hot water.
3. If the water system is full, drain the system below the point where the thermowell will be installed.
4. Tap an appropriate size fitting (2", 4" and 8" thermowells have 1/2" NPT fitting).
5. Insert the appropriate thermowell (2", 4", or 8") and tighten.

STACK TEMPERATURE

1. Use the existing well connection for the stack temperature sensor if provided by the boiler manufacturer.
2. If no well connection is provided, select an appropriate location for mounting the temperature sensor. Preferably as close to the boiler outlet as possible.

OUTDOOR AIR TEMPERATURE

1. The outdoor air temperature sensor should be mounted on the outside of the building where it will be exposed to representative air temperature, but not to direct sunlight. A sun shield may be required.
2. Mount the temperature sensor high enough so it cannot be covered with snow, leaves, or other debris, or be tampered with. Vents from the building should be avoided.

WIRING SENSORS



CAUTION: Disconnect power supply from the BurnerLogix Control before connecting wires to prevent electrical shock and equipment damage.

PRESSURE SENSORS

1. All wiring must be in accordance with National Electrical Code and local codes, ordinances, and regulations.
2. Sensor housing provides connection for 1/2" conduit.
3. The pressure sensors require 2 conductor, 18 gauge, shielded cable. Power limited, rated for 300V @ 105C. Use Belden 9318 or equivalent.

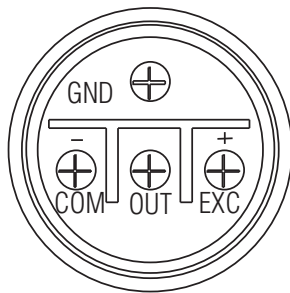

For 4-20 mA output,
use + EXC and - COM terminals

4. The shield should be connected to the earth ground terminal on the wiring base of the Burner-Logix Control (Terminal #E) or to the common ground established in the cabinet. The shield should be taped at the sensor to avoid unintended contact with the sensor housing.
5. All sensor wiring should be in a separate conduit. DO NOT install sensor wiring in any conduit or junction boxes with high voltage wiring.
6. Maximum wiring distance for sensor wiring is 100 feet.
7. See Table 1 for wiring terminations to the Burnerlogix
8. See Table 2 for wiring connections to the PPC4000.

TEMPERATURE SENSORS

1. All wiring must be in accordance with National Electrical Code and local codes, ordinances, and regulations.
2. Sensor housing provides connection for 1/2" conduit.

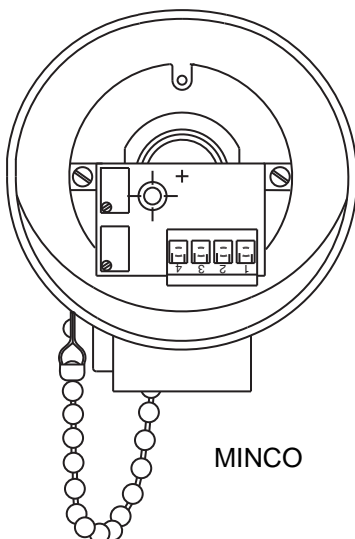

For 4-20 mA output,
use terminals 1 (+) and 2 (-)

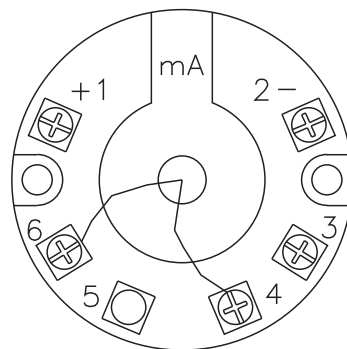

MEASUREMENT SPECIALTIES

For 4-20 mA output,
use terminals (+) and (-)

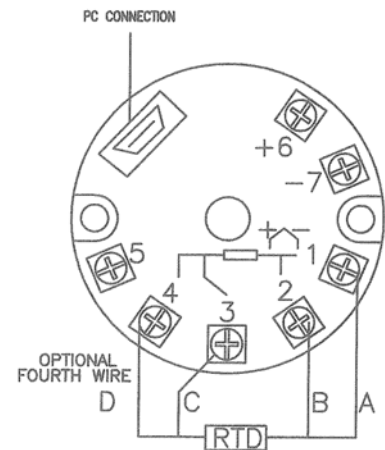

Temperature Specialists Inc.

For 4-20 mA output,
use terminals 6 and 7



3. The temperature sensors require 2 conductor, 18 gauge, shielded cable. Power limited, rated for 300V @ 105C. Use Belden 9318 or equivalent.
4. The shield should be connected to the earth ground terminal on the wiring base of the BurnerLogix Control (Terminal #E) or to the common ground established in the cabinet. The shield should be taped at the sensor to avoid unintended contact with the sensor housing.
5. All sensor wiring should be in a separate conduit. DO NOT install sensor wiring in any conduit or junction boxes with high voltage wiring.
6. Maximum wiring distance for sensor wiring is 100 feet.
7. See Table 1 and 2 for wiring terminations.

Table 1: Burnerlogix wiring connections

TS350/TS752			BLPS	PCV	AUX1	AUX2
Minco	Meas Sp	Temp Sp		BurnerLogix Terminals		
1+	1+	6+	+ EXC	X (WHT/BLU)	X (WHT/BLU)	X (WHT/BLU)
2-	2-	7-	- COM	11 (WHT/GRN)	22 (WHT/VIO)	23 (BRN/WHT)

Table 2: PPC4000 wiring connections

TS350/TS752			BLPS	PCV	AUX1	AUX2	SENS4	SENS5
Minco	Meas Sp	Temp Sp		PPC4000 Terminals				
1+	1+	6+	+ EXC	P11.2	P11.2	P11.3	P11.3	P11.3
2-	2-	7-	- COM	P11.10	P11.9	P11.8	P11.7	P11.6

CAUTION: PROGRAM AND SET-UP



The proper operation of the BurnerLogix System and the pressure and temperature sensors requires that the selected pressure ranges are appropriate for the application and must match the pressure range programmed on the BurnerLogix Control. Insure that the range of the selected sensor is correct for the application and the pressure range programmed on the BurnerLogix Integrated Flame Safeguard and Boiler Controller matches the installed pressure sensor. Refer to Bulletin BLZ-1001.

NOTICE

When Fireeye products are combined with equipment manufactured by others and/or integrated into systems designed or manufactured by others, the Fireeye warranty, as stated in its General Terms and Conditions of Sale, pertains only to the Fireeye products and not to any other equipment or to the combined system or its overall performance.

WARRANTIES

FIREYE guarantees for *one year from the date of installation or 18 months from date of manufacture* of its products to replace, or, at its option, to repair any product or part thereof (except lamps and photocells) which is found defective in material or workmanship or which otherwise fails to conform to the description of the product on the face of its sales order. **THE FOREGOING IS IN LIEU OF ALL OTHER WARRANTIES AND FIREYE MAKES NO WARRANTY OF MERCHANTABILITY OR ANY OTHER WARRANTY, EXPRESS OR IMPLIED.** Except as specifically stated in these general terms and conditions of sale, remedies with respect to any product or part number manufactured or sold by Fireeye shall be limited exclusively to the right to replacement or repair as above provided. In no event shall Fireeye be liable for consequential or special damages of any nature that may arise in connection with such product or part.



FIREYE®
 3 Manchester Road
 Derry, New Hampshire 03038 USA
 www.fireeye.com

BLZPTS-1
 NOVEMBER 19, 2013
 Supersedes November 6, 2013