



CWE2



NOTICE

- This product is not intended for life or safety applications.
- Do not install this product in hazardous or classified locations.
- Read and understand the instructions before installing this product.
- Turn off all power supplying equipment before working on it.
- The installer is responsible for conformance to all applicable codes.

If this product is used in a manner not specified by the manufacturer, the protection provided by the product may be impaired. No responsibility is assumed by the manufacturer for any consequences arising out of the use of this material.

CWE2 Series

Economy Wall Mounted Air Quality Sensors

Product Overview

The CWE2 Series of air quality sensors for living space are for use with BAS controllers designed to accept 4 to 20mA, 0 to 5 Vdc or 0 to 10 Vdc outputs. These sensors measure CO₂ levels using a dual-beam, non-dispersive infrared (NDIR) technology.

The CWE2 Series Economy sensor has an accuracy of $\pm 30 \text{ ppm} \pm 3\%$ of measured value, features 2-wire 4 to 20mA and 3-wire voltage outputs, and is available with optional temperature output.

Product Identification

User Interface



- Blank = None
- C = 1000 PT RTD
- D = 10K T2 thermistor
- H = 10K T3 thermistor
- K = 10K curve G/11K shunt
- M = 20K NTC thermistor
- N = 1.8K TAC thermistor

Specifications

OPERATING ENVIRONMENT	
Input Power	Class 2; 20 to 30 Vdc, 24 Vac, 50 to 60 Hz
Max. Current	20 mA
Analog Output	Selectable 4 to 20 mA, 0 to 5 V, 0 to 10 V
Operating Temp. Range	0 to 50 °C (32 to 122 °F)
Operating Humidity Range	0 to 95% RH non-condensing
Housing Material	High-impact ABS plastic
Terminal Block Torque	0.5 to 0.6 N-m (0.37 to 0.44 in-lbf)
CO ₂ TRANSMITTER	
Sensor Type	Dual-beam, non-dispersive infrared (NDIR), diffusion sampling
Output Range	0 to 2000 ppm
Accuracy	$\pm 30 \text{ ppm} \pm 3\%$ of measured value
Repeatability	$\pm 20 \text{ ppm} \pm 1\%$ of measured value
Startup Time	≤ 20 seconds
Response Time	≤ 75 seconds for 90 degree step change
Max. Load Resistance*	100 Ω at 20 Vdc 250 Ω at 24 Vdc 500 Ω at 30 Vdc
WIRING TERMINALS	
Terminal Blocks	Screw terminals, 18-24 AWG
Screw Terminal Torque	0.2 N-m (2.0 in-lbf) max.

Specifications (cont.)

WARRANTY	
Limited Warranty	3 years
COMPLIANCE INFORMATION	
Agency Approvals	UL 916, European conformance CE: EN61000-6-2 EN61000-6-3 EN61000 Series - industrial immunity EN 61326-1 FCC Part 15 Class B, REACH, RoHS, RCM (Australia), ICES-003 (Canada)

* Applicable for CWE2 4-20 mA current mode only. If load parameters are not met, product will reset.

Dimensions

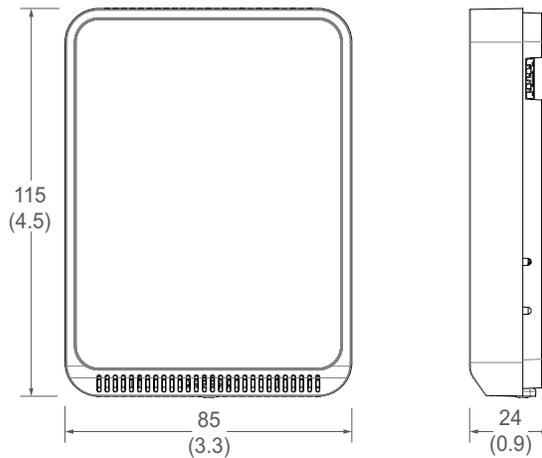

Functions

The CWE2 Series sensor measures CO₂ and temperature (if equipped) in a room and provides analog outputs to a controller.

Installation

1. Remove the cover from the base at the bottom of the device.



2. Position the sensor base vertically on the wall 1.35 m (4.5 ft.) above the floor with the "UP" arrow facing upward. Locate away from windows, vents and other sources of draft. If possible, do not mount on an external wall, as this may cause inaccurate temperature readings.



Installation (cont.)

3. Pull 18 or 22 AWG cable(s) through the hole in the backplate.



4. Mount the backplate onto the wall using the screws provided.

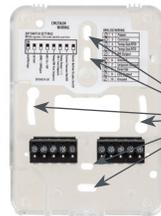

Six screw holes available. Use a minimum of two for secure mounting.

Connect the wires to the screw terminals. Do not over-tighten the screws.



CWE2 voltage output wiring diagram:

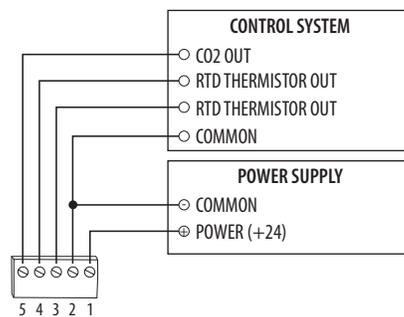

CWE2 current output wiring diagram:

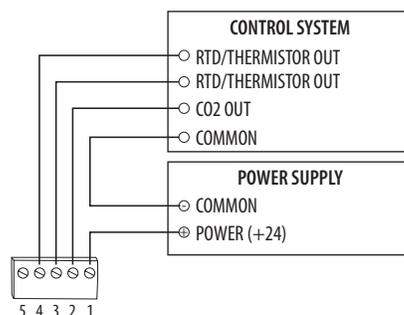

Installation (cont.)

5. Set the DIP switches.

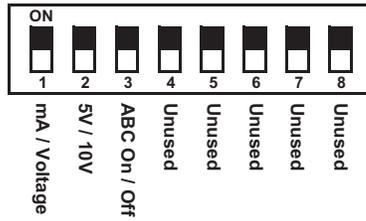

Switch	Function	Description
1	Output mode	ON - 4-20mA output mode enabled OFF - Voltage output mode enabled
2	Voltage output range*	ON - 0-5V output range enabled OFF 0-10V output range enabled
3	Automatic Baseline Calibration (ABC) for CO ₂	ON - ABC enabled OFF - ABC disabled
4	Unused	Unused
5	Unused	Unused
6	Unused	Unused
7	Unused	Unused
8	Unused	Unused

* Only used with voltage output mode enabled.

6. With sensor base fully installed, align top of cover to mounting tabs on top of sensor base. Swing cover downward until it latches at the bottom.



7. Install locking screw to secure cover in closed position.



China RoHS Compliance Information

Environment-Friendly Use Period (EFUP) Table

部件名称	有害物质 - Hazardous Substances					
Part Name	铅 (Pb)	汞 (Hg)	镉 (Cd)	六价铬 (Cr (VI))	多溴联苯 (PBB)	多溴二苯醚 (PBDE)
电子件 Electronic	X	O	O	O	O	O

本表格依据SJ/T11364的规定编制。

O: 表示该有害物质在该部件所有均质材料中的含量均在GB/T 26572规定的限量要求以下。

X: 表示该有害物质至少在该部件的某一均质材料中的含量超出GB/T 26572规定的限量要求。
(企业可在此处, 根据实际情况对上表中打“X”的技术原因进行进一步说明。)

This table is made according to SJ/T 11364.

O: indicates that the concentration of hazardous substance in all of the homogeneous materials for this part is below the limit as stipulated in GB/T 26572.

X: indicates that concentration of hazardous substance in at least one of the homogeneous materials used for this part is above the limit as stipulated in GB/T 26572

Z000057-0B