

## E5XXXA SERIES

Cost-Saving, Versatile Monitoring  
Solution with Associated E683x Rope Style CTs  
(Sold Separately)



The E5xxxA Series DIN Rail Meter combines exceptional metering performance with a built-in integrator and power supply to deliver a cost-effective, easily installed solution for power monitoring applications. Multiple communication protocol options offer added flexibility for easy system integration.

E5xxxA devices work exclusively with Veris E683x Series rope CTs for fast connection. The rope style CTs allow convenient installation in tight spaces.

The data logging capability (E5xC3A and E5xx5A) protects data in the event of a power or communications failure elsewhere in the system. Different devices in the series offer serial communication, pulse output, and phase alarms to suit a wide variety of applications.

### SPECIFICATIONS

#### ACCURACY

Real Power & Energy  
E5xxxA 0.5% (ANSI C12.20, IEC 62053-22 Class 0.5S)

#### INPUTS

Control Power, AC 50/60 Hz; 5 VA max.; 90 V min.; UL Maximums:  
600 V<sub>L-L</sub> (347 V<sub>L-N</sub>); CE Maximum: 300 V<sub>L-N</sub>

Control Power, DC 3 W max.; UL and CE: 125 to 300 Vdc (external DC  
current limiting required)

Voltage Input UL: 90 V<sub>L-N</sub> to 600 V<sub>L-L</sub>; CE: 90 V<sub>L-N</sub> to 300 V<sub>L-N</sub>

Current Input 50 to 5000 A  
Scaling E683x Series rope style CTs only (CTs must be rated for  
connection to Class 1 voltage inputs)

Pulse Inputs (E5xHxA & E50FxA only)  
Contact inputs to pulse accumulators (one set with  
E5xH2A & E50F2A; two sets with E5xH5A & E51F5A)\*

#### OUTPUTS

All Models (except E5xHxA & E50FxA)  
Real Energy Pulse: N.O. static\*\*;  
Alarm contacts: N.C. static\*\*

E50BxA Reactive energy pulse\*\*

E5xCxA RS-485 2-wire Modbus RTU (1200 baud to 38.4 kbaud)

## Faster installation 0.5% accuracy

Integrator and power supply for the CTs are built into the meter... fewer devices to purchase and faster installation

ANSI C12.20 0.5% accuracy, IEC 62053-22 Class 0.5S on all E5xxxA...great for cost allocation

## Rope CTs

Versatile rope CTs allow convenient installation in tight spaces

## Easy installation

DIN rail or screw mounting options

## 400 to 5000A

Designed to work exclusively with E683x Series rope CTs which offer 1% accuracy from 50 to 5000 A... monitor a wide range of loads with breakers from 400 to 5000 A

## Multiple applications

Real energy output and phase loss alarm output on E50BxA and E5xCxA models...one device serves multiple applications

### APPLICATIONS

- Energy monitoring in building automation systems
- Commercial sub-metering
- Renewable energy
- Industrial monitoring
- Energy management
- Cost allocation

E5xHxA	RS-485 2-wire BACnet MS/TP (9600 baud to 115.2 kbaud)
--------	---

E50FxA	2-wire LON FT
--------	---------------

#### MECHANICAL

Mounting	DIN rail or 3-point screw mount
----------	---------------------------------

#### ENVIRONMENTAL

Operating Temp Range	-30 to 70 °C (-22 to 158 °F)
----------------------	------------------------------

Storage Temp Range	-40 to 85 °C (-40 to 185 °F)
--------------------	------------------------------

Humidity Range	<95% RH non-condensing
----------------	------------------------

Mounting Location	Not suitable for wet locations. For indoor use only.
-------------------	--

#### WARRANTY

Limited Warranty	5 years
------------------	---------

#### AGENCY APPROVALS

Agency Approvals	UL 508, IEC/EN 61010-1, California CSI Solar, ANSI C12.20
------------------	---



\*10 kV Vac/dc to 4 to 10 Vdc.

\*\*30 Vac/dc, 100 mA max.



**ORDERING INFORMATION**

	E50B1A	E50C2A	E50C3A	E50F2A	E50F5A	E50H2A	E50H5A	E51C2A	E51C3A	E51H2A	E51H5A		
<b>MEASUREMENT CAPABILITY - FULL DATA SET</b>													
Bi-directional Energy Measurements										•	•	•	•
Power (3-phase total and per phase): Real (kW) Reactive (kVAR), & Apparent (kVA)	•	•	•	•	•	•	•	•	•	•	•	•	•
Power Factor: 3-phase average & per phase	•	•	•	•	•	•	•	•	•	•	•	•	•
Present Power Demand: Real (kW), Reactive (kVAR), and Apparent (kVA)	•	•	•	•	•	•	•	•	•	•	•	•	•
Import & Export totals of Present Power Demand: Real (kW), Reactive (kVAR), & Apparent (kVA)										•	•	•	•
Peak Power Demand: Real (kW), Reactive (kVAR), and Apparent (kVA)	•	•	•	•	•	•	•	•	•	•	•	•	•
Current (3-phase average and per phase)	•	•	•	•	•	•	•	•	•	•	•	•	•
Voltage: Line-Line and Line-Neutral (3-phase average and per phase)	•	•	•	•	•	•	•	•	•	•	•	•	•
Frequency	•	•	•	•	•	•	•	•	•	•	•	•	•
ANSI C12.20 0.5% accuracy, IEC 62053-22 Class 0.5S	•	•	•	•	•	•	•	•	•	•	•	•	•
Accumulated Net Energy: Real (kWh), Reactive (kVARh), and Apparent (kVAh)	•	•	•	•	•	•	•	•	•	•	•	•	•
Accumulated Real Energy by phase (kWh)	•	•	•	•	•	•	•	•	•	•	•	•	•
Import and Export Accumulators of Real and Apparent Energy										•	•	•	•
Reactive Energy Accumulators by Quadrant (3-phase total and per phase)										•	•	•	•
Demand Interval Configuration: Fixed or Rolling Block	•	•	•	•	•	•	•	•	•	•	•	•	•
Demand Interval Configuration: External Sync to Comms	•	•	•	•	•	•	•	•	•	•	•	•	•
<b>DATA LOGGING</b>													
Data Logging: 10 16-Bit Configurable (can include Date/Time) Data Buffers			•									•	
Data Logging: 3 Timestamped 32-Bit Configurable Data Buffers						•							•
Store up to 60 days of readings at 15-minute intervals				•		•						•	•
<b>OUTPUTS</b>													
Alarm Output (N.C.)	•	•	•	•		•				•	•	•	•
1 Pulse Output (N.O.)		•	•							•	•		
2 Pulse Outputs (N.O.)	•												
RS-485 Serial (Modbus RTU Protocol)		•	•							•	•		
RS-485 Serial (BACnet MS/TP Protocol)						•	•				•	•	
LON FT Serial (LonTalk Protocol)				•	•								
<b>INPUTS</b>													
2 Pulse Contact Accumulator Inputs					•		•						•
1 Pulse Contact Accumulator Input				•		•						•	

**REQUIRED CTS**

MODEL	DESCRIPTION
E683C502	Rogowski CT, 250 mm (9"), 600 V, 5 kA
E683D502	Rogowski CT, 300 mm (12"), 600 V, 5 kA
E683G502	Rogowski CT, 460 mm (18"), 600 V, 5 kA
E683J502	Rogowski CT, 600 mm (24"), 600 V, 5 kA
E683L502	Rogowski CT, 900 mm (35"), 600 V, 5 kA

**DIMENSIONAL DRAWING**

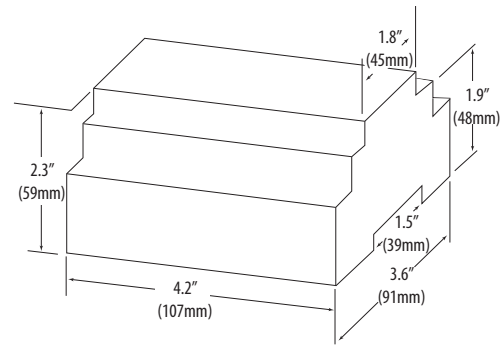

**DIN MOUNT CONFIGURATION**

Mounting Diagram

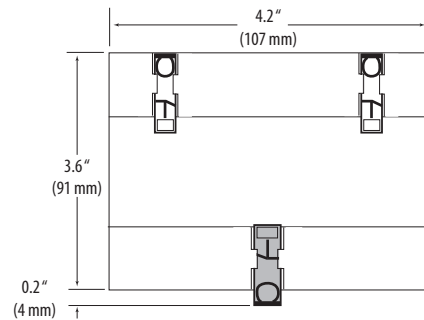

**SCREW MOUNT CONFIGURATION**

Mounting Diagram

