

BALDOR • RELIANCE

Customer information packet

EM3311T-8

7.5HP, 1770RPM, 3PH, 60HZ, 213T, 3734M, OPSB, F

Class - None

Division - Not Applicable

Specifications

Enclosure	OPSB
Frame	213T
Frame Material	Steel
Frequency	60.00 Hz
Haz Area Class and Group	None
Haz Area Division	Not Applicable
Motor Letter Type	Three Phase
Output @ Frequency	7.500 HP @ 60 HZ
Phase	3
Synchronous Speed @ Frequency	1800 RPM @ 60 HZ
Voltage @ Frequency	200.0 V @ 60 HZ
Agency Approvals	CURUSEEV NEMA PREMIUM NEMA_PREMIUM UR CSA EEV
Ambient Temperature	40 °C
Auxillary Box	No Auxillary Box
Auxillary Box Lead Termination	None
Base Indicator	Rigid
Bearing Grease Type	Polyrex EM (-20F +300F)
Blower	None
Current @ Voltage	23.300 A @ 200.0 V
Design Code	A
Drip Cover	No Drip Cover
Duty Rating	CONT
Efficiency @ 100% Load	91.0 %
Electrically Isolated Bearing	Not Electrically Isolated
Feedback Device	NO FEEDBACK
Front Face Code	Standard
Front Shaft Indicator	None
Heater Indicator	No Heater

Part detail

Revision	L
Type	AC
Mech. spec.	37F614
Base	
Status	PRD/A
Elec. spec.	37WGZ613
Layout	37LYF614
Eff. date	06-11-2024
CD Diagram	CD0006
Poles	04
Leads	3#12
Proprietary	False
Created date	03-14-2016

High Voltage Full Load Amps	23.3 a
Insulation Class	F
Inverter Code	Inverter Ready
KVA Code	J
Lifting Lugs	Standard Lifting Lugs
Locked Bearing Indicator	No Locked Bearing
Motor Lead Exit	Ko Box
Motor Lead Quantity/Wire Size	3 @ 12 AWG
Motor Lead Termination	Flying Leads
Motor Standards	NEMA
Motor Type	3734M
Mounting Arrangement	F1
Number of Poles	4
Overall Length	16.32 IN
Power Factor	77
Product Family	General Purpose
Pulley End Bearing Type	Ball
Pulley Face Code	Standard
Pulley Shaft Indicator	Standard
Rodent Screen	None
Service Factor	1.15
Shaft Diameter	1.375 IN
Shaft Extension Location	Pulley End
Shaft Ground Indicator	No Shaft Grounding
Shaft Rotation	Reversible
Shaft Slinger Indicator	No Slinger
Speed	1770 rpm
Speed Code	Single Speed
Starting Method	Direct on line
Thermal Device - Bearing	None
Thermal Device - Winding	None
Vibration Sensor Indicator	No Vibration Sensor
Winding Thermal 1	None
Winding Thermal 2	None

Nameplate

NP3553L									
CAT.NO.	EM3311T-8								
SPEC	37F614Z613G1								
HP	7.5								
VOLTS	200								
AMPS	23.3								
RPM	1770								
FRAME	213T		HZ	60		PH	3		
SF	1.15	CODE	J	DES	A	CLASS	F		
NEMA NOM. EFF	91	PF	77						
RATING	40C AMB-CONT								
CC	010A								
ENCL	OPSB	SER							
DE	6307	ODE	6206						
VPWM INVERTER READY									
CT30-60(2:1) VT3-60(20:1)									

Accessories

Part number	Description	Multiplier
37-1404	C FACE KIT	A8

AC Induction Motor Performance Data

Record # 57432

Typical performance - not guaranteed values

Winding: 37WGZ613-R001		Type: 3734M	Enclosure: OPSB		
Nameplate Data			200 V, 60 Hz: Single Voltage Motor		
Rated Output (HP)	7.5	Full Load Torque	22.2 LB-FT		
Volts	200	Start Configuration	direct on line		
Full Load Amps	23.3	Breakdown Torque	72 LB-FT		
R.P.M.	1770	Pull-up Torque	34 LB-FT		
Hz	60	Phase	3	Locked-rotor Torque	42.9 LB-FT
NEMA Design Code	A	KVA Code	J	Starting Current	168 A
Service Factor (S.F.)	1.15	No-load Current	11.8 A		
NEMA Nom. Eff.	91	Power Factor	77	Line-line Res. @ 25°C	0.29 Ω
Rating - Duty	40C AMB-CONT		Temp. Rise @ Rated Load	35°C	
S.F. Amps			Temp. Rise @ S.F. Load	43°C	
			Locked-rotor Power Factor	39.9	
			Rotor inertia	0.836 LB-FT ²	

Load Characteristics 200 V, 60 Hz, 7.5 HP

% of Rated Load	25	50	75	100	125	150	S.F.
Power Factor	38	59	71	77	81	82	79
Efficiency	84.6	90.2	91.1	91.1	90.5	89	90.7
Speed	1794	1788	1780	1774	1765	1755	1769
Line amperes	12.8	15.2	18.8	22.9	27.6	32.9	25.7

ABB Motors and Mechanical Inc.

WINDING # 37WGZ613

Typical performance - not guaranteed values.

7.5 HP 3 PH 60 HZ 1770 RPM 200 V 3734M

TORQUES (LB-FT): PO=72 PU=34 LR=42.9 LRA=168

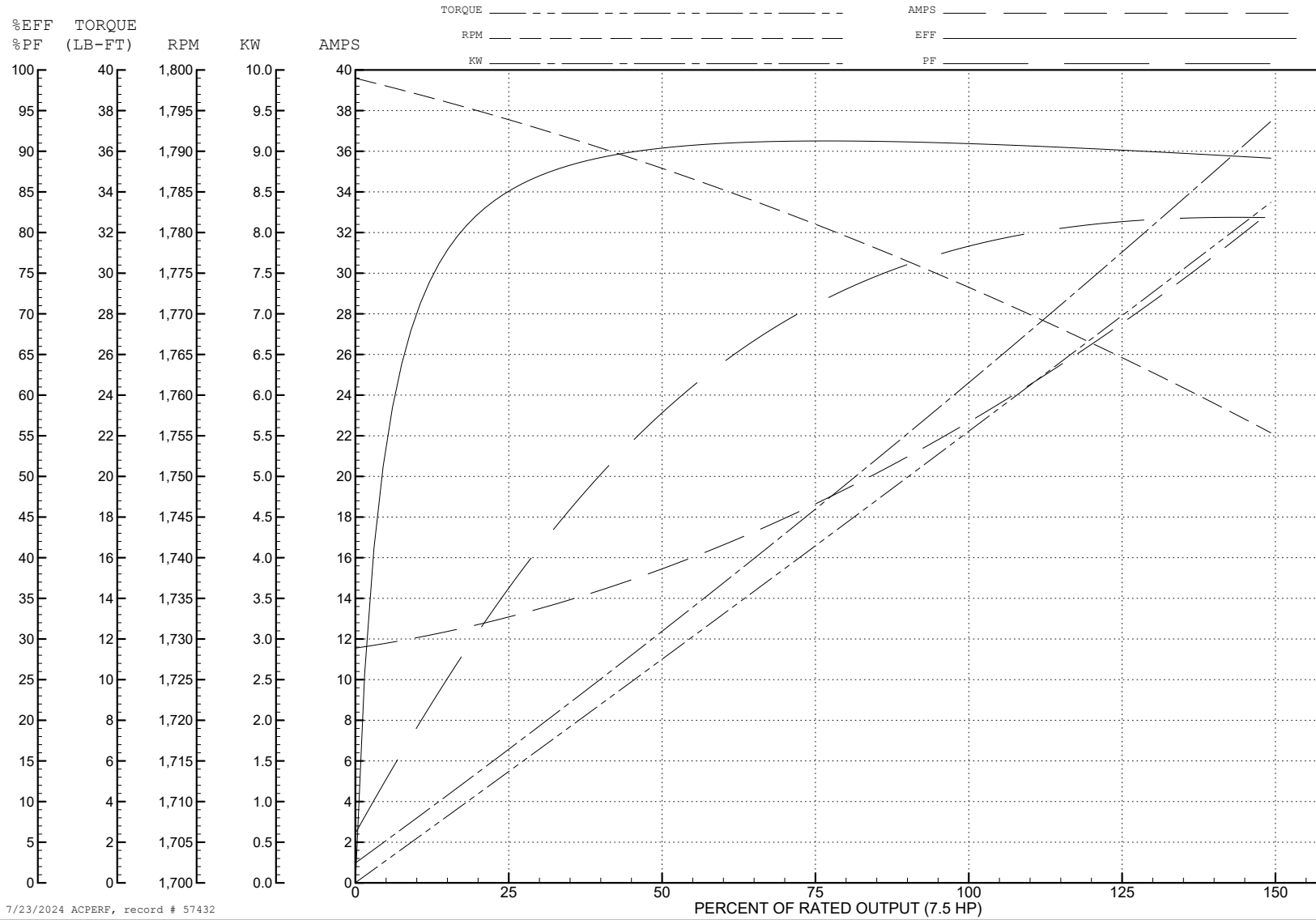

7/23/2024 ACPERF, record # 57432

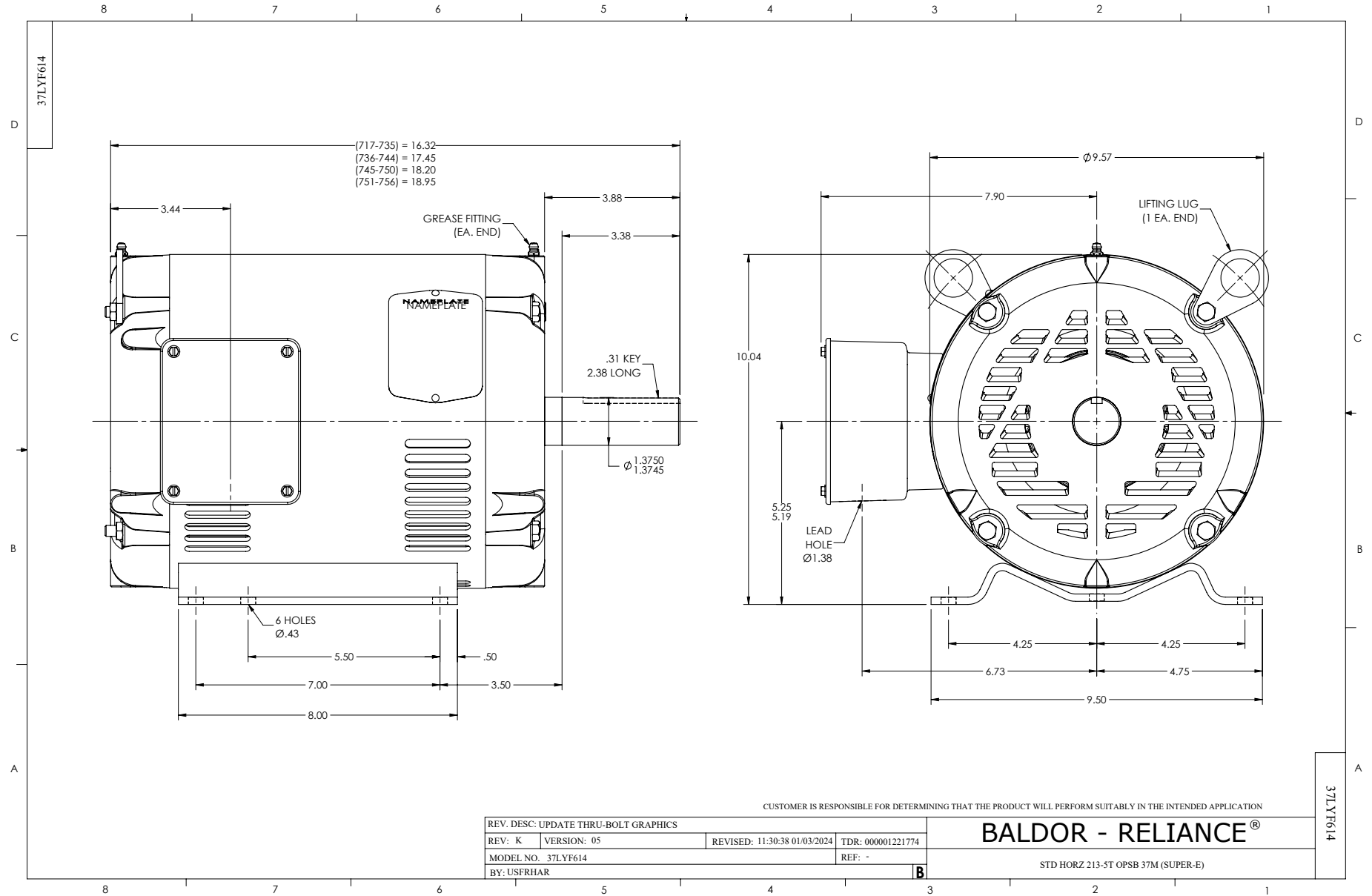

CD0006

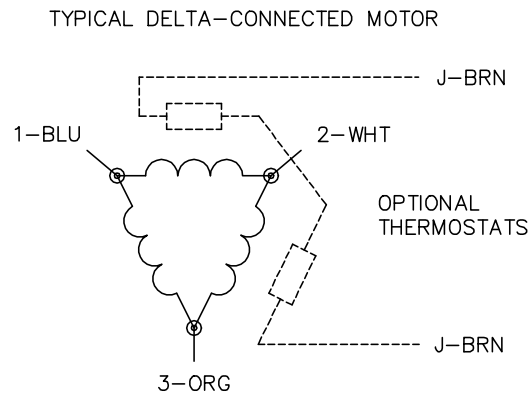
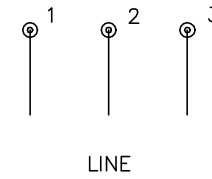
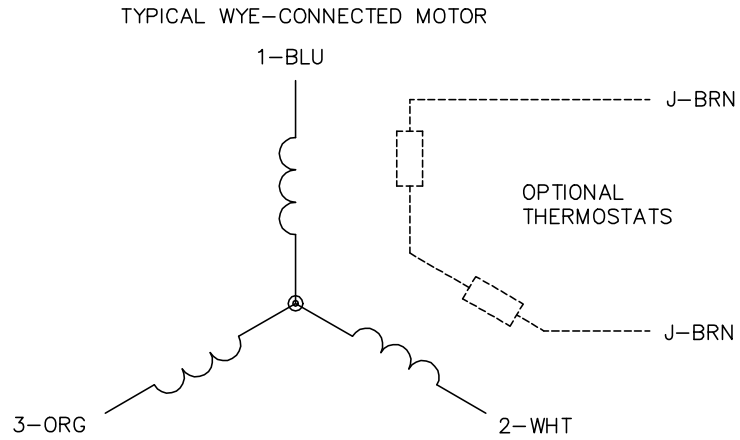

NOTES:

1. THREE LEAD MOTOR MAY BE EITHER WYE CONNECTED OR DELTA CONNECTED.
2. INTERCHANGE ANY TWO LINE LEADS TO REVERSE ROTATION.
3. OPTIONAL THERMOSTATS ARE PROVIDED WHEN SPECIFIED.
4. ACTUAL NUMBER OF INTERNAL PARALLEL CIRCUITS MAY VARY.
5. LEAD COLORS ARE OPTIONAL. LEADS MUST BE NUMBERED AS SHOWN.

CD0006

REV. DESC: ADD CLASS CONN00000007		
REV. LTR: E	VERSION: 01	TDR: 000001099922
FILE: \AAA\00005\141	REVISED: 10:24:49 02/19/2019	BY: ENBRIRO
MTL: -	© □	

BALDOR - RELIANCE®

3PH, SV, 3 LEADS, WYE OR DELTA CONNECTED

SH 1 of 1