

EP3

EP3 Series

Electropneumatic Transducer

Product Overview

The EP3 Series combines a microcontroller with high performance, low power coil poppet valve technology to create a system with unparalleled accuracy and proven reliability. The poppet valves used in the EP3 consume no air, eliminating unnecessary air losses in the system and allowing for efficient, long-term operation. The EP3 permits versatility, since all models feature manual override and a tri-state control option. The LCD provides easy visibility and the LED indicators provide visual status of valve operation in manual or automatic mode. All models come with SnapTrack housing and optional covers are available



NOTICE

- This product is not intended for life or safety applications.
- Do not install this product in hazardous or classified locations.
- Read and understand the instructions before installing this product.
- Turn off all power supplying equipment before working on it.
- The installer is responsible for conformance to all applicable codes.

If this product is used in a manner not specified by the manufacturer, the protection provided by the product may be impaired. No responsibility is assumed by the manufacturer for any consequences arising out of the use of this material.

*CE mark applies to models with cover only.

Product Identification

	Output	Feedback	Failsafe	Option
EP3	<input type="checkbox"/>	<input checked="" type="checkbox"/>	<input type="checkbox"/>	<input type="checkbox"/>
	0 = None 3 = Analog output: 0 to 10 Vdc or 4 to 20mA (selectable)	3 = Pressure Loss Alarm or Manual Mode Alarm	0 = None 1 = Vent on Power Fail	Blank = none 2 = EP Cover Plate

Specifications

Power Supply	Class 2, 22 to 30 Vdc, 20 to 30 Vac, 47 to 63 Hz, 150 mA max. average, 350 mA peak
Control Input	4 to 20 mA, (0 to 10 V, 0 to 5V; jumper selectable), Tri-State, PWM
Input Impedance	4 to 20 mA, 250 Ω; 0 to 5/0 to 10V, 10 kΩ
Manual Override	Digital pushbutton adjust, switch selectable mode
Alarm Contact	100 mA @ 30 Vac/dc (pressure loss, manual mode, jumper selectable)
Accuracy	1% F.S.; combined linearity, hysteresis, repeatability @ 20 °C ambient
Temperature Coefficient	±0.1%/°C
Operational Temp. Range	5 to 60 °C (41 to 140 °F)
Operating Humidity Range	10 to 90% RH, non-condensing
SCIM	523 in ³ /min @ 45 psi (8520 cm ³ /min @ 310.3 kPa); 333 in ³ /min @ 20 psi (5407 cm ³ /min @ 137.9 kPa)
Supply Pressure	Minimum (0.1 psi plus user F.S. pressure), maximum (45 psig)
Control Range	User programmable zero selectable from 0-25 psi: full scale 0-25 psi
Pressure Differential	0.1 psig (supply to branch)
Pressure Indication	Electronic, 3½ digit backlit LCD
Minimum Tubing Length	15 feet*
Port Connection	1/8-in. i.d. poly tubing
Media Connection	Clean dry air or inert gas. Not for use with oxygen service.
WARRANTY	
Limited Warranty	5 years
COMPLIANCE INFORMATION	
Agency Approvals	EMC Conformance: EN 61000-6-3 Class B:2007+A1 2011, EN 61000-6-1:2007, EN 61000-3-2:2000, EN 61000-3-3:2001

*For shorter tubing runs use AA45 Pneumatic Capacitor.

**EMC Special Note: Connect this product to a DC distribution network or an AC/DC power adaptor with proper surge protection (EN 61000-6-1:2007 specification requirements)

Dimensions

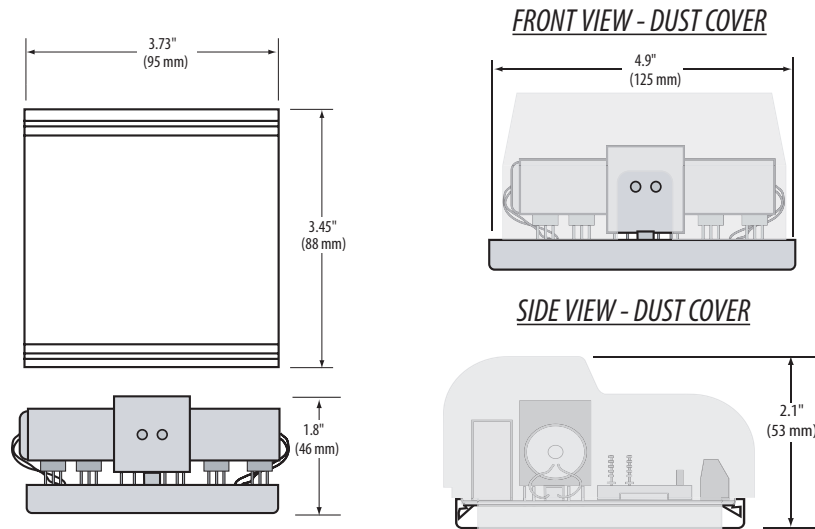

Installation



Observe precautions for handling static sensitive devices to avoid damage to the circuitry that is not covered under the factory warranty.

1. Mount the EP3 transducer using the screws provided.
2. Configure the jumpers for desired operation as shown (page 2).
3. Wire the transducer as shown in the wiring diagram (page 3).
4. Attach pressure tubing to the hose barbs. Observe MAIN and BRANCH port labels. Use flexible 1/8" I.D. poly tubing for main and branch pneumatic connections. **Main supply pressure must not exceed 45 psig.**

Configuration

Switch/Jumper	Description
Input	User selectable slide switch: current (4-20 mA), voltage (0-5/0-10 V), Tristate, or PWM (min 0.01-0.60 sec, max 1.0-75.0 sec). Note: the Network Control option is disabled.
Input Voltage*	If voltage input is selected, use this jumper to choose 0 to 5 or 0 to 10 V.
Tri Pull-up	If tristate input is selected, use this jumper to turn the pull-up on or off.
Alarm	Phase loss or manual
Output	Use this jumper to select 4-20 mA or 0-10 V output (feedback status for branch pressure).
Setting	User selectable slide switch: Tristate timing (min 1 sec; max 600 sec, default 60 sec), FS Point (scale point user programmable 0-25 psi), Zero (user programmable 0-25 psig), Run. Note: the Network option is disabled.
Mode	Auto for normal operation; Manual to adjust pressure. Set this jumper last.

* EP3 accepts DC input only. To use with AC input, include a Veris AA49 Triac Adapter in series between the input voltage and the EP3.

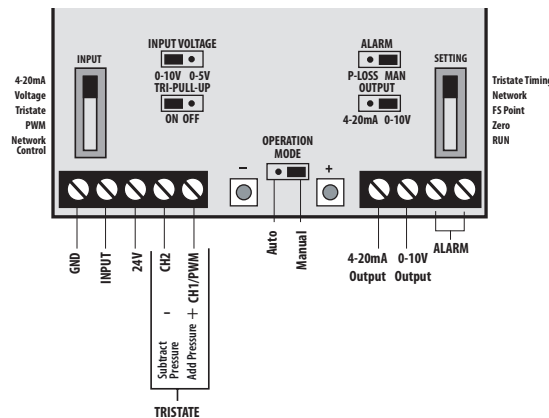

Wiring

Current/voltage Control, Voltage Output Example

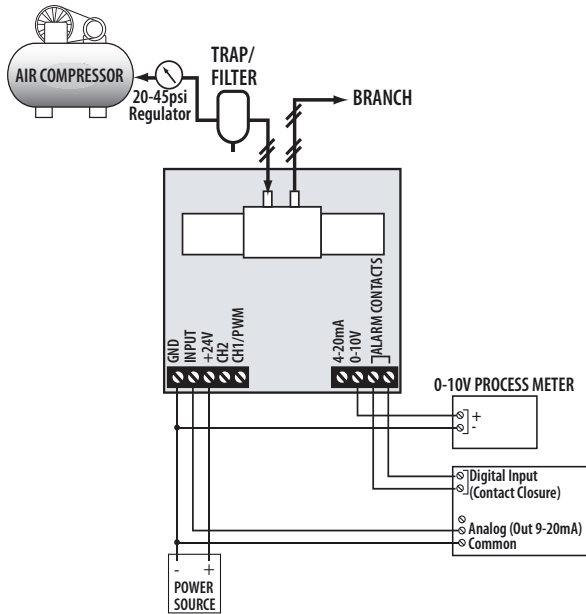

- Input switch set to voltage (0-5VDC or 0-10VDC)
- Input volt jumper set to either 0-5VDC or 0-10VDC
- Input switch set to 4-20mA
- Output jumper set to 0-10VDC

Current/voltage Control, Current Output Example

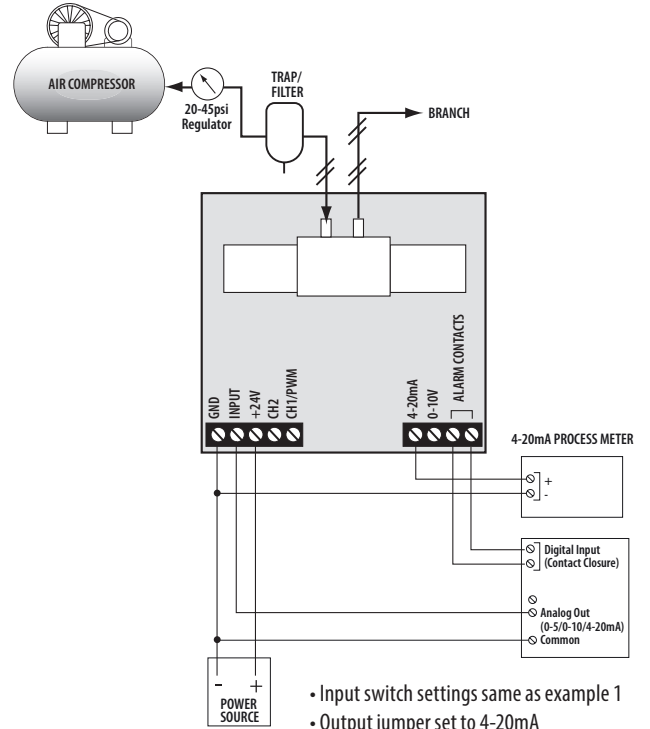

- Input switch settings same as example 1
- Output jumper set to 4-20mA

PWM Control Example

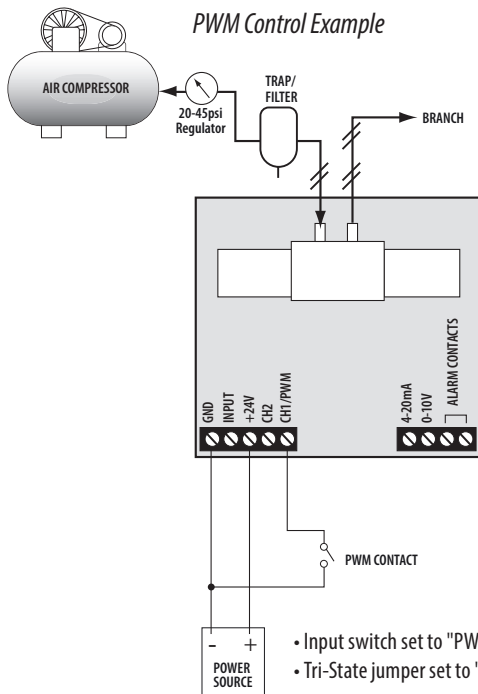

- Input switch set to "PWM"
- Tri-State jumper set to "ON"

Tri-state Control Example

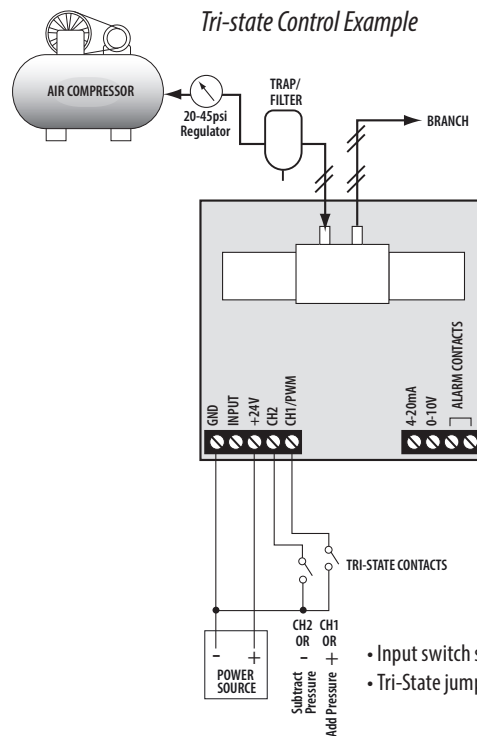

- Input switch set to "TRI-STATE"
- Tri-State jumper set to "ON"

Special Instructions

PWM Mode

To set the minimum pulse value, adjust the Input and Setting switches as shown:



"LO" momentarily appears on the LCD, indicating that the minimum pulse width is being set. Use the (+) and (-) buttons to increase or decrease this value. To set the maximum pulse width push both buttons simultaneously. "HI" momentarily appears, indicating that the maximum pulse width is being set. Push both buttons to toggle between the "HI" and "LO" settings. To save these settings, move the Setting slide switch to RUN.

If the controller receives a pulse that is shorter than the minimum pulse width, the output goes to 0% of the range set with the zero and span settings. If the controller sees a pulse that is the same or longer than the maximum pulse width, the output goes to 100% of the range selected with the zero and span settings.

In this example the minimum pulse width is set to 0.60 sec, the maximum is set to 10 sec, zero is set to 0, and span is set to 10 psi. Assume the controller receives a pulse of 5 sec duration:

$$\begin{aligned} \text{Pulse range} &= 10 \text{ sec} - 0.60 \text{ sec} = 9.4 \text{ sec} \\ \text{Pressure range} &= \text{span} - \text{zero} = 10 - 0 = 10 \\ \text{Output} &= (5 / 9.4) \times 10 = 5.3 \text{ psi} \end{aligned}$$

Tristate Mode

Traveltime is defined as the contact closure time required to go from zero to full scale. If traveltime is set to 10 seconds and the TRISTATE 1 input is connected to ground for 5 seconds, the output is 50%. If the input is connected to ground for another 5 seconds, the output is 100%. If TRISTATE 2 (the decreasing input) is grounded for 10 seconds, the products output return to 0%.

To set the travel time, adjust the Setting and Input switches as shown:

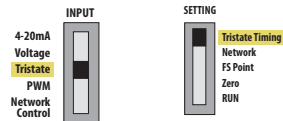

Press the (+) or (-) buttons to increase or decrease the travel time. Minimum travel time is 1 second; maximum is 600 seconds. To save these settings, move the Setting slide switch to RUN. The device's internal counters measure the contact closure time with 100 Hz resolution.

Note: If Tristate input is to be operated by a triac output (Veris AA49), use an AC relay to provide a dry contact closure to the EP3 input.

Tubing Length

Minimum tubing length is 15 feet or an equivalent volume of 2.2 cubic inches. Shorter tubing lengths cause the unit to oscillate.

Analog Output

The output is generated from the branch pressure. It is calculated as follows:

FS = Full Scale Point
Zero = Zero setting

In volt mode:

$$\begin{aligned} \text{Pressure} &= (10 / (\text{FS} - \text{Zero})) * \text{Voltage} + \text{Zero} \\ \text{Voltage} &= (\text{Pressure} - \text{Zero}) / (\text{FS} - \text{Zero}) * 10 \end{aligned}$$

In current mode:

$$\begin{aligned} \text{Pressure} &= (\text{FS} - \text{Zero}) * ((\text{Current} - 4) / 16) + \text{Zero} \\ \text{Current (in mA)} &= ((\text{Pressure} - \text{Zero}) / (\text{FS} - \text{Zero})) * 16 + 4 \end{aligned}$$

Special Instructions (cont.)

Examples:

Zero setting = 5 psi; Span = 20 psi; Branch pressure = 16 psi
 Volt mode: Voltage = $((16 - 5) / (20 - 5)) * 10 = 7.33 \text{ V}$
 Current mode: Current = $((16 - 5) / (20 - 5)) * 16 + 4 = 15.73 \text{ mA}$

Alarms

Auto Mode: Alarm contacts are closed in normal operation and are open when no power is applied or when the device is in an alarm state.

Manual Mode: Alarm contacts are open in manual mode setting and closed for normal operation. Move the P-LOSS/MAN jumper to the manual mode setting. You do not need to power cycle the product after moving jumpers.

Pressure Loss Alarm: Contacts open when the branch pressure falls and stays below 20% of the desired pressure for a period of 2 minutes.

FS Point and Zero Setting

To set the Zero or FS point, move the SETTING slide switch from Run to Zero or FS point setting, respectively.

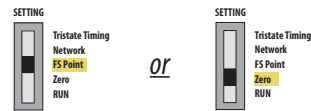

The 'Set' icon appears on the LCD. Use the (+) and (-) buttons to increase or decrease the pressure setpoints.

LED Blink Codes

Slow green	Normal operation
Slow green with one fast red	Manual mode alarm (contacts open)
Slow green with two fast reds	Pressure loss alarm active (contacts open)
Slow red	SETTINGS slide switch not in Run position
Two fast reds	Settings slide switch not in Run position and Alarm (contacts open)
Three fast reds	Over-voltage or over-current fault
Four fast reds	Over pressure on branch side; over 25 psi.