

PRODUCT INFORMATION PACKET



Model No: EM3729F
Catalog No: EM3729F

PRO-E SERIES® Condenser Fan Motor, 1/3 HP, 1 Ph, 60 Hz, 208-230 V, 1075 RPM, 1 Speed, 48 Frame, TEAO



Regal and Century are trademarks of Regal Rexnord Corporation or one of its affiliated companies.
©2023 Regal Rexnord Corporation, All Rights Reserved. MC017097E





Nameplate Specifications

Phase	1	Output HP	1/3 Hp
Output KW	0.25 kW	Voltage	208-230 V
Speed	1075 rpm	Service Factor	1
Frame	48Y	Enclosure	Totally Enclosed Air Over
Thermal Protection	Automatic	Ambient Temperature	70 °C
Frequency	60 Hz	Current	2.2-2.5 A
Duty	Air Over	Insulation Class	F
UL	Recognized	CSA	Y
CE	N	Number of Speeds	1

Technical Specifications

Electrical Type	Permanent Split Capacitor	Starting Method	Across The Line
Poles	6	Rotation	Reversible
Mounting	Extended Studs	Motor Orientation	Any
Drive End Bearing	Ball	Opp Drive End Bearing	Ball
Frame Material	Rolled Steel	Shaft Type	Flat
Overall Length	11.17 in	Frame Length	4.69 in
Shaft Diameter	0.500 in	Shaft Extension	6.0 in
Outline Drawing	EM3729F_FA	Connection Drawing	614131-292

This is an uncontrolled document once printed or downloaded and is subject to change without notice. Date Created:08/01/2023

GENERAL INFORMATION:

SHAFT RUNOUT: .001 [.03] T.I.R. PER INCH LENGTH OF EXTENSION

BEARINGS: BALL

MOUNTING POSITION: ALL ANGLE

ELECTRICAL DATA:

OVERLOAD PROTECTOR: AUTOMATIC RESET (T.I. 7AM 036)

LEADS: NO. 18 GA., .03 [.8] THK., XLP 125°C INSUL.

GROUND LEAD: NO. 18 GA., .03 [.8] THK. (GREEN) INSUL.

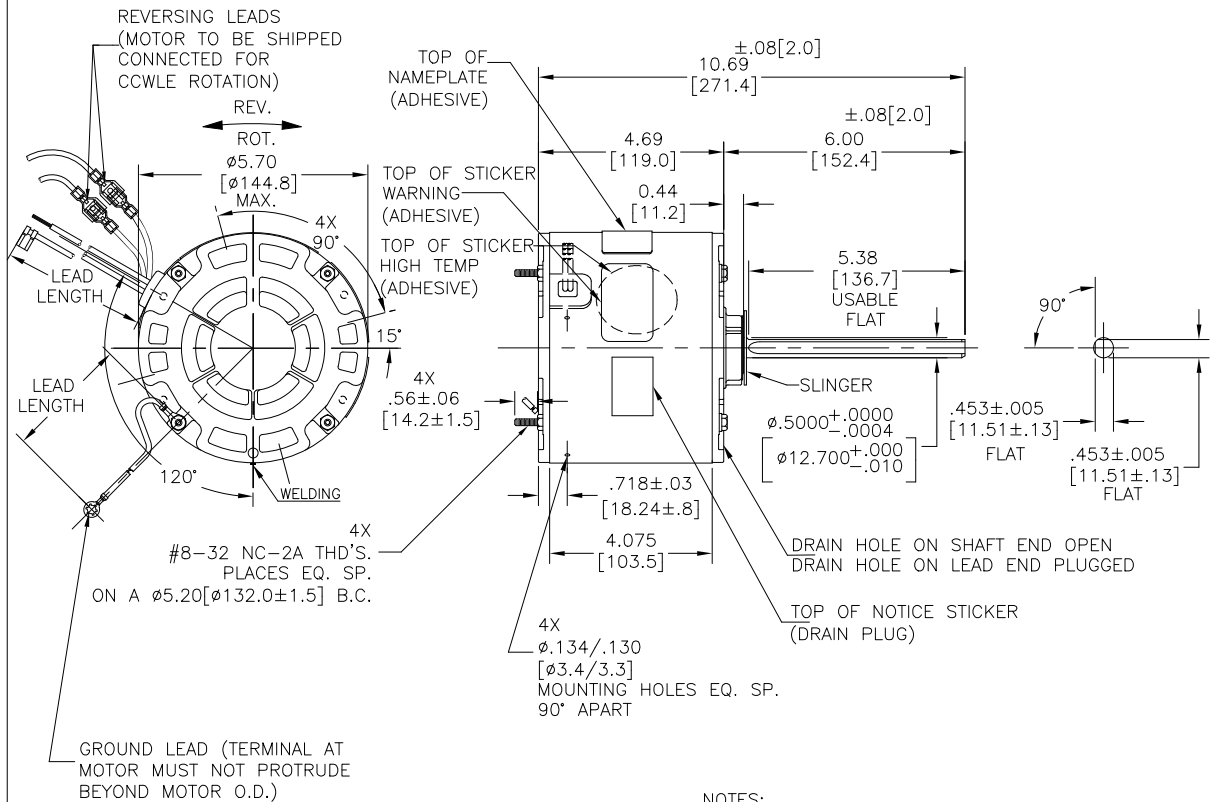

GROUND LEAD (TERMINAL AT MOTOR MUST NOT PROTRUDE BEYOND MOTOR O.D.)

NOTES:

1. CENTURY OUTSIDE MOTOR SERIES.
2. 4X SCREWS N194P1504B9 & 4X HEX NUTS N238P15B9 TO BE PUT IN A POLYBAG
3. SPRING SHIM IN LE SIDE.
4. ALL LABEL READ FROM LE

REGAL-BELOIT CORPORATION (RBC) PROVIDES TECHNICAL ASSISTANCE TO OUR CUSTOMERS IN SEVERAL AREAS. SINCE RBC DOES NOT RECEIVE ALL DATA CONCERNING THE USE AND APPLICATION OF THE MOTOR, THE SUITABILITY OF THE MOTOR FOR THE APPLICATION MUST BE DETERMINED BY THE CUSTOMER.

DIMENSIONS WITHOUT TOLERANCES ARE FOR REFERENCE ONLY.

MAIN FRAME - OLE	ENCLOSED
END FRAME - OLE	ENCLOSED
MAIN FRAME - LE	ENCLOSED
END FRAME - LE	ENCLOSED

CUSTOMER CENTURY

GREEN (GROUND)	12.0/13.0 [305/330]	#10 EYELET
PURPLE (REV)	4.0/6.0 [102/152]	.25[6.4] PER-INSUL. MALE TAB
PURPLE (REV)	4.0/6.0 [102/152]	.25[6.4] PER-INSUL. FEMALE SPADE
YELLOW (REV)	4.0/6.0 [102/152]	.25[6.4] PER-INSUL. MALE TAB
YELLOW (REV)	4.0/6.0 [102/152]	.25[6.4] PER-INSUL. FEMALE SPADE
BROWN/WHITE	35.0/37.0 [889/940]	.25 [6.4] FLAG
BROWN	35.0/37.0 [889/940]	.25 [6.4] FLAG
WHITE	35.0/37.0 [889/940]	.50 [12.7] SKIN
BLACK	35.0/37.0 [889/940]	.50 [12.7] SKIN
COLOR	LENGTH	TERMINAL OR STRIP LENGTH

LEAD DATA

DRAWING REVISION	REVISION BY	DATE
C	MG	07.01.2022
ECO	APPROVED BY	DATE
ECR-0212494	LS	07.01.2022
ECO DESCRIPTION		
HIGH TEMP STICKER ADDED IN MOTOR VIEW		
<small>COPYRIGHT REGAL-BELOIT AMERICA, INC. ALL RIGHTS RESERVED. PROPRIETARY AND CONFIDENTIAL INFORMATION - THIS DOCUMENT IS THE PROPERTY OF REGAL-BELOIT AMERICA, INC. (OWNER) AND CONTAINS OWNER'S PROPRIETARY INFORMATION. ANY PERSON, CORPORATION OR OTHER FIRM RECEIVING IT IS DEMAND, BY RECEIVING IT, TO AGREE THAT IT, AND/OR ANY PART OF IT, SHALL NOT BE DISCLOSED TO ANY PERSON, CORPORATION OR OTHER ENTITY, DUPLICATED, AND/OR USED, EXCEPT AS EXPRESSLY APPROVED IN WRITING IN ADVANCE BY OWNER. THIS DOCUMENT SHALL BE RETURNED TO OWNER UPON REQUEST. IT MAY BE SUBJECT TO CERTAIN RESTRICTIONS UNDER APPLICABLE EXPORT CONTROL LAWS AND REGULATIONS.</small>		

ENCLOSURE

DRAWN BY: MANOJ	Regal Beloit America, Inc.
DATE: 24.03.19	
APPROVED BY: LAXMAN SINGH	DESCRIPTION: MODEL-RFHP-48FR OUTLINE
DATE: 24.03.19	MATERIAL: -
PROCESS/FINISH: -	SIZE DWG NO: EM3729F_FA
THIRD ANGLE PROJECTION	SHEET 1

NAMEPLATE DATA:	EXTERNAL CONNECTION DIAGRAM
MODEL NO.: 5KCP39KGDD594S CUST. P/N: EM3729F HP: 1/3 ROT.: REVERSIBLE RPM: 1075 TYPE: UF FRAME: 48Y VOLTS: 208-230 PH: 1 AMPS: 2.2-2.5 HZ: 60 INS.: F AMB.: 70°C DUTY: AIR OVER CAP.: 7.5MFD/370V THERMALLY PROTECTED	<p>SEP. CAP. BROWN</p> <p>BRN/WHT</p> <p>WHITE</p> <p>BLACK</p> <p>LINE</p> <p>ROTATION AT LEAD END</p> <p>YELLOW CCW PURPLE</p> <p>YELLOW CW PURPLE</p> <p>YELLOW CW YELLOW</p> <p>PURPLE PURPLE</p> <p>614131-292</p>
E27885 MADE IN INDIA	

REV	ECO	REV BY	DATE	APPD	DATE
B	ECO-0022458	jrupert	09-19-2011	jrupert	09-19-2011

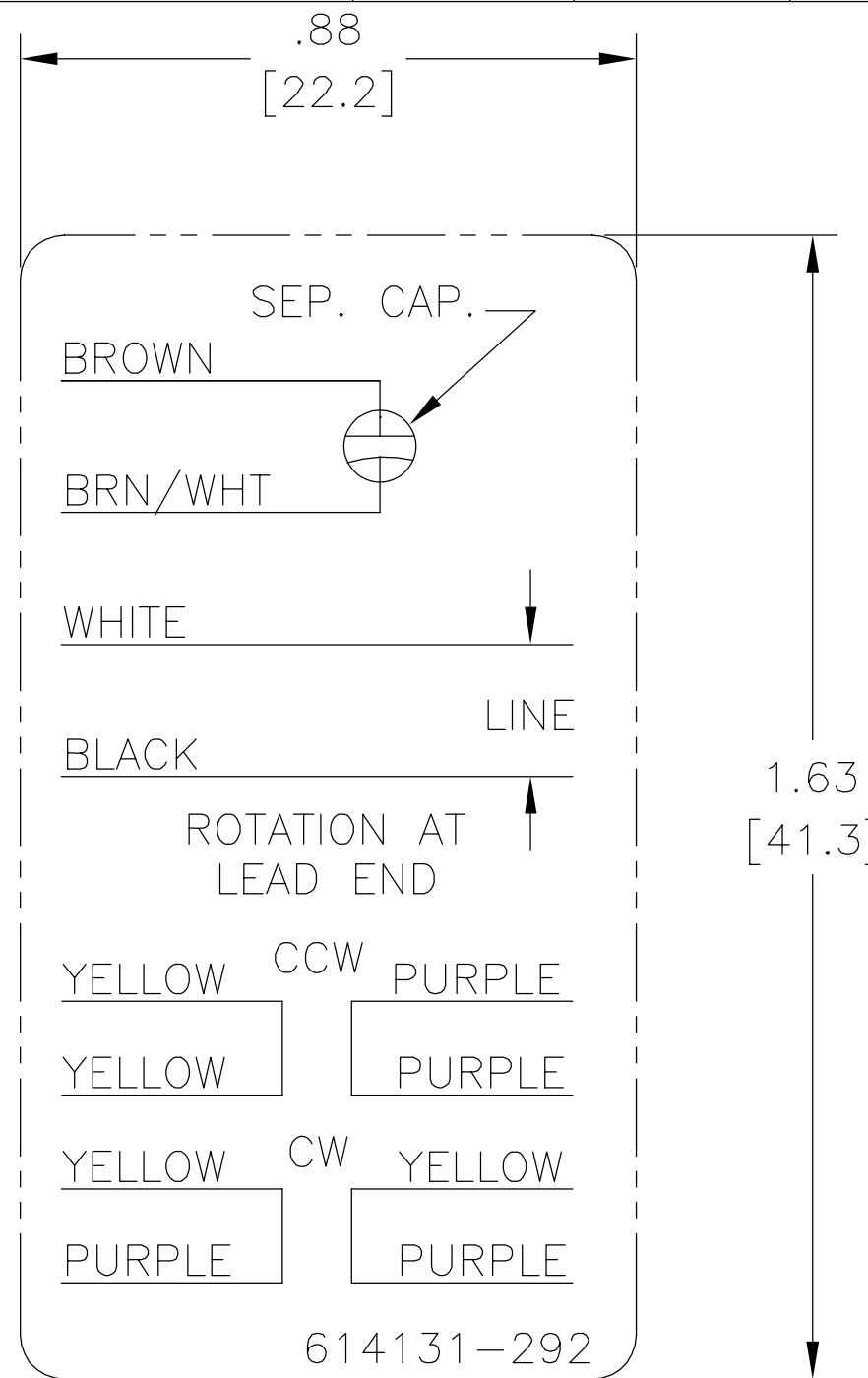

NOTES:

1. FOR USE WITH 614129 NAMEPLATE BLANK
2. ——— ——— INDICATES DIMENSION LIMITS
3. DIE TO BE MADE FROM MASTER SUPPLIED BY A. O. SMITH CORPORATION
4. DIE MUST PRODUCE A LEGIBLE IMPRESSION.

GEOMETRIC CHARACTERISTICS & SYMBOLS

- ▭ FLATNESS
- STRAIGHTNESS
- ∠ ANGULARITY
- ⊥ PERPENDICULARITY (SQUARENESS)
- // PARALLELISM
- ROUNDNESS (CIRCULARITY)
- ⊘ CYLINDRICITY
- △ PROFILE OF ANY SURFACE
- ∩ PROFILE OF ANY LINE
- ↑ RUNOUT
- ⊕ TRUE POSITION
- ◎ CONCENTRICITY
- ≡ SYMMETRY

UNLESS OTHERWISE SPECIFIED
DIM. TOLERANCES ARE AS FOLLOWS:

INCH	±.1	±.02	±.005	±.0005
mm	±0.5	±0.13	±0.013	

ANG. ±.50 DEG

REMOVE BURRS & BREAK SHARP EDGES:
INCH .003-.015 mm 0.1-0.4

CORNER FILLETS TO:
INCH .020 mm 0.5

MACHINE SURFACES:
INCH 125 mm 3.2

METRIC DIMS. SHOWN IN [BRACKETS]

DR BY:	jrupert	09-19-2011
APPD:	jrupert	09-19-2011
THIRD ANGLE PROJECTION		EDS DATE 02-22-2008 FORMAT REV F
CONFIDENTIAL: THIS DRAWING AND ITS INFORMATION ARE THE EXCLUSIVE AND CONFIDENTIAL PROPERTY OF A.O. SMITH CORP. AND ARE NOT TO BE DISCLOSED, DUPLICATED, DISTRIBUTED OR OTHERWISE USED WITHOUT THE WRITTEN CONSENT OF A.O. SMITH CORP. -ALL RIGHTS RESERVED. ASME Y14.5M 1994		

ELECTRICAL PRODUCTS COMPANY <small>INNOVATION HAS A NAME. A DIVISION OF A. O. SMITH CORPORATION</small>	
DESCRIPTION CONN DIAGRAM NAMEPLATE	
SIZE A	DWG NO 614131-292
SCALE NONE	SHEET 1

REVISION:	ECO	REVISADO POR:	FECHA:	APROBADO POR:	FECHA:
B	ECO-0022458	jrupert	09-19-2011	jrupert	09-19-2011

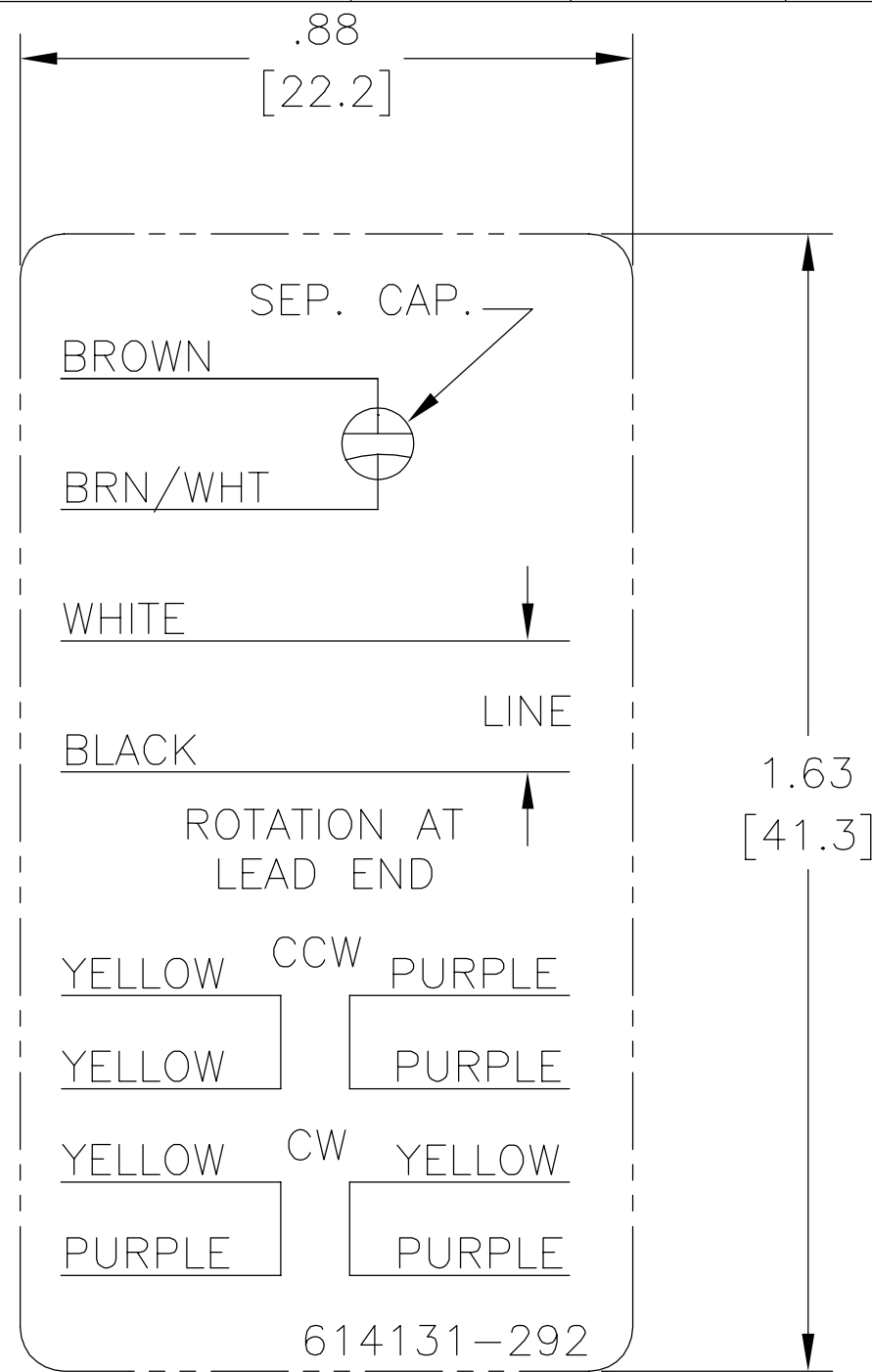

NOTES:

1. FOR USE WITH 614129 NAMEPLATE BLANK
2. ——— ———— INDICATES DIMENSION LIMITS
3. DIE TO BE MADE FROM MASTER SUPPLIED BY A. O. SMITH CORPORATION
4. DIE MUST PRODUCE A LEGIBLE IMPRESSION.

CARACTERISTICAS DE GEOMETRIA Y SIMBOLOS ▽ PLANICIDAD — RECTITUD < ANGULARIDAD ⊥ PERPENDICULARIDAD (A ESCUADRA) // PARALELISMO ○ REDONDEZ (CIRCULARIDAD) ∅ CILINDRICIDAD △ PERFIL DE CUALQUIER SUPERFICIE ∩ PERFIL DE CUALQUIER LINEA ↑ VARIACION ⊕ POSICION REAL ⊙ CONCENTRICIDAD = SIMETRIA

A MENOS QUE SE ESPECIFIQUE DE OTRA MANERA, LAS TOLERANCIAS DE LAS DIMS; SON LAS SIGUIENTES: X XX XXX XXXX PULG ±.1 ±.02 ±.005 ±.0005 mm ±0.5 ±0.13 ±0.013 ANG. ±.50 GRADOS ELIMINAR REBABAS Y ORILLAS FILOSAS DEL BORDE. PULG .003-.015 mm 0.1-0.4 FILETEAR ESQUINA: PULG .020 mm 0.5 MAQUINAR SUPERFICIES PULG 125 mm 3.2 DIMS METRICAS MOSTRADAS [PARENTESIS]

DIBUJADO POR:	jrupert	09-19-2011
APROBADO POR:	jrupert	09-19-2011
TERCER ANGULO DE PROYECCION		FECHA EDS: 02-22-2008 REV. FORMATO: F
CONFIDENCIAL: ESTE DIBUJO Y SU INFORMACION SON PROPIEDAD DE USO EXCLUSIVO Y CONFIDENCIAL DE A.O.SMITH CORP. Y NO DEBERAN SER REVELADOS, DUPLICADOS, DISTRIBUIDOS O USARSE DE OTRA MANERA SIN EL CONSENTIMIENTO ESCRITO DE A.O. SMITH CORP. -TODOS LOS DERECHOS RESERVADOS.ASME Y14.5M 1994		

ELECTRICAL PRODUCTS COMPANY A DIVISION OF A. O. SMITH CORPORATION	
DESCRIPCION:	
CONN DIAGRAM NAMEPLATE	
TAMAÑO: A	NUMERO DE DIBUJO: 614131-292
ESCALA: NONE	HOJA: 1

版本	ECO	编制	日期	批准	日期
B	ECO-0022458	jrupert	09-19-2011	jrupert	09-19-2011

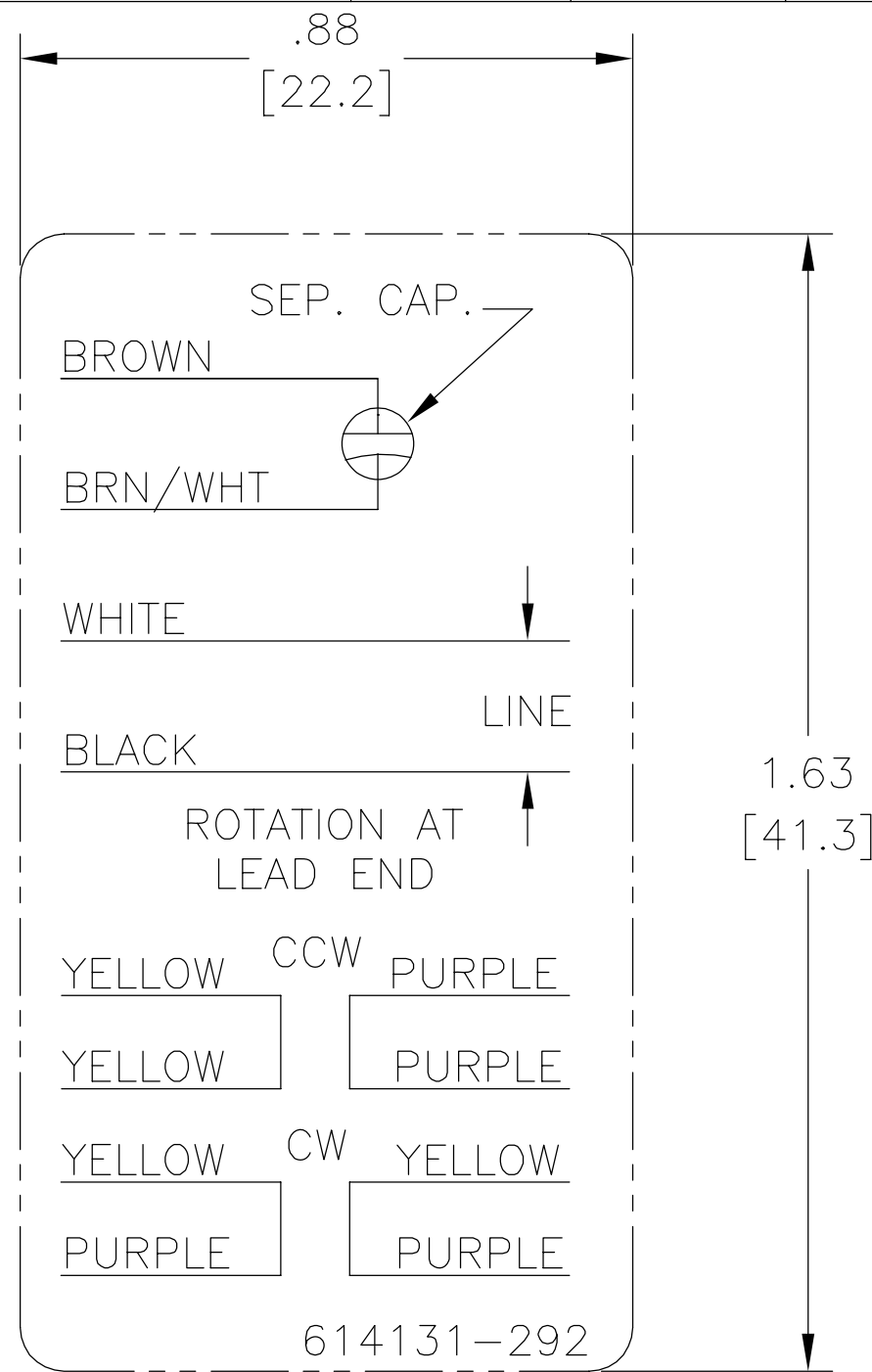

NOTES:

1. FOR USE WITH 614129 NAMEPLATE BLANK
2. — — — — — INDICATES DIMENSION LIMITS
3. DIE TO BE MADE FROM MASTER SUPPLIED BY A. O. SMITH CORPORATION
4. DIE MUST PRODUCE A LEGIBLE IMPRESSION.

形位公差	除另有注明
□ 平面度	尺寸公差如下:
— 直线度	英寸 X XX XXX XXXX
∠ 倾斜度	英寸 ±.1 ±.02 ±.005 ±.0005
⊥ 垂直度	毫米 ±0.5 ±0.13 ±0.013
// 平行度	角度 ±.50 度
○ 圆度	清理毛刺和尖棱
⊘ 圆柱度	英寸 .003-.015 毫米 0.1-0.4
△ 面轮廓度	内圆角
∩ 线轮廓度	英寸 .020 毫米 0.5
↗ 圆跳动	表面粗糙度
⊕ 位置度	英制 125 米制 3.2
◎ 同轴度	米制尺寸显示在 []
≡ 对称度	

绘图:	jrupert	09-19-2011
批准:	jrupert	09-19-2011
第三角投影		图纸格式发布日期 02-22-2008 图纸格式版本 F
机密: 本图纸及相关信息所有权归A. O. SMITH公司所有。未经A. O. SMITH公司书面授权, 不得泄露、复制、传播或作其他用途。—版权所有		
ASME Y14.5M 1994		

		ELECTRICAL PRODUCTS COMPANY <small>A DIVISION OF A. O. SMITH CORPORATION</small>	
名称 CONN DIAGRAM NAMEPLATE			
图幅	A	图号	614131-292
比例	NONE	页号	1

		ELECTRICAL PRODUCTS COMPANY <small>A DIVISION OF A. O. SMITH CORPORATION</small>	
名称 CONN DIAGRAM NAMEPLATE			
图幅	A	图号	614131-292
比例	NONE	页号	1