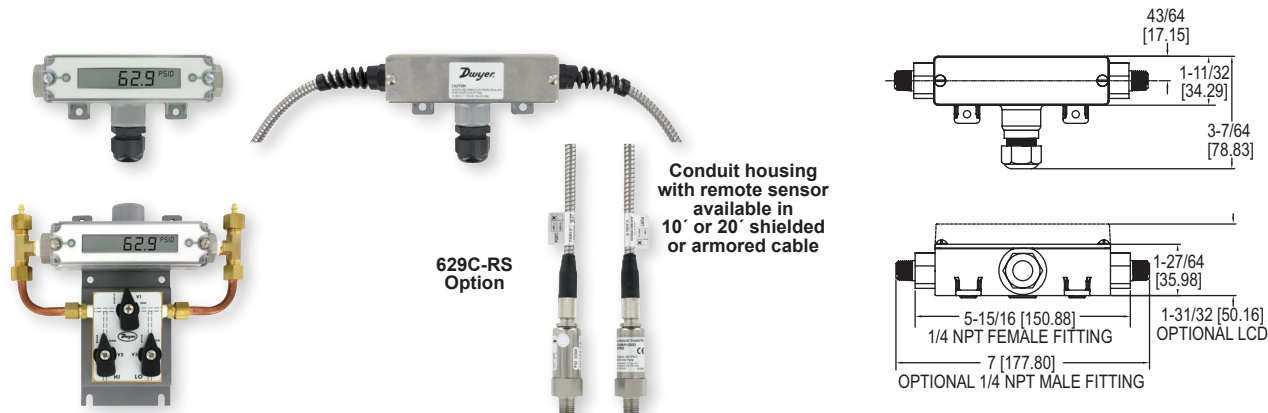




# Series 629C Wet/Wet Differential Pressure Transmitter

## Specifications - Installation and Operating Instructions



The **Series 629C Wet/Wet Differential Pressure Transmitter** monitors differential pressure of compatible gases and liquids with 0.5% accuracy. The design employs dual pressure sensors converting pressure changes into a 4 to 20 mA or voltage output signal. Small internal volume and minimal moving parts result in exceptional response and reliability. The wiring terminals and zero adjustment button are easily accessed under the removable cover. The Series 629C is designed to meet NEMA 4X (IP66) weatherproof construction.

SPECIFICATIONS	
<b>Service:</b>	Compatible gases and liquids.
<b>Wetted Materials:</b>	Without valve: 316, 316L SS. Additional wetted parts with valve option: Buna-N, silicone grease, PTFE, brass 360, copper, and reinforced copolymer.
<b>Accuracy:</b>	±0.5% FS (includes linearity, hysteresis & repeatability).
<b>Stability:</b>	±1% FS/year.
<b>Temperature Limits:</b>	0 to 200°F (-18 to 93°C).
<b>Compensated Temperature Limits:</b>	0 to 175°F (-18 to 79°C).
<b>Pressure Limits:</b>	See Table 1.
<b>Thermal Effects:</b>	Avg 0.04%/°F (0.072%/°C) (includes zero and span).
<b>Power Requirements:</b>	2-wire: 10 to 35 VDC; 3-wire: 13 to 35 VDC or isolated 16 to 33 VAC (reverse polarity protected).
<b>Output Signal:</b>	2-wire: 4 to 20 mA; 3-wire: Field selectable 0 to 5, 1 to 5, 0 to 10, or 2 to 10 VDC.
<b>Zero and Units:</b>	Push buttons inside conduit enclosure.
<b>Response Time:</b>	400 msec.
<b>Loop Resistance:</b>	Current output: 0 to 1250 Ω (max), Rmax = 50(Vps-10); Voltage output: Minimum load resistance = 5 kΩ.
<b>Current Consumption:</b>	28 mA (max).
<b>Electrical Connections:</b>	Removable terminal block; 1/2" female NPT conduit.
<b>Process Connections:</b>	1/4" female or male NPT.
<b>Display:</b>	Optional 4-1/2 digit LCD field attachable display.
<b>Enclosure Rating:</b>	Designed to meet NEMA 4X (IP66) for non-LCD models.
<b>Mounting Orientation:</b>	Not position sensitive.
<b>Weight:</b>	10.1 oz (286 g).
<b>Agency Approvals:</b>	CE.

RANGE			
Range Number	Range	Working Pressure*	Over Pressure
01	0 to 5 psid	10 psi	50 psi
02	0 to 10 psid	20 psi	50 psi
03	0 to 25 psid	50 psi	120 psi
04	0 to 50 psid	100 psi	250 psi
05	0 to 100 psid	200 psi	500 psi
06	0 to 150 psid	300 psi	750 psi
07	0 to 200 psid	400 psi	1000 psi
08	0 to 300 psid	600 psi	1200 psi
09	0 to 500 psid	1000 psi	2000 psi
11	0 to 0.5 bar differential	1 bar	3 bar
12	0 to 1 bar differential	2 bar	8 bar
13	0 to 2 bar differential	4 bar	8 bar
14	0 to 4 bar differential	8 bar	18 bar
15	0 to 6 bar differential	12 bar	18 bar
16	0 to 10 bar differential	20 bar	50 bar
17	0 to 15 bar differential	30 bar	60 bar
18	0 to 20 bar differential	40 bar	80 bar
19	0 to 30 bar differential	60 bar	120 bar

\*Pressures exceeding the working pressure limit may cause a calibration shift of up to ±3% of full scale.

**Note:** Over pressure of all models with 3-way valve is 100 psi.

Table 1: Pressure Limits

MODEL CHART								
Example	629C	-01	-CH	-P1	-E1	-S1	-3V	629C-01-CH-P1-E1-S1-3V
Series	629C							Wet/wet differential pressure transmitter
Range		01						0 to 5 psid
		02						0 to 10 psid
		03						0 to 25 psid
		04						0 to 50 psid
		05						0 to 100 psid
		06						0 to 150 psid
		07						0 to 200 psid
		08						0 to 300 psid
		09						0 to 500 psid
		11						0 to 0.5 bar differential
		12						0 to 1 bar differential
		13						0 to 2 bar differential
		14						0 to 4 bar differential
		15						0 to 6 bar differential
		16						0 to 10 bar differential
		17						0 to 15 bar differential
		18						0 to 20 bar differential
		19						0 to 30 bar differential
Housing			CH					Conduit housing, NEMA 4X (IP66)
			R1					Conduit housing, NEMA 4X (IP66), with remote sensor and 10' shielded cable
			R2					Conduit housing, NEMA 4X (IP66), with remote sensor and 20' shielded cable
			R5					Conduit housing, NEMA 4X (IP66), with remote sensor and 10' armored cable
			R6					Conduit housing, NEMA 4X (IP66), with remote sensor and 20' armored cable
Process Connection				P1				1/4" male NPT
				P2				1/4" female NPT
				P3				1/4" male BSPT
				P4				1/4" female BSPT
Electrical Connection					E1			Cable gland with 3' of prewired cable
					E2			Cable gland with 6' of prewired cable
					E3			Cable gland with 9' of prewired cable
					E5			1/2" female NPT conduit
					E9			M-12 4 pin connector (not UL)
Signal Output						S1		4 to 20 mA
						S3		Field selectable 0 to 5, 1 to 5, 0 to 10, 2 to 10 VDC
Options							3V	3-way valve
							AT	Aluminum tag
							FC	Factory calibration certificate
							LCD	LCD indication
							NIST	NIST traceable certificate

\*Pressures exceeding the working pressure limit may cause a calibration shift of up to ±3% of full scale.

## INSTALLATION

**1. Location:** Select a location where the temperature of the unit will be between 0 and 200°F (-18 to 93°C). Distance from the receiver is limited only by total loop resistance (see electrical connections). The tubing feeding pressure to the instrument can be practically any length required, but long lengths will increase the response time slightly. Mount the instrument in a location that will not be subject to excessive temperature, shock, or vibration.

**2. Position:** A vertical position is recommended (pressure connections pointing horizontally) since that is how all standard models are spanned and zeroed at the factory. They can be used at other angles, but may require final zeroing. Due to potential condensation buildup that may travel down conduit or cable and into the housing, it is recommended to install with the electrical conduit or cable gland pointing downward.

**3. Pressure Connection:** Dual 1/4" NPT pressure connections are provided. Use pipe thread sealant tape or other suitable pipe joint compound when making connection to the pressure source. Avoid excess sealant which could block the pressure passage. When monitoring liquid pressures, air trapped in the lines can cause incorrect readings. Bleed fittings or similar mechanisms should be used to bleed off any trapped air.

## Optional 3-Way Valve

For applications where higher line pressures may be encountered at installation or when it is necessary to remove the transmitter for maintenance without interrupting the process, the optional three way valve is recommended. (See Figure 1)

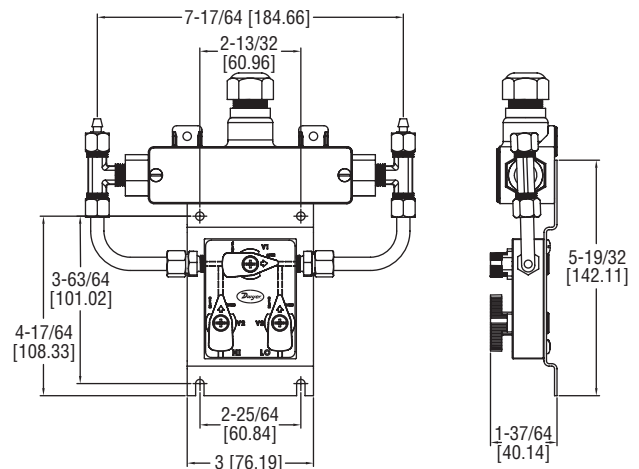


Figure 1: 629C with Optional 3-Way Valve

Installation with 3-way valve option. Begin with valve V1 open and valves V2 and V3 closed. (See Figure 2) Slowly open valves V2 and V3. Once the pressure has stabilized and is equal on the high and low side of the transmitter, valve V1 can be closed and normal operation can proceed.

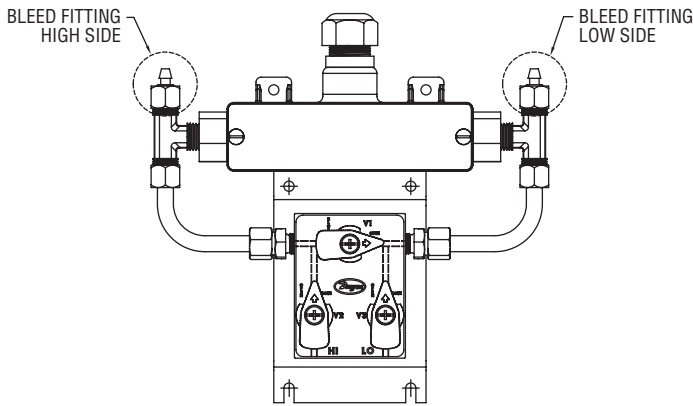


Figure 2: Bleed Fitting Connections

To ensure proper pressures will be detected by the 629C, use the bleed fittings provided with this package to free media of bubbles. Before applying pressure to the process connections, turn V1 to the open position and back off either the low or high side bleed hex nut. Next, apply pressure. After the flowing liquid is free of bubbles, retighten the bleed hex nut.

Before removing the transmitter from operation, open valve V1, then close valves V2 and V3.

**Optional Remote Sensor Installation**

For both shielded cable and armored cable versions of remote sensors option, follow standard installation procedures.

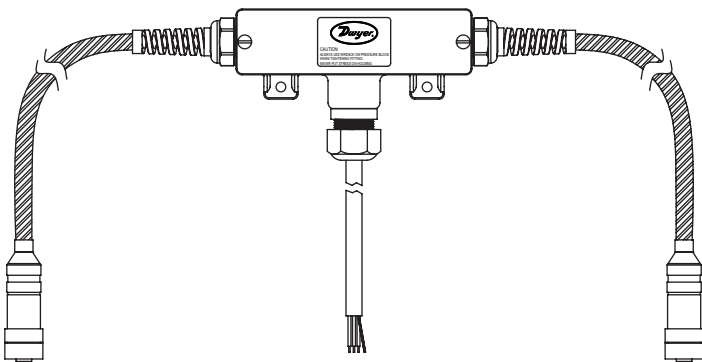


Figure 3: 629C with Remote Sensor

Install the high and low remote sensors in respective locations in the process. Use of thread sealant is recommended to prevent leaks. During installation, care must be taken to ensure that the serial number on the sensor matches the serial number on the transmitter housing. Additionally, a check must be made to ensure that the check box for high or low pressure on the sensor matches the check box for high or low pressure on the cable tag. The sensor with a mark in the "High Pressure" box should be connected to the higher pressure, and the sensor with a mark in the "Low Pressure" box should be connected to the lower pressure in order to ensure accurate readings. The vent hole on the side of the unit should not be covered by anything aside from the fiber filter installed from the factory. Do not remove the fiber filter installed over the vent hole.

After sensor installation, attach the cable to the sensor by means of the M-12 connector shown in Figure 4. The cables connecting the sensors to the transmitter housing can only be disconnected at the sensor by means of the M-12 connectors. No attempt should be made to disconnect remote cables at the transmitter housing.

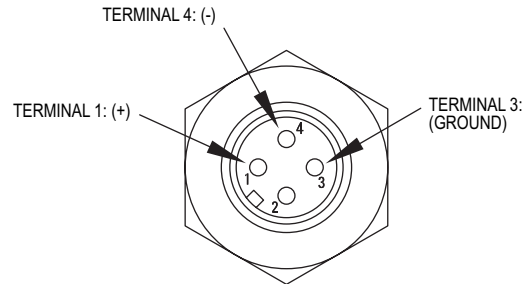


Figure 4: M-12 Connector

For applications where differential pressure is measured at high line pressure, it is recommended to install pressure sensor with a valve in each line and a shunt valve across the high and low pressure ports (see Figure 5).

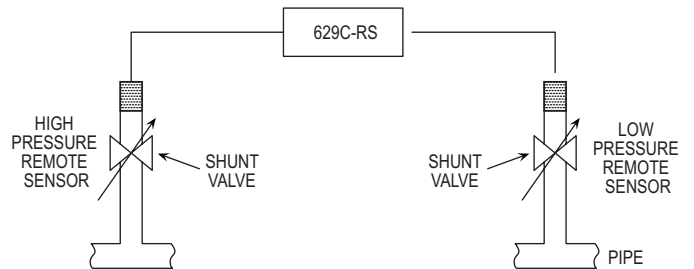


Figure 5: Sensor Installation with Valves

**ELECTRICAL CONNECTIONS**

Shielded cable is recommended for control loop wiring. Electrical connections to the Series 629C pressure transmitters are made to the terminal block located inside the housing. Remove the screws and lift off the cover. Wire as shown in Figure 6 or 7. Use Figure 6 for current output connection. Use Figure 7 for current output with optional LCD display. If ordering pre-wired cable, black wire is negative (-) and red wire is positive (+).

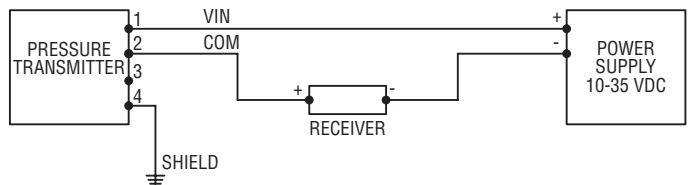
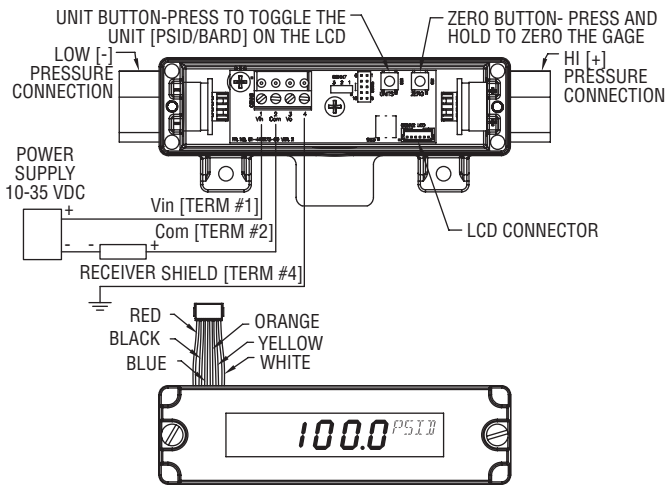


Figure 6: Current Output Connection



**TRANSMITTER CONNECTION INSTRUCTION:**

- TURN OFF POWER SUPPLY.
- CONNECT THE POWER SUPPLY AND RECEIVER TO Vin [TERM #1] AND Com [TERM #2] OF THE GAGE AS SHOWN.
- INSTALL THE LCD'S CONNECTOR TO THE GAGE AS SHOWN.
- TURN ON POWER.

**CAUTION:** BE SURE TO TURN OFF POWER WHEN CONNECTING OR REMOVING THE LCD CONNECTOR. FAILURE TO DO SO CAN RESULT IN GAGE DAMAGE.

**Figure 7: Current Output with Optional LCD**

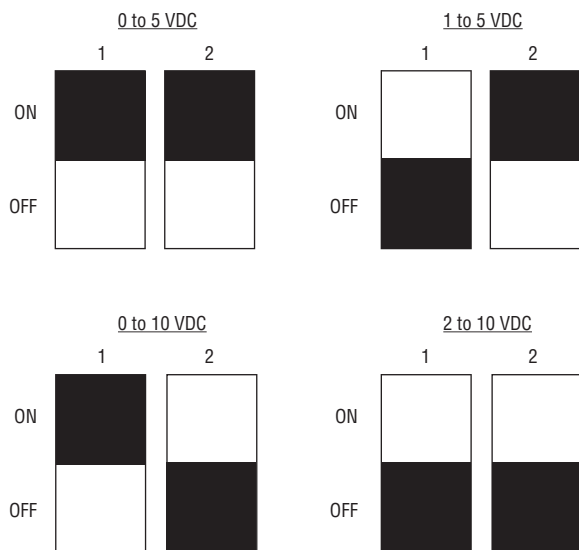
**Wire Length** – The maximum length of wire connecting transmitter and receiver is a function of wire size and receiver resistance. Wiring should not contribute to more than 10% of receiver resistance to total loop resistance. For extremely long runs (over 1000 ft or 305 m), choose receivers with higher resistance to minimize size and cost of connecting leads. When wiring length is under 100 ft (30.5 m), lead wire as small as 22 AWG can be used.

**Current (4 to 20 mA) Output Operation** – An external power supply delivering 10 to 35 VDC with minimum current capability of 40 mA DC (per transmitter) is required to power the control loop. See Figure 9 for connection of the power supply, transmitter, and receiver. The range of the appropriate receiver load resistance (RL) for the DC power supply voltage available is expressed by the formula

$$R_L \text{ max} = \frac{vps - 10}{20 \text{ mA DC}}$$

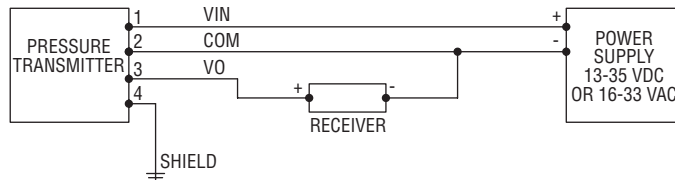
**VOLTAGE (0 TO 5, 1 TO 5, 0 TO 10, OR 2 TO 10 V) OUTPUT OPERATION**

To select the voltage output that is going to be used, configure the dip switches according to the Figure 8 below. Power must be cycled whenever dip switches are changed to select output.

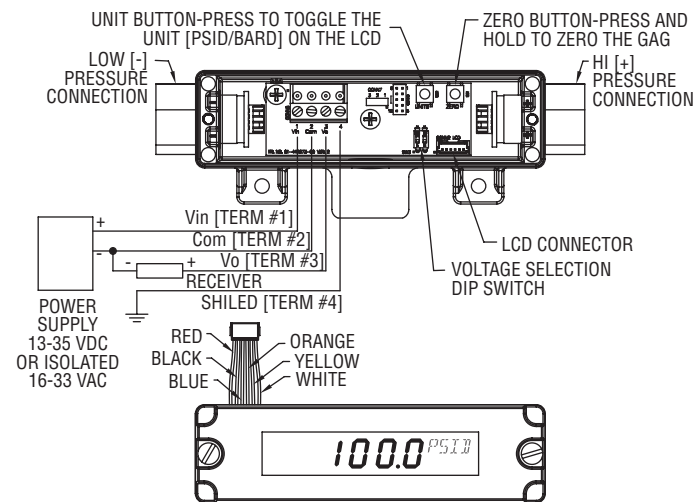


**Figure 8: Voltage Output Dip Switch Selection**

For voltage outputs, wire as shown in Figure 9 for voltage output connection. Use Figure 10 for voltage output with optional LCD display. Terminal 1 is positive (+), terminal 2 is negative (-), and terminal 3 is +Vout. If ordering optional prewired cable, black wire is negative (-), red wire is positive (+), and white wire is +Vout. For optimal accuracy, use a separate common wire for the receiver.



**Figure 9: Voltage Output Connection**



**TRANSMITTER CONNECTION INSTRUCTION:**

- TURN OFF POWER SUPPLY.
- CONNECT THE POWER SUPPLY [+] TO Vin [TERM #1] AND [-] TO Com [TERM #2] OF THE GAGE AS SHOWN.
- CONNECT THE RECEIVER [+] TO Vo [TERM #3] OF THE GAGE AND RECEIVER [-] TO POWER SUPPLY [-].
- INSTALL THE LCD'S CONNECTOR TO THE GAGE AS SHOWN.
- SET VOLTAGE SELECTION DIP SWITCH TO DESIRED VOLTAGE OUTPUT.
- TURN ON POWER.

**CAUTION:** BE SURE TO TURN OFF POWER WHEN CONNECTING OR REMOVING THE LCD CONNECTOR. FAILURE TO DO SO CAN RESULT IN GAGE DAMAGE.

**Figure 10: Voltage Output with Optional LCD Display**

**MAINTENANCE/REPAIR**

Upon final installation of the Series 629C Wet/Wet Differential Pressure Transmitter, no routine maintenance is required. The Series 629C is not field serviceable and is not possible to repair the unit. Field repair should not be attempted and may void warranty.

**WARRANTY/RETURN**

Refer to "Terms and Conditions of Sale" in our catalog and on our website. Contact customer service to receive a Return Material Authorization number before shipping the product back for repair. Be sure to include a brief description of the problem plus any additional application notes.