

455 SERIES

3-Phase Voltage/Phase Monitor

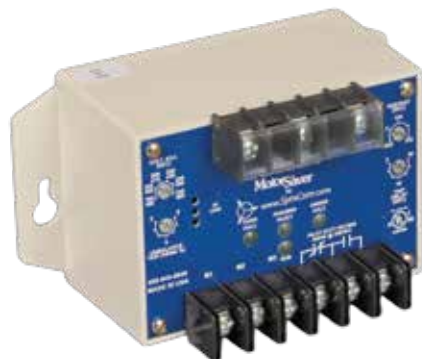

Wiring Diagram

MODEL 455 WITH MOTOR CONTROL USING A 3-POLE CONTACTOR

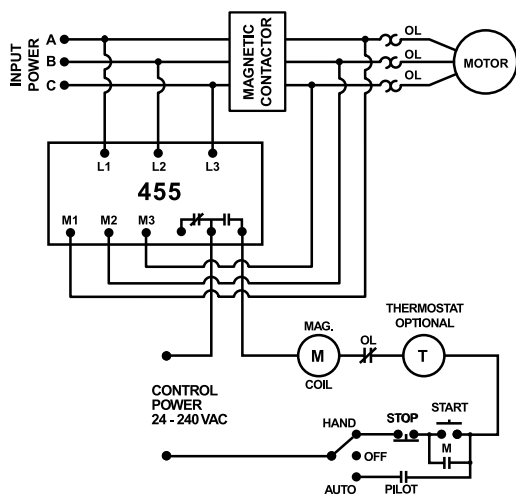

MODEL 455 WITH MOTOR CONTROL USING A 2-POLE CONTACTOR

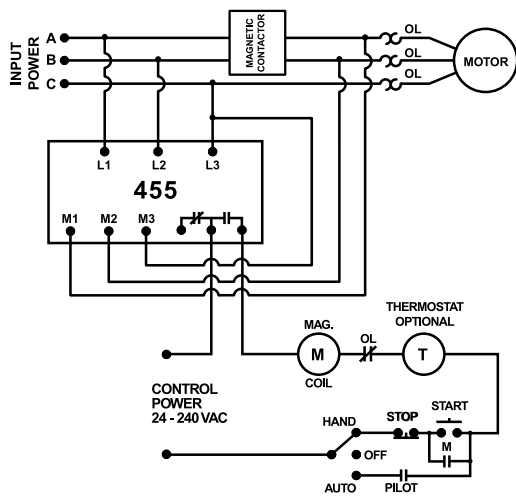

Description

The 455 Series are 3-phase voltage monitors that combine load and line side monitoring to offer complete protection. Monitoring the load side will alert the user of contactor failure or impending contactor failure. Line side monitoring will also protect the motor from damaging fault conditions that may be present prior to the motor starting. With other line/load side monitors, the motor must be started before a voltage fault is detected. With the 455, your motor is fully protected at all times.

The 455 Series are 3-phase, dual range voltage monitors that protect 190-480VAC, 50*/60Hz motors, regardless of their size. It automatically selects between the 200V and 400V range when the user selects the nominal voltage setpoint. Other adjustments include a 2-30 second trip delay, a 2-300 second restart delay (and manual restart) and a voltage unbalance trip point of 2-8%. The voltage monitor's circuitry is powered through the line side connections, so there is no need for separate control power, making it easy to install.

Equipped with an infrared LED, the 455 Series can communicate to the optional hand-held diagnostic tool, Informer-MS to obtain valuable information such as real-time voltage, voltage unbalance on both line and load sides, motor run hours, last 20 faults, last 32 motor starts, high and low voltage trip points, voltage unbalance trip point, restart and trip delay settings, LED status and more.

Features & Benefits

| FEATURES | BENEFITS |
|--|--|
| Load side monitoring of contactor | Protects motor from contactor failure or worn contacts. |
| Monitors contactor or starter | Prevents rapid cycling |
| Infrared LED Capable | Increases personnel safety line of sight monitoring using optional Informer-MS |

Accessories



Informer-MS

A hand-held diagnostic tool designed for use with Littelfuse® 455 equipped with an infrared LED transmitter



Informer IR Kit-36

36" infrared adapter cable attaches to the face of the unit to provide remote diagnostics without opening the panel.

Ordering Information

| MODEL | LINE VOLTAGE | DESCRIPTION |
|---------|--------------|---|
| 455 | 190-480VAC | Universal line and load side monitor |
| 455480R | 380-480VAC | Used in high voltage applications with pilot duty 470VA @ 600VAC |
| 455575 | 475-600VAC | For use in Canada or NE USA where 575V utility power services are common. |

For dimensional drawing see: Appendix page 509, Figure 6.

455 SERIES

Specifications

| | |
|---|----------------------------|
| Frequency | 50*/60Hz |
| Low Voltage (% of setpoint) | |
| Trip | 90% ±1% |
| Reset | 93% ±1% |
| High Voltage (% of setpoint) | |
| Trip | 110% ±1% |
| Reset | 107% ±1% |
| Voltage Unbalance (NEMA) | |
| Trip | 2-8% adjustable |
| Reset | Trip setting minus 1% |
| Trip Delay Time | |
| Low & High Voltage and Unbalance | 2-30 seconds adjustable |
| Single-phasing Faults (>25% UB) | 2 seconds fixed |
| Restart Delay Time | |
| After a Fault | Manual, 2-300 seconds adj. |
| After a Complete Power Loss | Manual, 2-300 seconds adj. |
| After a Motor Shut-down | Manual, 2-300 seconds adj. |
| Output Characteristics | |
| Output Contact Rating (SPDT) | |
| Pilot Duty | 480VA @ 240VAC |
| General Purpose | 10A |
| High Voltage Relay (-480R) | |
| Pilot Duty | 470VA @ 600VAC |

General Characteristics

| | |
|--|--|
| Ambient Temperature Range | |
| Operating | -40° to 70°C (-40° to 158°F) |
| Storage | -40° to 80°C (-40° to 176°F) |
| Repeat Accuracy | |
| Fixed Conditions | ±0.1% |
| Maximum Input Power | 6 W |
| Terminal | |
| Torque | 7 in.-lbs. |
| Wire Size | 12-18AWG |
| Transient Protection (Internal) | IEC 61000-4-5;1995 ±6kV |
| Safety Marks | |
| UL | UL508 (File #E68520) |
| CSA | C22.2 No. 14 (File #46510) |
| CE | IEC 60947-6-2 |
| Dimensions | H 74.4 mm (2.93"); W 133.9 mm (5.27"); D 74.9 mm (2.95") |
| Weight | 1.1 lbs. (17.6 oz., 498.95 g) |
| Mounting Method | #8 screws |

*Note: 50Hz will increase all delay times by 20%.