

A28MA Type Two-Stage Tower Fan Control Two-Stage Air Cooled Condenser Fan Control

Application

The A28MA temperature controls are designed to maintain optimum head pressure on refrigeration and air conditioning installations by controlling the operation of two-speed fan motors or dual fans. The fan motor operation is controlled by temperature change at the sensing bulb. Two basic constructions are available.

- *For Cooling Towers or Evaporative Condensers* -- The A28MA-1 and -4 controls with Neoprene coated bulb and capillary are for sump water temperature control. The coated element resists mechanical abrasion and chemical damage.

- *For Air Cooled Condensers* -- The A28MA-2 and -3 controls with tin plated bulb and capillary are for clamp-on application to the condenser or liquid line.

The A28MA controls have two SPDT switches for flexibility of application shown in Figs. 4 and 5. The operating sequence of the two switches cycled by a single temperature sensing element cannot be altered in the field. The single dial adjustment moves both high stage and low stage settings by a like amount.

All Series A28 temperature controls are designed for use only as operating controls. Where an operating control failure would result in personal injury and/or loss of property,



Fig. 1: An A28MA-1 Cooling Tower Fan Control.

it is the responsibility of the installer to add devices (safety, limit controls) or systems (alarm, supervisory systems) that protect against, or warn of, control failure.

Features

- Weather resistant gasketed enclosure has gray UL Listed outdoor finish.
- Liquid-filled sensing element is unaffected by barometric pressure and cross ambient temperatures.
- Strain-free mounting on three rubber cushioned mounting feet.

Specifications

Product Number	A28MA-1	40 to 120°F Range Plate, Neoprene Coated Bulb and Capillary, for Cooling Tower or Evaporative Condensers
	A28MA-2	40 to 120°F Range Plate, Tin Plated Bulb and Capillary, for Air Cooled Condensers
	A28MA-3	5 to 50°C Range Plate, Tin Plated Bulb and Capillary, for Air Cooled Condensers
	A28MA-4	5 to 50°C Range Plate, Neoprene Coated Bulb and Capillary, for Cooling Tower or Evaporative Condensers
Differential (Fixed)	Each Stage	5F° (2.8C°)
	Between Stages	8F° (4.4C°)
Maximum Bulb Temperature	210°F (99°C), Overrun At Infrequent Intervals	
Switches	Two SPDT Pennswitches With Snap-Acting Contacts In Dust Protected Enclosure	
Sensing Element	3/8" (9.5 mm) x 4" (102 mm) Bulb With 6 foot (1.8 m) Capillary	
Range Adjuster	Internal Screwdriver Slot and Dial	
Wiring Connections	Screw Type Terminals	
Enclosure	Rainproof With Gasketed Cover (NEMA 3R)	
Finish	UL Listed Outdoor Gray Enamel	
Material	.062" (1.6 mm) Cold Drawn Steel	
Mounting	Three Rubber Cushioned Mounting Feet	
Conduit Opening	Welded 3/4" Female Connector	
Shipping Weight	2.3 lb (1.0 kg)	

©Copyright 1988 Johnson Controls, Inc.
All rights reserved.

© 2016 Johnson Controls, Inc.
Code No. LIT-125135
Part No. 3534, Rev. E

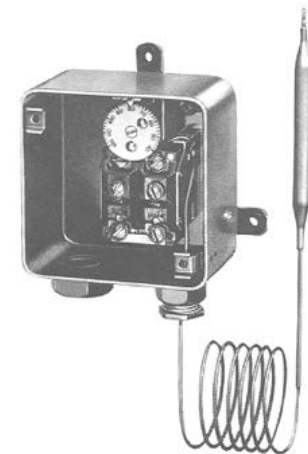

Fig. 2: An A28MA Control with the cover removed.

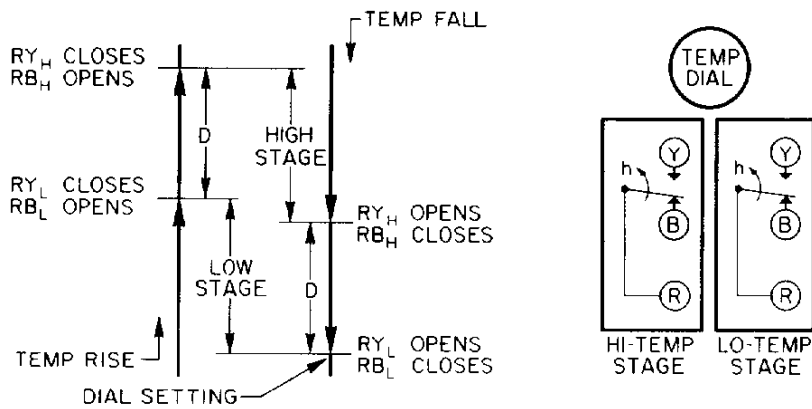

Fig. 3: Switching action of the two-stage control is illustrated above. RB_H, RY_H indicates HI-TEMP stage; RBL, RYL indicates LO-TEMP stage. "D" represents the differential between stages.

When the A28MA is mounted indoors, it may be mounted in any position with screws or bolts through the rubber bushings in the three mounting feet. When the A28MA will be exposed directly to the outdoor weather, the control should be mounted with the electrical connection and capillary fitting facing downward as shown in Fig. 1.

CAUTION: Do not dent or deform the sensitive bulb of this control. A dent or deformation will change the calibration and cause the control to cycle at a temperature lower than the dial setting.

General Description

The A28MA controls have two enclosed SPDT switches. The red terminal is common. When the red to blue terminals are wired, the circuit opens on a temperature increase. (See Fig. 3.) When the red to yellow terminals are wired, the circuit closes on a temperature increase. The switch differential and between stage differential are fixed.

Accessories

A bulb well is available for use with the tin plated sensing bulb, if required. Specify Part No. WEL 14A-602R.

Ordering Information

To order specify Product Number only.

Installation

CAUTION: To avoid possible electrical shock or damage to the equipment, disconnect the power supply before wiring and mounting connections are made.

Use terminal screws furnished (8-32 x 1/4 in. binder head). Substitution of other screws may cause problems in making proper connections.

Adjustment

The temperature set point may be changed to meet the requirements of the installation. Remove the cover to change the set point. Using a screwdriver, rotate the dial to the desired set point.

Checkout Procedure

Before leaving the installation, observe at least three complete operating cycles to be sure that all components are functioning correctly.

Repairs and Replacement

Field repairs must not be made. For a replacement control, contact the nearest Johnson Controls wholesaler.

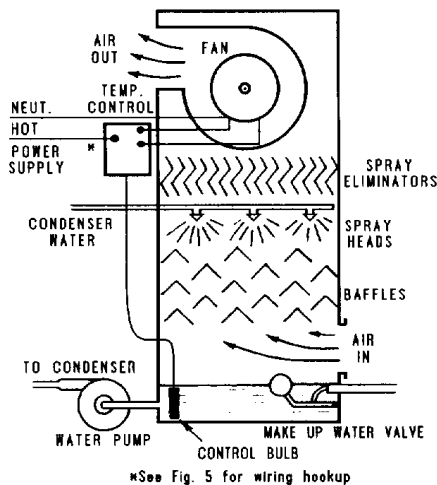
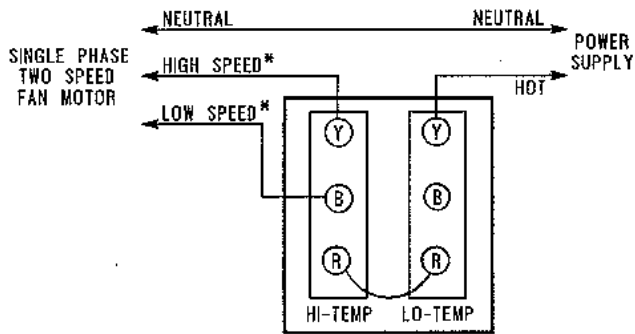

Fig 4: Wiring hookup and installation of the A28MA-1 Cooling Tower Fan Control with a forced draft cooling tower.

Electrical Ratings

Voltage, AC	120	208	240	277
Full Load Amp	16.0	9.2	8.0	—
Locked Rotor Amp	96.0	55.2	48.0	—
Non-Inductive or Resistance Load Amp (Not Lamp Loads)	16.0	9.2	8.0	7.2
Pilot Duty — 125 VA, 24/277 VAC				

NOTE: When used as a two circuit switch, the total connected load must not exceed 2000 VA and must have a common return.



*May be starter "pull coils" on two-speed polyphase motors.

Fig. 5 — Typical wiring hookup for two-speed fan motors provides high speed, low speed and "Off" control.

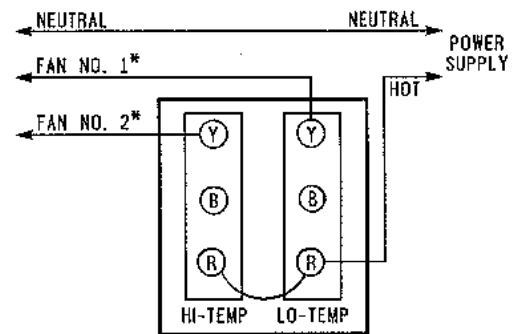

*May be starter "pull coils" on two-speed polyphase motors or motors in excess of control rating.

Fig. 6 — Typical wiring hookup for two fan control provides dual fan, single fan and "Off" control.

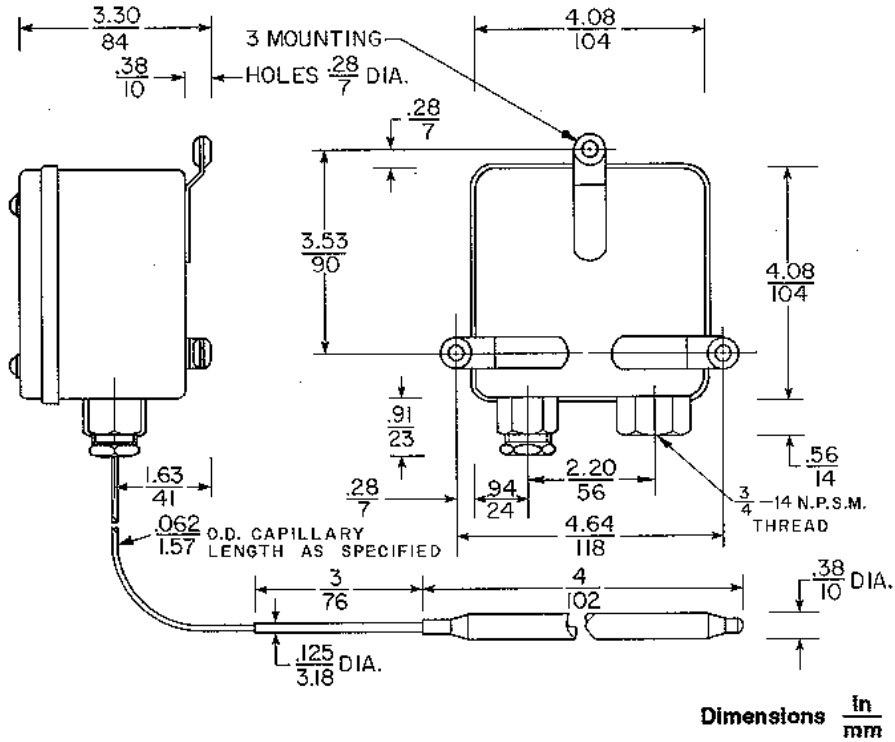

Performance specifications appearing herein are nominal and are subject to accepted manufacturing tolerances and application variables.

Notes

European Single Point of Contact:

JOHNSON CONTROLS
WESTENDHOF 3
45143 ESSEN
GERMANY

NA/SA Single Point of Contact:

JOHNSON CONTROLS
507 E MICHIGAN ST
MILWAUKEE WI 53202
USA

APAC Single Point of Contact:

JOHNSON CONTROLS
C/O CONTROLS PRODUCT MANAGEMENT
NO. 22 BLOCK D NEW DISTRICT
WUXI JIANGSU PROVINCE 214142
CHINA



Controls Group

507 E. Michigan Street
P.O. Box 423
Milwaukee, WI 53202

Printed in U.S.A.