

System 350™ A350R Electronic Temperature Reset Control (with Relay)

The A350R Electronic Temperature Reset Control is designed to raise or lower the setpoint of supply water temperature based upon a proportionate drop or rise in temperature at the master (outdoor) sensor. The control output is a Single-Pole, Single-Throw (SPST) relay with Light-Emitting Diode (LED) relay status indication.

The A350R's differential may be adjusted for a given application. An adjustable reset ratio adapts to a variety of weather zones and to the specific heat loss characteristics of most buildings.

As are all System 350™ products, the A350R is housed in a NEMA 1, high-impact plastic enclosure. The modular design provides easy, plug-together connections for quick installation and future expandability.



Figure 1: A350R Electronic Temperature Reset Control

Features and Benefits	
<input type="checkbox"/> Modular Design	Enables stage, display, and transformer modules to be purchased and installed as necessary
<input type="checkbox"/> Adjustable Master Reset Setpoint (M.R.S.)	Enables the user to select a master (outdoor) sensor temperature starting point for the supply reset ramp
<input type="checkbox"/> Adjustable Minimum and Maximum Supply Temperature	Permits compliance with equipment manufacturer's specifications
<input type="checkbox"/> Selectable Warm Weather Shutdown Temperature	Saves energy by disabling equipment when master sensor temperature rises to a point where heating is no longer required
<input type="checkbox"/> Adjustable Setback Temperature	Saves energy by lowering the supply temperature setpoint at night or during unoccupied periods

Application

The A350R Electronic Temperature Reset Control can be used as a standalone device or in conjunction with plug-together accessory modules. The addition of an S350A or S350C for on/off output, or an S350P for a proportional or proportional plus integral control, allows this system to control a variety of single or multiple stage Heating, Ventilation, and Air Conditioning (HVAC) applications. Typical applications include reset of single or multistage boilers.

Operation

IMPORTANT: Use this A350R Electronic Temperature Reset Control (with Relay) only as an operating control. Where failure or malfunction of the reset module could lead to personal injury or property damage to the controlled equipment or other property, additional precautions must be designed into the control system. Incorporate and maintain other devices, such as supervisory or alarm systems or safety or limit controls, intended to warn of or protect against failure or malfunction of the reset module.

IMPORTANT: Utiliser ce A350R Electronic Temperature Reset Control (with Relay) uniquement en tant que dispositif de contrôle de fonctionnement. Lorsqu'une défaillance ou un dysfonctionnement du reset module risque de provoquer des blessures ou d'endommager l'équipement contrôlé ou un autre équipement, la conception du système de contrôle doit intégrer des dispositifs de protection supplémentaires. Veiller dans ce cas à intégrer de façon permanente d'autres dispositifs, tels que des systèmes de supervision ou d'alarme, ou des dispositifs de sécurité ou de limitation, ayant une fonction d'avertissement ou de protection en cas de défaillance ou de dysfonctionnement du reset module.

The A350R operates on 24 VAC/VDC and provides a Single-Pole, Single-Throw relay output. A front panel

LED lights to indicate the relay is energized. Features include:

- adjustable reset ratio
- adjustable master reset setpoint
- adjustable minimum and maximum supply temperature
- adjustable differential
- selectable relay for Minimum ON Time
- selectable warm weather shutdown temperature
- adjustable setback temperature

Celsius Scale Conversion

As shipped from the factory, each A350R is installed with the Fahrenheit temperature scale decal. A Celsius temperature scale decal is provided under the cover of the A350R. If the Celsius scale is desired, see the *Installation and Wiring* section.

Reset Ratio Adjustment

Reset ratio is defined as the ratio of the change in master sensor temperature to the change in supply temperature setpoint. Example: For an application with a reset ratio of 1:2, a one degree drop in master sensor (for example, outdoor air) temperature causes a two degree rise in the supply temperature setpoint. Refer to Figure 2 for an example.

Reset ratio adjustment is made using the potentiometer marked RESET RATIO. Refer to Figure 4 for location.

Minimum Supply Temperature and Master Reset Setpoint Adjustments

The minimum supply temperature and the master reset setpoint adjustments determine the starting point for the reset ramp. As the master (outdoor) sensor temperature falls below the master reset setpoint, the supply setpoint rises according to the reset ratio. As the master sensor temperature rises above the master reset setpoint, the supply setpoint will be maintained at the minimum supply temperature. Refer to Figure 2 for an example.

Minimum supply temperature adjustment is made using the potentiometer marked MIN SUPPLY, and master reset setpoint adjustment is made using the potentiometer marked M.R.S. Refer to Figure 4 for locations.

Maximum Supply Temperature Adjustment

The maximum supply adjustment determines an end point for the reset ramp. Refer to Figure 2 for an example.

As the master sensor temperature drops below the master reset setpoint, the supply setpoint temperature rises according to the reset ratio. Upon further reduction in master sensor temperature, the supply setpoint temperature continues to rise until it reaches the maximum supply temperature setpoint. The supply temperature is maintained at the maximum supply temperature setpoint even on a further decrease in master sensor temperature. Use the formula found in *Adjustments* section to determine the reset ratio.

Maximum supply temperature adjustment is made using the potentiometer marked MAX SUPPLY. Refer to Figure 4 for location.

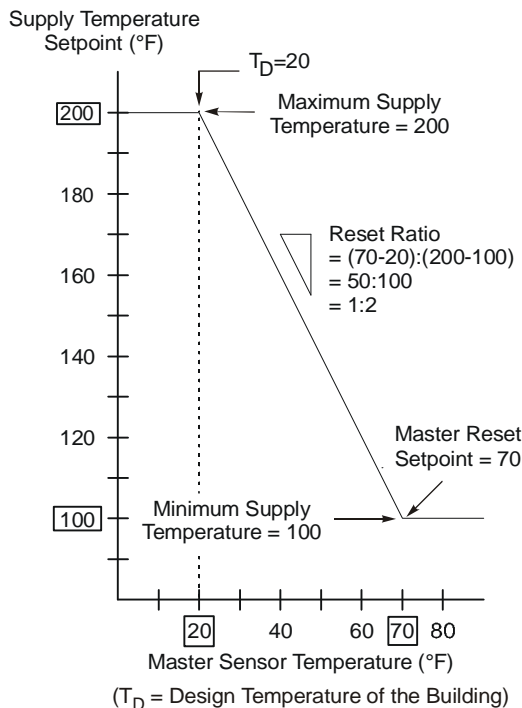

Figure 2: Example of Reset Schedule for a Hot Water Boiler Application

Differential Adjustment

Differential is the change in supply temperature required to energize and to de-energize the relay. Figure 3 is an example.

The differential can be adjusted between 1 and 30°F (0.5 to 17°C). Adjustment is made using the potentiometer marked DIFF, as shown in Figure 4.

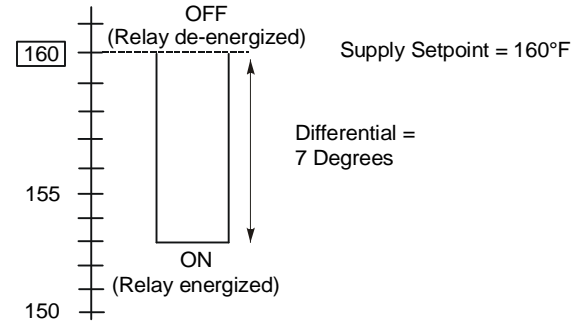

Figure 3: Example of Differential

Minimum Relay ON Time Selection

In addition to the differential, the relay operation is also affected by the selectable Minimum ON Time delay. Once the relay is energized, it remains energized until both the Minimum ON time has expired, and the supply temperature is equal to or greater than the calculated setpoint. The time delay applies only to the relay internal to the A350R. A jumper block, located on the cover mounted circuit board (refer to Figure 4), is used to select one of four minimum ON time delay settings: OFF, 1 min., 2 min., or 3 min.

Warm Weather Shutdown Temperature Selection

The A350R has a feature that automatically shuts down the heating equipment when the master sensor temperature rises to a value where heating is no longer desired. When the master sensor drops 3°F (1.7°C) below the warm weather setpoint temperature, the A350R returns to standard operation.

A jumper block located on the base-mounted circuit board is used to select one of five shutdown settings. (Refer to Figure 4.) Available settings are OFF, 60°, 64°, 68°, and 72°F (OFF, 16°, 18°, 20°, and 22°C). Placing the jumper block horizontally across the center set of pins (OFF position) disables warm weather shutdown. As shipped from the factory, the warm weather shutdown feature is set to the OFF position.

IMPORTANT: Do not place the jumper across the top or bottom two pins. This disables the warm weather shutdown, and causes a small shift in the maximum supply setpoint and the master reset setpoint.

Setback Adjustment

The A350R has an integral setback feature which, when enabled, lowers the calculated supply setpoint by the setback value. This calculated supply setpoint will not go below the Minimum Supply Temperature setting.

Setback is enabled by an external time clock switch that shorts terminals IN and COM together. The CLK350 Time Control, which is compatible with the A350R, requires a 24 VAC source. Other external time controls may be used with the A350R, but they must have a minimum switch rating of 5 mA at 5 VDC.

When enabled, the Setback LED on the face of the A350R illuminates to indicate the control is operating in the setback mode. Setback is adjustable from 0 to 30F° (0 to 17C°) via the setback potentiometer located at the top of the cover-mounted circuit board. See Figure 4 for its location.

Add-on Modules

The S350 Stage Modules, D350 Digital Temperature Display Module, and Y350R Power Module connect together and plug into the A350R via female connectors located on the left side and male connectors located on the right side of each module. The maximum number of add-on modules is listed in Table 1.

Table 1: Maximum Number of S350 Stage Modules per A350R

Power Source	Number of S350A or S350C Modules Allowed	Number of S350A or S350C Modules (with 1 S350P) Allowed	Number of S350A or S350C Modules (with 2 S350Ps) Allowed
Y350R	9	6	4
External Class 2 Transformer	9	8	7

Note: For each S350P added, the number of S350A or S350C Stage Modules that can be used with a Y350R decreases by two. If an external transformer is used, the number of S350A and S350C Stage Modules used decreases by one for each additional S350P.

S350A On-Off Stage Modules

S350A On-Off Stage Modules receive power, setpoint, and sensor input from the A350R Reset Control. The S350A Stage Modules perform switching functions based on the A350R's calculated supply setpoint and supply sensor temperature, but the offset and differential are selected within the S350A.

Note: Plug the S350A only into the right side of the A350R. The S350A will not function properly if plugged into the left side of the A350R.

For more information on these modules, refer to *System 350™ S350 Temperature, S351 Humidity, and S352 Pressure On/Off Stage Modules Product/Technical Bulletin (LIT-930080)*.

S350C Slave Stage Modules

S350C Slave Stage Modules receive power, and sensor input from the A350R Reset Control. S350C Slave Stage Modules perform switching functions based on the setpoint and differential selected at the S350C.

Note: Unlike the S350A, the S350C can plug into either side of the A350R. When the S350C is plugged into the **left** side of the A350R, it controls to the S350C setpoint based on the master sensor temperature input. When the S350C is plugged into the **right** side of the A350R, it controls to the S350C setpoint based on the supply sensor temperature.

For more information on these modules, refer to *System 350™ S350C Temperature Slave Stage Module Product/Technical Bulletin (LIT-930084)*.

S350P Proportional Stage Modules

S350P Proportional Stage Modules receive power, setpoint, and sensor input from the A350R Reset Control. The S350P Proportional Stage Module responds with an analog 0 to 10 VDC and 0 to 20 mA output signal based on the A350R's calculated supply setpoint and sensor temperature, as well as the offset and throttling range selected at the S350P.

Note: Plug the S350P only into the **right** side of the A350R. The S350P will not function properly if plugged into the left side of the control.

For more information on these modules, refer to *System 350™ S350P Proportional Plus Integral Temperature Stage Module Product/Technical Bulletin (LIT-930086)*.

D350 Temperature Display Module

The D350 receives its power, sensor, and setpoint information from the A350R. Depending on which side of the A350R the D350 is connected, various sensor and setpoint information is available.

When the D350 is plugged into the **left** side of the A350R, it continuously displays the master sensor temperature. When the PRESS FOR SETPOINT button is pressed, the A350R's supply sensor temperature is displayed.

When the D350 is plugged into the **right** side of the A350R, it continuously displays the supply sensor temperature. When the PRESS FOR SETPOINT button is pressed, the A350R's supply setpoint is displayed.

For more information on this module, refer to *System 350™ Display Modules Product/Technical Bulletin (LIT-930070)*.

Y350R Power Module

The Y350R provides a convenient method of powering System 350 modules from a 120 or 240 VAC power source. The Y350R can be plugged into either the right (preferred location) or left side of the A350R control or any of the accessory modules.

For more information on this module, refer to *System 350™ Y350R Power Module Product/Technical Bulletin (LIT-930090)*.

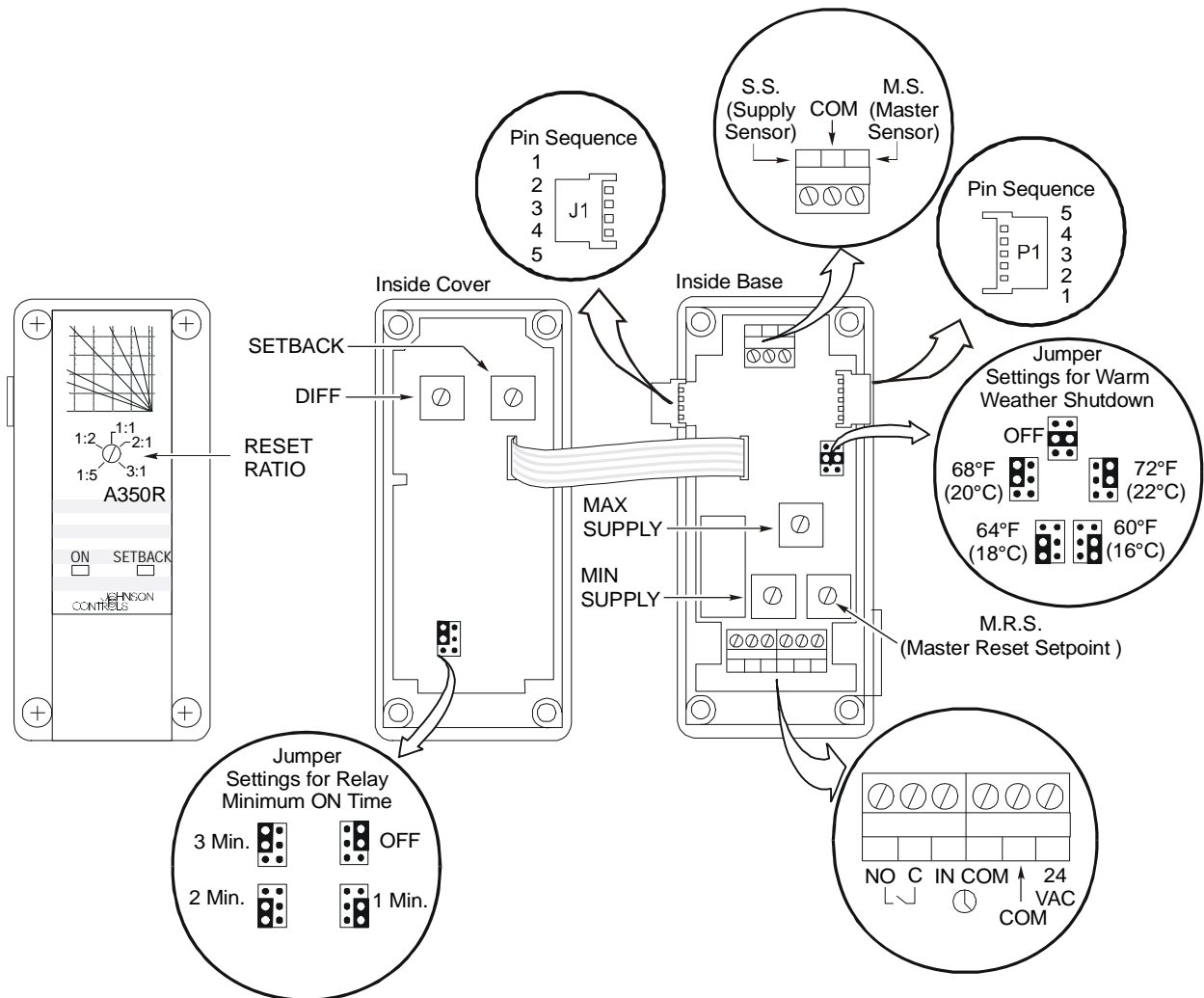

Figure 4: A350R Features

Dimensions

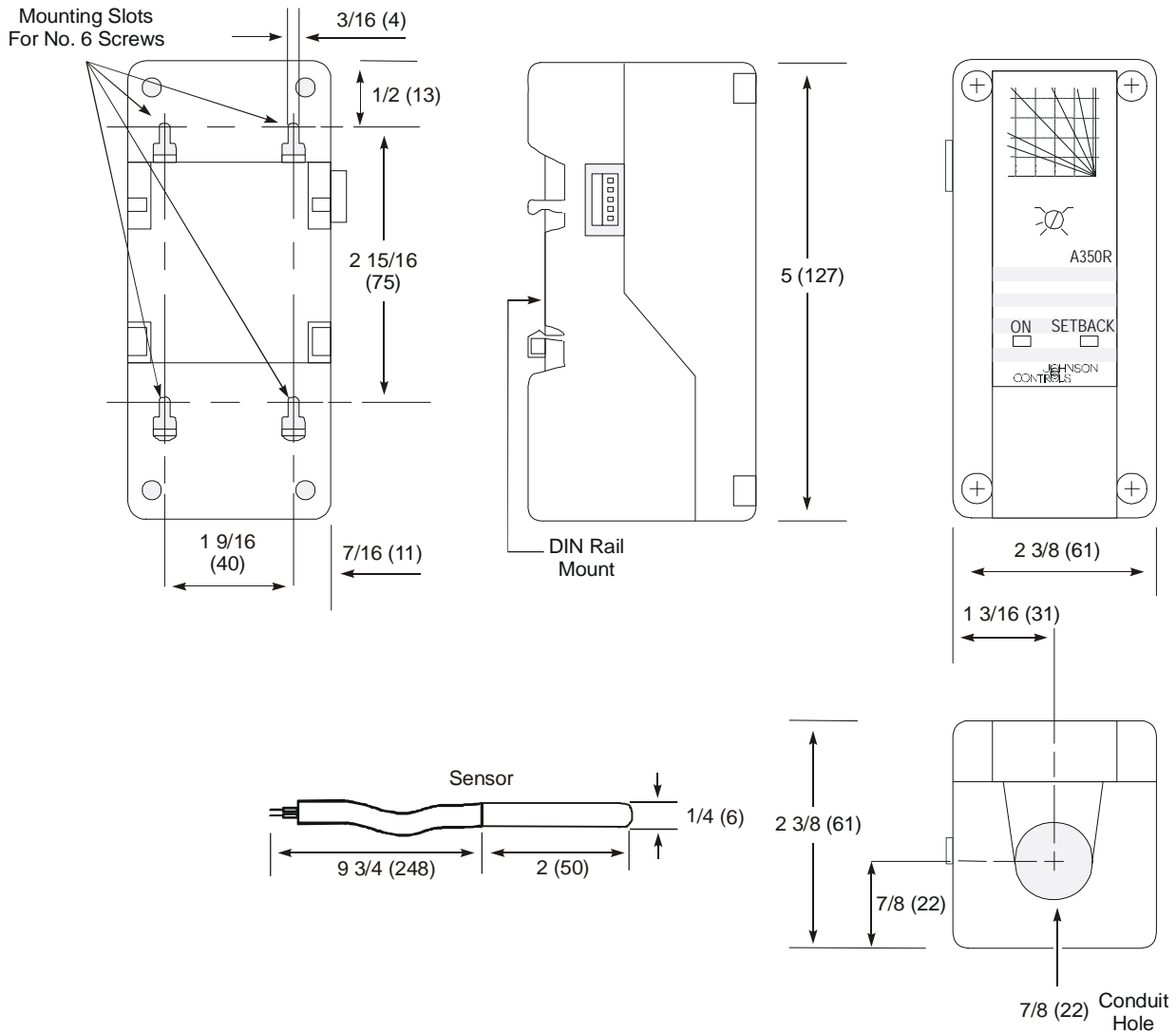

Figure 5: A350R and Sensor Dimensions, in. (mm)

/Installation and Wiring

Celsius Scale Conversion

As shipped from the factory, the five potentiometers located on the circuit board have Fahrenheit scale decals installed. Celsius temperature scale decals are provided in a small envelope under the cover of the A350R. To replace the Fahrenheit decals with the Celsius decals:

1. Carefully remove the red knobs on each potentiometer.
2. Peel off the existing Fahrenheit scale decals.
3. Apply the Celsius scales where the Fahrenheit scales were located previously.
4. Rotate all five knob stems completely counterclockwise.
5. Reinstall the potentiometer knobs so the arrows point to the minimum scale temperature.

Mounting the A350R

The A350R Reset Control is housed in a compact NEMA 1 plastic enclosure designed for standard 35 mm DIN rail mounting. It should be mounted for convenient wiring and adjustment. Four key-slot mounting holes on the back of the control case are provided should surface mounting be required. If a Y350R is used, it should be mounted immediately to the right of the A350R. Any S350 controls would follow on the right, with the D350 being the last control mounted. (D350 and S350C controls may also be mounted to the left of the A350R.)

Note: When mounting the A350R (or any System 350 module) to rigid conduit, attach the hub to the conduit before securing the hub to the control enclosure.



CAUTION: Risk of Electrical Shock.

Disconnect the power supply before making electrical connections to avoid electric shock.

MISE EN GARDE: Risque de décharge électrique.

Débrancher l'alimentation avant de réaliser tout raccordement électrique afin d'éviter tout risque de décharge électrique.



CAUTION: Risk of Property Damage.

Do not apply power to the system before checking all wiring connections. Short circuited or improperly connected wires may result in permanent damage to the equipment.

MISE EN GARDE: Risque de dégâts matériels.

Ne pas mettre le système sous tension avant d'avoir vérifié tous les raccords de câblage. Des fils formant un court-circuit ou connectés de façon incorrecte risquent d'endommager irrémédiablement l'équipement.

Install all wiring to conform to the National Electrical Code and local regulations. For maximum electrical rating of control, refer to the label inside the control cover. Use only copper conductors.

Consult Figures 4 and 6 for proper wiring and terminal designations.

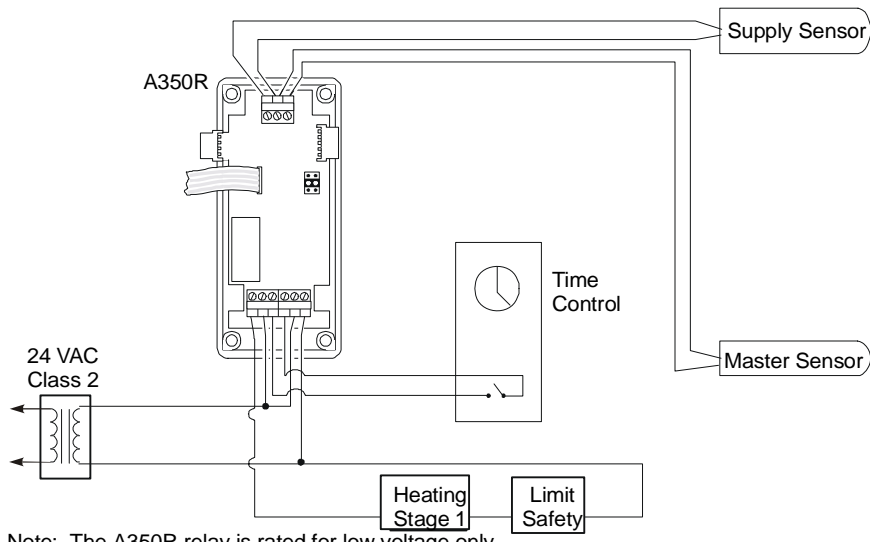

Note: The A350R relay is rated for low voltage only.
See *Specifications* table.

Figure 6: Typical Wiring Diagram of A350R Powered by an External Transformer

Sensor Connections

The A350R uses two sensors, which are included:

- The master sensor is the A99BC-25.
- The supply sensor is the A99BC-300.

(Refer to Table 3 for further information about these sensors.)

- Also included is assembly BOX10A-600R, a PVC enclosure that includes two wire nuts, a high-temperature cable tie, and a conduit connector.

The master and supply sensors must be connected to the 3-position terminal block located at the top of the base-mounted circuit board. (Refer to Figures 4 and 6.) The supply sensor connects to the S.S. and COM terminals. The master sensor connects to the COM and M.S. terminals. The sensors are not polarity sensitive.

Installing Master Sensor (Outdoor or Return Air)

Locate the sensor where it is not exposed to direct sunlight, preferably on the north side of the building. Mount the PVC enclosure so moisture cannot enter through the conduit connection. Block the conduit hole (with foam packing or similar material) to prevent air movement through the conduit opening, which could cause false readings of the master sensor. If required, a metal sun shield (SHL10A-603) is available.

The master sensor must be mounted so that it can accurately sense the outdoor or return air temperature driving the reset strategy.

Supply Sensor Installation

The supply sensor must be mounted so that it can accurately sense the temperature of the controlled medium.

For boiler applications, the preferred method is to install an immersion well assembly (WEL11A-601R or equivalent). If use of an immersion well is not possible and the temperature does not exceed 221°F (105°C), the sensor can be secured to a hot water pipe with the high temperature cable tie provided. Insulate the pipe and sensor.

Shielded cable is not generally required for sensor wiring on runs of less than 50 feet. When using shielded cable, isolate and tape the shield at the sensor. Connect the shield to the COM terminal on the A350R.

Refer to Table 2 for the maximum recommended cable lengths for particular sizes of wire.

Note: At the maximum cable lengths listed in Table 2, no more than 1F° (0.6C°) error in the sensed temperature will result due to wire resistance.

Table 2: Maximum Recommended Sensor Cable Lengths

Wire Gauge	Shielded Cable Length	
	Feet	Meters
14 AWG	800	244
16 AWG	500	152
18 AWG	310	94
20 AWG	200	61
22 AWG	124	38

* Values provided are for 2-wire stranded cable.

- Various A99B Series Temperature Sensors and mounting hardware are available for use with A350 Series Controls. Refer to Tables 3 and 5 for further information. The sensors must be connected to the appropriate terminals on the terminal strip located at the top of the printed circuit board. (See Figures 4 and 6.) The sensors are not polarity sensitive.

Table 3: A350R Controls And Sensors

Controls	Description of Sensors
A350RS-1C and A350RS-2C	Master: A99BC-25C; Range: -40 to 248°F (-40 to 120°C); Length: 9-3/4 in. (0.25 m) Supply: A99BC-300C; Range: -40 to 248°F (-40 to 120°C); Length: 9-3/4 ft (3 m)
A350RT-1C	No Sensor Included

- For more information regarding sensor options and installation, refer to the *A99B Series Temperature Sensors Product/Technical Bulletin (LIT-125186)*.

Adjustments

Follow this procedure to set up the A350R for desired operation.

1. Remove A350R cover by loosening the four captive cover screws. Refer to Figure 4.

Note: The cover is permanently attached to the base by a ribbon cable. Remove cover carefully to avoid breaking the ribbon cable or its connections.

2. Adjust the differential potentiometer DIFF to the desired setting. A Clockwise (CW) rotation increases the differential.
3. Select the desired warm weather shutdown temperature: 60°, 64°, 68°, 72°F, or OFF (OFF, 16°, 18°, 20°, 22°C). OFF is the factory setting. See Figure 2 for proper positioning of the jumper block.
4. Set the minimum supply temperature potentiometer (MIN SUPPLY) to the manufacturer's recommendations.
5. Adjust the master reset setpoint potentiometer (M.R.S.) to the desired setting. A clockwise rotation increases the setpoint.
6. Set the maximum supply temperature potentiometer MAX SUPPLY to the manufacturer's recommendations.
7. Determine the proper reset ratio for the application by using the following formula:

$$\text{Reset Ratio (master : supply)} = (K - T_D):(T_S - T_M)$$

Where:

- K = Master Reset Setpoint (M.R.S.)
- T_D = Design temperature of building
- T_S = Supply temperature of building
- T_M = Minimum supply temperature

Example:

M.R.S. = 70°F
Design temperature = 20°F
Maximum supply temperature = 200°F
Minimum supply temperature = 100°F
Reset ratio = 70 - (20):200 - 100
50:100
1:2

(Refer to Figure 2 for an illustration.)

8. Set the reset ratio on the control.
9. Select the desired Minimum Relay ON Time.
10. If setback is required, adjust the SETBACK potentiometer for the desired amount of setback and make sure the external time control is connected to the A350R.
11. Reinstall the cover and secure in place with the four captive cover screws.
12. Set the reset ratio adjustment to the desired ratio as determined in Step 7.

Checkout Procedure

Follow this procedure to verify the A350R is connected and functioning properly.

1. Before applying power, ensure that installation and wiring connections comply with job specifications.
2. After making adjustments and electrical connections, put the system into operation and observe at least three complete operating cycles before leaving the installation.

Troubleshooting

If the control system does not function properly, use the following procedures to determine the cause of the problem:

1. Check for proper voltages on the A350R Control.
 - a. Connect a Digital Voltmeter (DVM) between the 24 VAC (+) and COM (-) terminals located at the bottom right side of the A350R (refer to Figure 4).
 - If an external transformer is used, select AC volts on the DVM and verify that the voltage is between 20 and 30 VAC.
 - If a Y350R Power Module is used, select DC volts on the DVM and verify that the voltage is between 16 and 38 VDC.
 - If an external DC power supply is used, select DC volts on the DVM and verify that the voltage is between 22 and 29 VDC.
2. Check temperature sensors for proper resistance.
 - a. Remove power and disconnect both sensors from the A350R.
 - b. Take accurate, independent temperature readings at the sensor locations.
 - c. Using an ohmmeter, measure the resistance across the two leads of each sensor.
 - d. Refer to Figure 7 to determine the optimal resistance for the measured temperature.
 - e. If the measured resistance varies substantially from the optimal resistance for that temperature, the sensor or wiring must be replaced.
 - f. If the sensor's resistance conforms to the chart in Figure 7, reconnect the sensor to the control.
 - g. Reconnect power to the control.

Note: The sensor readings indicated by the D350 may differ from thermometer readings due to sensor tolerances, time constants, thermometer accuracy, and other factors.

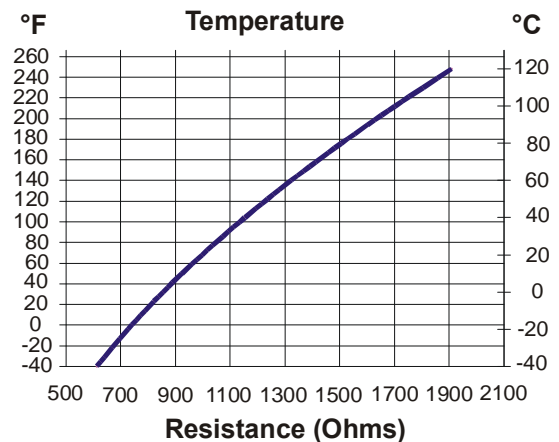

Figure 7: Temperature vs. Resistance Chart for the A99B Series Sensor

3. Check the A350R for proper operation.

Note: Perform Steps 1 and 2 first.

- a. Reconnect the sensors to the A350R and re-apply power.
- b. Verify the MIN SUPPLY adjustment is not too high and that the MAX SUPPLY adjustment is not too low. Either condition could limit the active range of the supply setpoint to just a few degrees.
- c. Disconnect the load from the A350R's relay output terminals.
- d. Using an ohmmeter, measure the relay contact resistance with the relay On and with it Off by using one of the following procedures.
 - If the relay is On, measure contact resistance, then disconnect power and the supply sensor wire from the A350R. Wait at least five seconds and then re-apply power. The relay should stay Off. Measure Off contact resistance.
 - If the relay is Off, measure contact resistance, then short the SUPPLY SENSOR terminal to the COM terminal. The relay should come On. Measure On contact resistance.
- e. If the relay cannot be switched On and Off as described in Step 3d, replace the A350R.
- f. If the On contact resistance is 1 ohm or less and the Off contact resistance is greater than 1000 megohms, proceed to Step 4. Otherwise, replace the A350R.

Repairs and Replacement

4. Check the remaining load wiring.
 - a. Rewire if necessary. If the load device is faulty, replace it.
 - b. If you determine that the load is functioning properly, replace the A350R.

Do not make field repairs or perform calibration. A99B Temperature Sensors and replacement controls are available through local Johnson Controls representatives.

Table 4: System 350 Products

Item	Product Code Number	Description
A350R Temperature Reset Control	A350RS-1C	Dual scale Packaged with A99BB-300C and A99BC-25C sensors
Display Modules	D350AA-1C D350BA-1C	Fahrenheit scale Celsius scale
On/Off Stage Modules	S350AA-1C S350AB-1C	Fahrenheit Scale Celsius Scale
Slave Stage Module	S350CC-1C	Dual Scale (°F and °C)
Proportional Stage Module	S350PQ-1C	Dual Scale (°F and °C)
Time Control	CLK350-1	External clock for enabling setback
Power Module	Y350R-1C	120 or 240 VAC, 50/60 Hz input; rectified 24V Class 2 output

Table 5: System 350 Accessories

Item	Product Code Number	Description
Enclosure	BOX10A-600R	PVC enclosure; includes wire nuts and conduit connector
Immersion Well	WEL11A-601R	For liquid sensing applications
Mounting Clip	A99-CLP-1	Surface mounting clip for the A99B Temperature Sensor
Conduit Adaptor	ADP11A-600R	1/2 in. snap-fit EMT conduit adaptor (box of 10)
Duct Mounting	TE-6001-1	Duct-mounting hardware with handy box
Duct Mounting	TE-6001-11	Duct-mounting hardware without handy box
Sun Shield	SHL10A-603R	For use with outside sensors in sunny locations
DIN Rail Sections	BKT287-1R BKT287-2R	12 in. (0.3 m) long 39-1/3 in. (1.0 m) long
DIN Rail End Clamp	PLT344-1R	Consists of two end clamps
Cables for Remote Mounting of D350 Display Module	WHA29A-600R* WHA29A-603R WHA29A-604R	3 ft (0.9 m) 25 ft (7.6 m) 50 ft (15.2 m)

*WHA29A-600R can also be used to daisy chain S350 Stage Modules together.

Specifications

Product	A350R Electronic Temperature Reset Control		
Supply Voltage	Y350R Power Module:	Input:	120/240 VAC 50/60 Hz
		Output:	24 VDC, unfiltered, 10 VA, Class 2
	External Source:	24 VAC, 50/60 Hz Class 2 (20-30 VAC)	
	Note:	Only one supply voltage source may be used.	
Power Consumption	3.2 VA Maximum		
Ambient Temperature	Operating:	-4 to 150°F (-20 to 66°C)	
	Shipping:	-40 to 185°F (-40 to 85°C)	
Humidity	0 to 95% RH Non-condensing, 85°F (29°C) Maximum Dew Point		
Reset Ratio Adjustment Range	1:5 to 3:1 (Master:Supply)		
Reset Action	Reverse Acting		
Master Reset Setpoint Adjustment Range	40 to 70°F (4 to 21°C)		
Minimum Supply Temperature Adjustment Range	50 to 160°F (10 to 71°C)		
Maximum Supply Temperature Adjustment Range	160 to 220°F (71 to 104°C)		
Differential Adjustment Range	1 to 30°F° (0.5 to 17°C°)		
Relay On-Time	Jumper Selectable:	OFF, 1 min., 2 min., or 3 min.	
Warm Weather Shutdown	Jumper Selectable:	OFF, 60, 64, 68, or 72°F (OFF, 16, 18, 20, or 22°C)	
Setback Adjustment Range	0 to 30°F° (0 to 17°C°) Enabled by an External Time Clock with Contacts Rated for 5 mA @ 5 VDC		
Mode of Operation	Heating (Differential is below the setpoint.)		
Relay Contact	SPST	Maximum:	4A non-inductive, 24 VAC; Pilot Duty 42.4 VA at 24 VAC
		Minimum:	100 mA at 5 VDC
Material	Case, Cover: NEMA 1 High-impact Thermoplastic		
Agency Listing	UL Listed, CCN XAPX, File E27734 UL Listed for Canada, CCN XAPX7, File E27734		

The performance specifications are nominal and conform to acceptable industry standards. For application at conditions beyond these specifications, consult Johnson Controls Application Engineering at (414) 524-5535. Johnson Controls, Inc. shall not be liable for damages resulting from misapplication or misuse of its products.



Building Efficiency
507 E. Michigan Street, Milwaukee, WI 53202

® Johnson Controls and PENN are registered trademarks of Johnson Controls, Inc. in the United States of America and/or other countries. All other trademarks used herein are the property of their respective owners. © Copyright 2014 by Johnson Controls, Inc. All rights reserved.