



H15 Series BASO® Automatic Shutoff Pilot Gas Valve

The H15 Series pilot valves provide safe lighting and complete shutoff of pilot and main burner gas in the event that the flame heating the thermocouple is extinguished. They are designed for standing pilot applications and can be used with natural gas and Liquefied Petroleum (LP) gas, at pressures up to 0.5 psi (35 mbar [3.5 kPa]). Typical applications include commercial cooking equipment, heaters, kilns, dishwashing equipment, industrial ovens, and similar applications.

In addition to U.S. and Canadian certifications, the H15 models without a rotor B valve are CE Certified.



Figure 1: H15 Automatic Pilot Valve

Features and Benefits	
Compact Design	Permits installation in dimensionally restricted applications
Safe Lighting	Allows gas flow only to the pilot burner during lighting
Reliable	Proven by thousands of units in service
Easy Operation	Provides simple lighting with use of large reset button
Approved Worldwide (Models without Rotor B Valve Only)	Broadens applications to include global markets

Application

The H15 series automatic pilot valves provide safe lighting and complete shutoff of pilot and main burner gas. They are designed for standing pilot applications and can be used with natural gas, LP gas, or LP gas-air mixtures at pressures up to 0.5 psi (35 mbar [3.5 kPa]). Models without a rotor B valve are suitable for operation over a temperature range of

-30 to 175°F (-34 to 79°C). Models with a rotor B valve are suitable for operation over a temperature range of 32 to 175°F (0 to 79°C). The H15_B and H15_R models are suitable for operation over a temperature range of 32 to 300°F (0 to 149°C).

The use of single function components provides maximum flexibility in manifold makeup. By combining the H15 pilot valve with other single function components (pressure regulator, automatic gas valve, and manual valve), you can meet the exact requirements of a wide variety of applications.

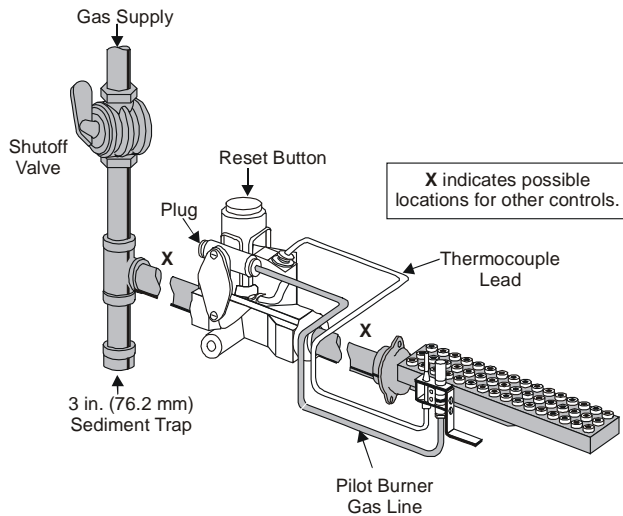

Figure 2: Internal Pilot Gas Flow Installation

Description

H15 valves are 100% shutoff devices with compact, cast aluminum valve bodies. A rotor B valve is provided as an option for manual adjustment of the pilot flame (Figure 3). The flow interruption feature allows gas to flow only to the pilot during the lighting operation.

Mounting

You may mount the H15 valves in any convenient position.

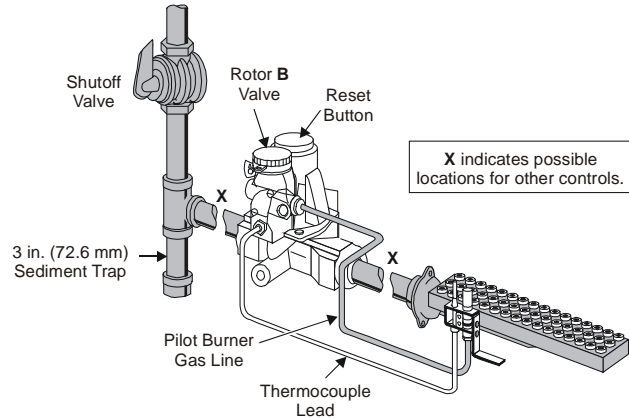

Figure 3: Internal Pilot Gas Flow and Rotor "B" Valve Installation

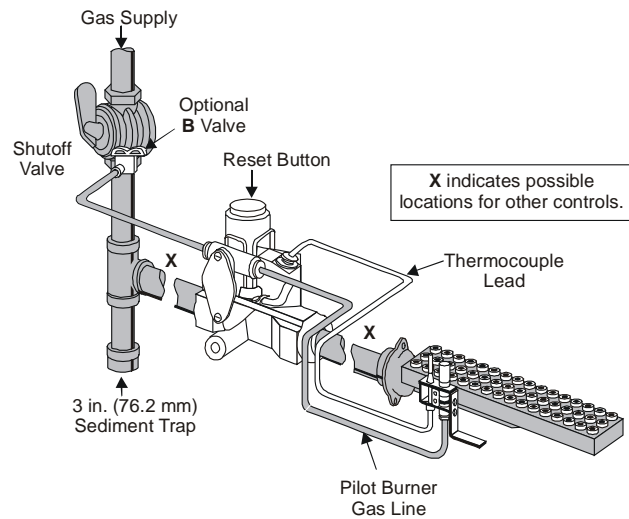

Figure 4: External Pilot Gas Flow Installation

Dimensions

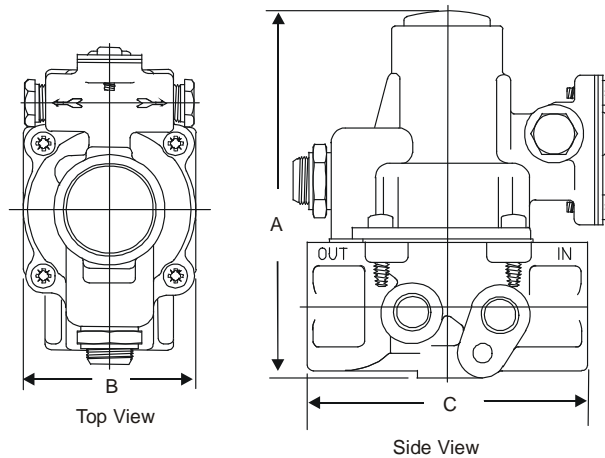

Figure 5: Internal Pilot Gas Valve Dimensions

Table 1: Internal Pilot Gas Valve Dimensions

Product Number	A Maximum Length		B Maximum Width		C Maximum Height	
	in.	mm	in.	mm	in.	mm
H15AA	2.95	75	2.22	56.4	3.50	89
H15AB	2.95	75	2.22	56.4	3.50	89
H15CA	3.17	80.5	2.25	57	3.93	100
H15CB	3.17	80.5	2.25	57	3.93	100
H15DA	3.17	80.5	2.25	57	3.93	100
H15DB	3.17	80.5	2.25	57	3.93	100
H15FA	3.50	89	2.69	68	4.65	118
H15QB	2.53	64	2.56	65	3.53	90

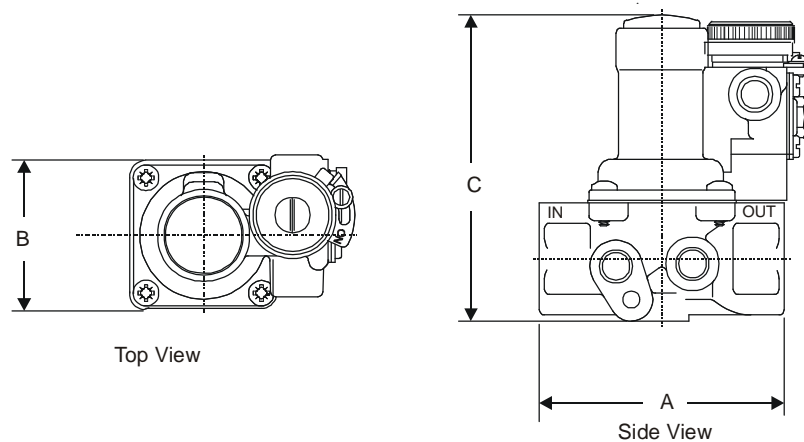

Figure 6: Internal Pilot Gas Valve with Rotor B Valve Dimensions

Table 2: Internal Pilot Gas Valve with Rotor B Valve Dimensions

Product Number	A Maximum Length		B Maximum Width		C Maximum Height	
	in.	mm	in.	mm	in.	mm
H15CH	3.36	85.2	1.84	47	3.76	95.5
H15DH	3.36	85.2	1.84	47	3.76	95.5

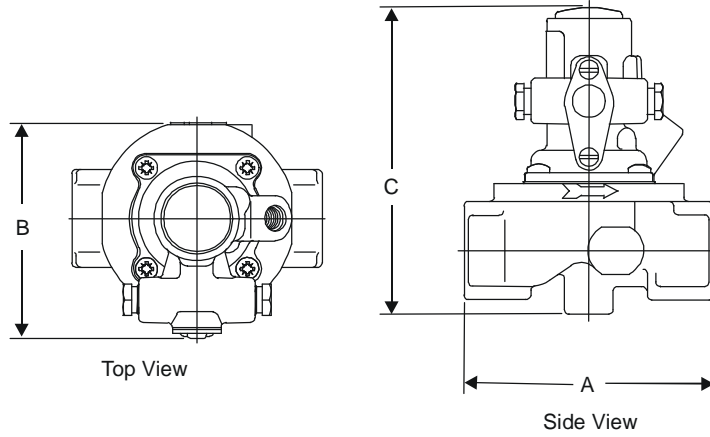
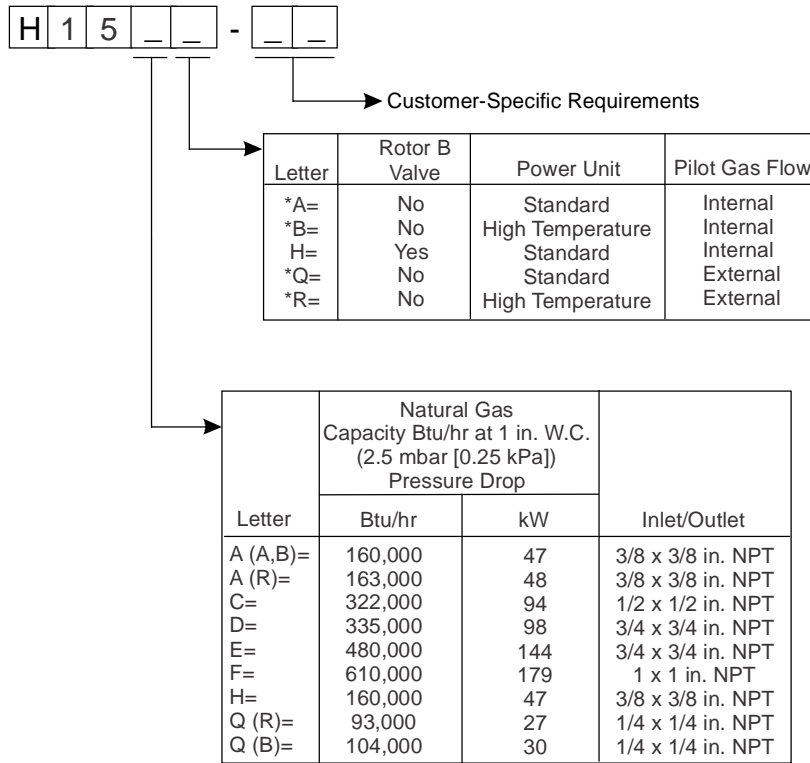

Figure 7: External Pilot Gas Valve Dimensions

Table 3: External Pilot Gas Valve Dimensions

Product Number	A Maximum Length		B Maximum Width		C Maximum Height	
	in.	mm	in.	mm	in.	mm
H15AR	2.95	75	2.25	57	3.550	89
H15CQ	3.00	76	2.59	66	3.93	100
H15DQ	3.00	76	2.59	66	3.93	100
H15EQ	3.50	89	3.00	76	4.30	109.3
H15FQ	3.50	89	2.69	68	4.65	118
H15HQ	2.53	64	2.56	65	3.53	90
H15HR	2.53	64	2.56	65	3.53	90
H15QR	2.53	64	2.56	65	3.53	90

Ordering Information



*Indicates CE Certified.

The presence of a particular construction in this information does not guarantee its availability. Consult BASO Gas Products for available constructions.

Figure 8: Ordering Matrix

Technical Specifications

Product	H15 Series BASO Automatic Shutoff Pilot Gas Valve
Rated Inlet Pressure	0.5 psi (35 mbar [3.5 kPa])
Valve Body	Aluminum
Recommended Thermocouple Lead Lengths	K15: 12 to 48 in. (305 to 1,220 mm) K16: 12 to 72 in. (305 to 1,830 mm) K19: 18 to 72 in. (457 to 1,830 mm)
Permissible Ambient (Surface) Temperature	-30 to 175°F (-34 to 79°C) models without rotor B valve 32 to 175°F (0 to 79°C) models with rotor B valve 32 to 300°F (0 to 149°C) H15_B and H15_R models only
Inlet and Outlet Body Connections	1/4, 3/8, 1/2, 3/4, or 1 in. NPT
Valve Torsion Group	Group 2 (EN 125)
Gas Valve Classification	Class B (EN 125)
Types of Gas	Natural, Liquefied Petroleum (LP), and LP gas-air mixtures
Packaging	Bulk pack supplied to original equipment manufacturer (individual pack optional)
Bulk Pack Quantity	20, 30, 32, and 40 (depending on valve size)
Bulk Pack Weight	24 to 42 lb (11 to 19 kg)
Agency Listing	CSA Certificate Number 229521-1656080 Australian Gas Association Certificate Number 4236 (Specific models without rotor valve only) AGA Class 1, Valve Type Flame Safeguard (excludes H15Q_ and H15_B) EC Type Examination Certificate Number C86CS02 (excludes models with rotor B valve, H15E_, and H15Q_) UL File Number MH2926 (H15CA, CH, and DA models only)
Specification Standards	ANSI Z21.20, CAN1-6.4 ANSI Z21.21, CSA 6.5 ANSI Z21.78, CSA 6.20 AS 4620 EN 125 UL Standard 372

Performance specifications are nominal and conform to acceptable industry standards. All agency certification of BASO products is performed under dry and controlled indoor environmental conditions. Use of BASO products beyond these conditions is not recommended and may void the warranty. Product must be protected if exposed to water (dripping, spraying, rain, etc.) or other harsh environments. The original equipment manufacturer or end user is responsible for the correct application of BASO products. Consult BASO Gas Products LLC for questionable applications. BASO Gas Products LLC shall not be liable for damages or product malfunctions resulting from misapplication or misuse of its products.

Refer to the *H15 Series BASO Automatic Shutoff Pilot Gas Valve Installation Instructions (Part No. BASO-INS-H15)* for necessary information on the installation, use, and servicing of this product.



BASO Gas Products LLC

450 East Horseshoe Road
PO Box 170
Watertown, WI 53094
1-877-227-6427 (1-877-BASOGAS)

www.baso.com
Published in U.S.A.